



User Manual

**WolfPack 4K 60 Hz AV Over IP Encoder with
Video Wall Processing**

HDTVPIPE5100





Important Safety Instructions



1. Do not expose this apparatus to rain, moisture, dripping or splashing and that no objects filled with liquids, such as vases, shall be placed on the apparatus.



6. Clean this apparatus only with dry cloth.



2. Do not install or place this unit in a bookcase, built-in cabinet or in another confined space. Ensure the unit is well ventilated.



7. Unplug this apparatus during lightning storms or when unused for long periods of time.



3. To prevent risk of electric shock or fire hazard due to overheating, do not obstruct the unit's ventilation openings with newspapers, tablecloths, curtains, and similar items.



8. Protect the power cord from being walked on or pinched particularly at plugs.



4. Do not install near any heat sources such as radiators, heat registers, stoves, or other apparatus (including amplifiers) that produce heat.



9. Only use attachments / accessories specified by the manufacturer.



5. Do not place sources of naked flames, such as lighted candles, on the unit.



10. Refer all servicing to qualified service personnel.



Table of Contents

Introduction	5
Overview	5
Features	5
Package Contents	8
Encoder	8
Specifications	9
Encoder	9
Panel Description	12
Encoder	12
Bracket Installation	16
Typical Applications	17
Scenario 1	17
Scenario 2	18
Hardware Installation	19
Operating the Devices	20
Introduction to Different Operation Tools	20
Performing Fast Switching	21
Before You Start	21
Configuring Mouse Roaming	24
Configuring before HDR10/Dolby Vision Signal Input	26
Dante Audio System Configurations	27
An Overview of Dante	27
Before You Start	28
Dante Audio System Applications	28
Application 1: Configuring Encoder to Transmit Dante Audio	28
Application 2: Configuring Decoder to Receive Dante Audio	30
Application 3: Configuring Encoder to Bridge Dante Audio to Native	



Application 1: Configuring Encoder to Transmit Dante Audio	28
Application 2: Configuring Decoder to Receive Dante Audio.....	30
Application 3: Configuring Encoder to Bridge Dante Audio to Native Network	31
Application 4: Configuring Decoder to Bridge Native Audio to Dante Network	32
Firmware Upgrade	33



Introduction

Overview

IP5100 series encoders and decoders provide the flexible, powerful, and scalable solution at resolutions up to 3840 x 2160@60Hz 4:4:4. They allow 4K UHD media to be switched and distributed over standard gigabit Ethernet networks, providing complete end-to-end streaming systems. Audio, video together with IR, and USB signals can be routed separately or as a whole throughout the matrix system. Both of them have the capacity to handle and output up to 7.1 channel audio, allowing you to enjoy the finest sound. Equipped with Dante technology, they realize perfect interconnectivity and interoperability with Dante audio systems.

HDCP 2.2/2.3 specifications are employed. A local area network is covered with a range up to 330ft (100m) over a single Cat 5e cable or above. Standard features like, bi-directional serial, bi-directional IR, and independent analog audio input/output are included. The codecs allow roaming/USB extension to take place to control a keyboard and a mouse. Flexible control options are offered – Windows PC configurator (HDMIoverIPConsole), VisualM on iPad and IP controller (SC009). They are the perfect solution for any low latency and signal routing applications. Common applications include homes, classrooms, conference rooms and broadcasts.

Features

- Selects between either the 1G Optical port or 1G BASE-T port automatically for stable IP stream transmission.
- Distributes and switches 4K UHD AV signals via standard gigabit Ethernet networks, providing complete end-to-end streaming systems.
- Supports HDMI input and output resolutions up to 3840 x 2160@60Hz 4:4:4.



- Supports streaming resolutions up to 3840 x 2160@60Hz 4:4:4.
- Features video wall up to the dimensions of 16 x 16.
- Supports HDR10 and Dolby Vision.
- Supports Dante audio.
- Supports CEC one-touch-play and standby commands to power on and off the display, as well as CEC Frame.
- Supports multi-channel audio up to PCM 7.1, Dolby Atmos, DTS HD Master and DTS:X.
- Analog audio embedding and de-embedding.
- S/PDIF audio return from decoder to encoder.
- HDMI ARC audio return (FW Will be ready for Q2E).
- HDCP 2.2/2.3 compliant.
- Flexible routing policies, allowing audio, video, USB, IR and RS232 signals to be routed separately or as a whole throughout the matrix system.
- Allows AV, USB, IR, RS232 and power signals to be delivered up to 328ft/100m over a single Cat 5e cable or above.
- 1 frame latency.
- Supports bi-directional serial communication, allowing control of remote RS232 devices between encoders/decoders and IP controller (SC009), or between encoders and decoders.
- Supports bi-directional IR pass-through, allowing control of remote source and display devices between encoders and decoders.
- Supports IR generation – send IR codes through API.
- USB Device ports for KM over IP seamless switching and roaming.
- Supports point-to-point, point-to-multipoint, multipoint-to-point, multipoint-to-multipoint applications.
- Supports PoE to be remotely powered by compatible power source equipment such as a PoE-enabled Ethernet switch, eliminating the need for a nearby power outlet.
- Supports user-selectable output HDCP configuration via PC configurator or IP Controller (SC009).



- Fit in/stretch out video wall, and rotate video management -- Decoded video can fill a video wall, maintain aspect ratio in a video wall, or can be rotated 180 ° and 270 ° clockwise, presenting imagery that meets customer expectations.
- Supports DHCP by default, and will fall back to AutoIP if there's no DHCP server in the system.
- Flexible control options -- VisualM app on iPad and IP controller (SC009).
- Supports communications protocols of Telnet, SSH, HTTP, HTTPS.



Package Contents

Encoder

- 1 x Encoder
- 1 x DC 12V Power Adapter with US Pins
- 1 x 3.5mm 3-Pin Phoenix Male Connector
- 1 x IR Emitter (1.2m)
- 1 x Broadband IR Receiver (1m, 30 kHz ~ 50 kHz)
- 4 x Mounting Brackets (with 4 x M3*L5 Screws)



Specifications

Encoder

Video	
Input Video Port	1 x female HDMI type A (19 pins)
Input Video Type	HDMI 2.0, HDCP 2.2/2.3
Input Resolutions	3840 x 2160p@24Hz 4:4:4, 3840 x 2160p@30Hz 4:4:4, 3840 x 2160p@50Hz 4:4:4, 3840 x 2160p@60Hz 4:4:4, 640 x 480p@60Hz, 720 x 480p@60Hz 1280 x 720p@60Hz, 1920 x 1080i@60Hz, 1920 x 1080p@60Hz, 720 x 576p@50Hz 1280 x 720p@50Hz, 1920 x 1080i@50Hz 1920 x 1080p@50Hz, 1920 x 1080p@24Hz 1920 x 1080p@25Hz, 640 x 480@60Hz, 800 x 600@60Hz 1024 x 768@60Hz, 1280 x 720@60Hz 1280 x 768@60Hz, 1280 x 800@60Hz 1280 x 960@60Hz, 1280 x 1024@60Hz 1366 x 768@60Hz, 1366 x 768@60Hz 1400 x 1050@60Hz, 1440 x 900@60Hz 1600 x 900@60Hz, 1600 x 1200@60Hz 1680 x 1050@60Hz, 1920 x 1080@60Hz 1920 x 1200@60Hz
Output Video Port	1 x female RJ-45, 1 x Optical
Output Video Type	IP Stream
Output Resolutions	Up to 3840 x 2160p@60Hz 4:4:4
Average Encoding Data Rate	3840 x 2160@60Hz: 650Mbps (avg) / 900Mbps (max)
End-to-End Time Latency	1 frame
Input/Output Video Signal	0.5~1.2 V p-p
Input/Output DDC Signal	5 V p-p (TTL)
Video Impedance	100 Ω
Maximum Data Rate	18 Gbps (6 Gbps per color)
Maximum Pixel Clock	600 MHz
Audio	
Input Audio Port	1 x HDMI; 1 x 3.5 mm stereo jack
Input Audio Type	<ul style="list-style-type: none">HDMI: Fully supports audio formats in HDMI 2.0 specification, including PCM 2.0/5.1/7.1, Dolby TrueHD, Dolby Atmos, DTS-HD Master Audio and



Audio	
	DTS:X; <ul style="list-style-type: none">• Audio In: analog
Output Audio Port	1 x 3.5 mm stereo jack; 1 x S/PDIF Out; 1 x LAN/Optical
Output Audio Type	<ul style="list-style-type: none">• Audio Out: analog• S/PDIF Out: digital audio• LAN/Optical: Fully supports audio formats in HDMI 2.0 specification, including PCM 2.0/5.1/7.1, Dolby TrueHD, Dolby Atmos, DTS-HD Master Audio and DTS:X
Dante Audio Type	LPCM 2.0, 44.1/48/88.2/96 KHz

Control	
Control Method	Windows PC configurator (HDMIoverIPConsole), VisualM on iPad, IP controller (SC009)

General	
Operating Temperature/ Humidity	+32°F ~ +113°F (0°C ~ +45°C) 10% ~ 90%, non-condensing
Storage Temperature/ Humidity	-4°F ~ +158°F (-20°C ~ +70°C) 10% ~ 90%, non-condensing
Power	12 VDC 2 A; PoE
Power Consumption	7W (Max)
ESD Protection	Human body model: <ul style="list-style-type: none">• ±8 kV (air-gap discharge)• ±4 kV (contact discharge)
Dimensions (W x H x D)	8.46" x 0.98" x 4.72" (215 mm x 25 mm x 120 mm)
Net Weight	1.63 lbs (0.74 kg)



Panel Description

Encoder

Front Panel



No.	Name	Description	
1	POWER LED	On	The device is powered on.
		Blinking	The device is booting.
		Off	The device is powered off.
2	STATUS LED	Solid On	The device is connected to an active video source.
		Blinking	The device is not connected to an active video source.
		Off	<ul style="list-style-type: none">The device is powered off.The device is booting.Network is down.

Rear Panel





No.	Name	Description
1	12V	Connect this port to the 12 V 2 A power adapter.
2	RESET	When the device is powered on, use a pointed stylus to hold down the RESET button for five or more seconds, and then release it, it will reboot and restore to its factory defaults. Note: When the settings are restored, your custom data is lost. Therefore, exercise caution when using the RESET button.
3	LAN (POE)	Connect either the LAN (POE) port or Optical port to a gigabit Ethernet switch for IP stream output and device control (the device can be powered by a PoE-enabled switch through LAN (POE) port). Default IP Mode: DHCP
4	OPTICAL	Note: 1) Connect the Optical port to the Ethernet switch using a single-mode or multi-mode SFP module (not included in package). The transmission distance may vary depending on the specific SFP module used. 2) DO NOT connect both the LAN (POE) port and Optical port to the Ethernet switch simultaneously, or device exceptions may occur.
5	HDMI IN	Connect this port to an HDMI source device.
6	AUDIO IN	Connect this 3.5 mm stereo tip-ring-sleeve port to an audio source such as a computer for unbalanced stereo audio input.
7	AUDIO OUT	Connect this 3.5 mm stereo tip-ring-sleeve port to an audio receiver for unbalanced stereo audio output.
8	S/PDIF OUT	Connect this optical S/PDIF connector for digital audio output.
9	USB Host	Connect a type A male to type B male USB cable between this port and the USB port of a computer for transmitting USB 2.0 data, or for KMolP seamless switching and roaming.
10	RS-232	RS232 serial port for bidirectional serial communication.
11	IR IN	Connect this port to an IR receiver for IR communication with an IR emitter at the decoder side on the network.
12	IR OUT	Connect this port to an IR emitter for IR communication with an IR receiver at the decoder side on the network.



Bracket Installation

Note: Before installation, ensure all devices are disconnected from the power source.

Steps to install the device on a suitable location:

1. Attach the mounting brackets to the panels of both sides using the screws (two on each side) provided in the package.

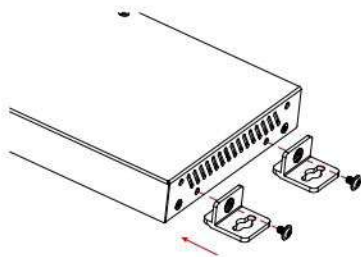

2. Install the brackets onto the position as desired using the screws (not included).

Note: The installation of encoders and decoders is similar.

Typical Applications

Scenario 1

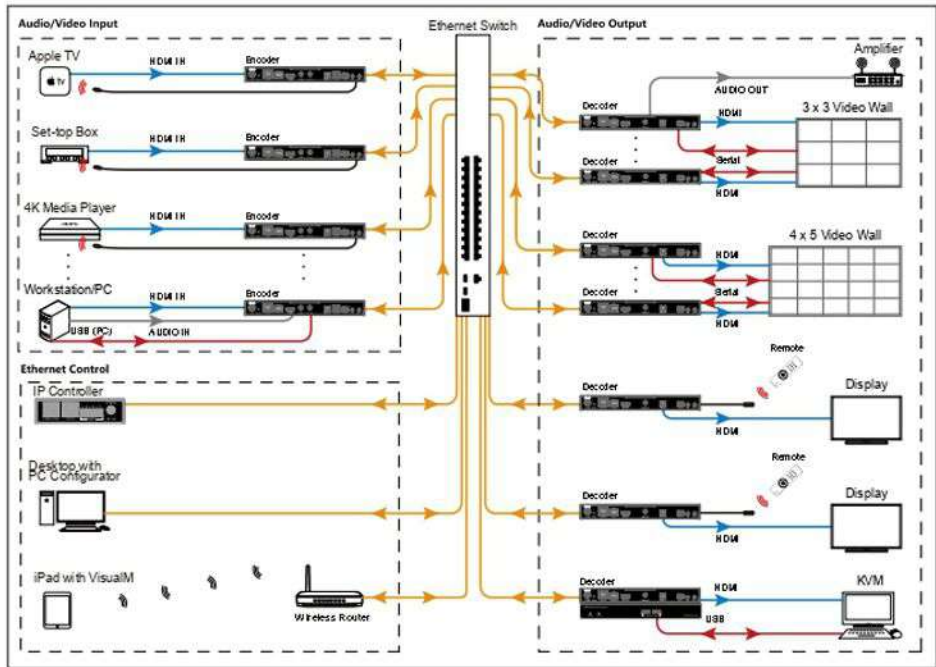

Scenario 2

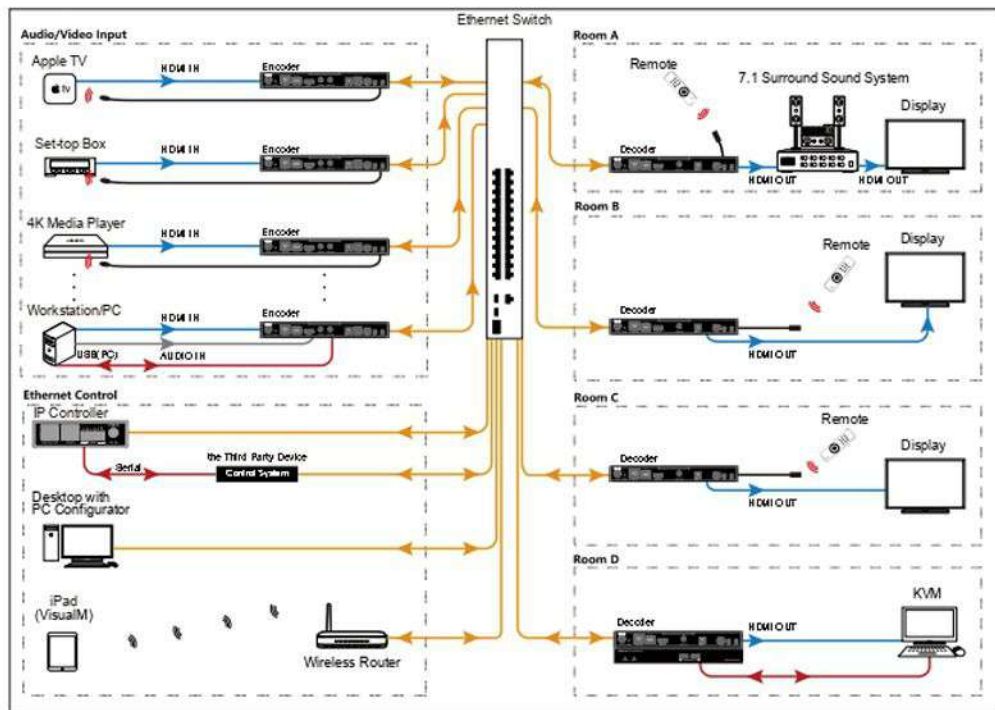

Hardware Installation

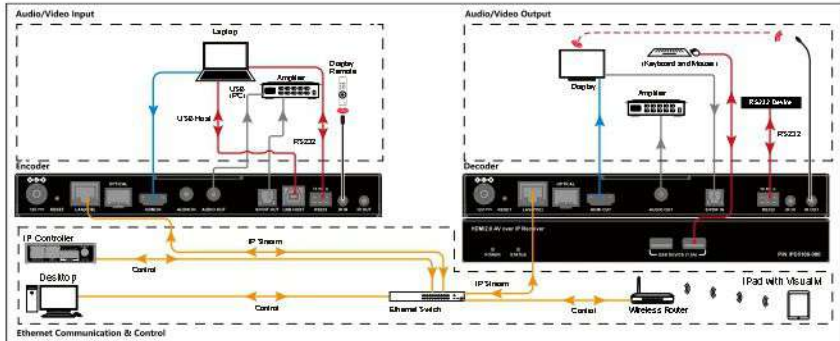

Note:

If the Ethernet switch doesn't support PoE, connect encoders and decoders to their power adapters.



Operating the Devices

Introduction to Different Operation Tools

The IP5100 series products allow you to use PC configurator, VisualM and IP controller (SC009) to manage and control them. This section briefly introduces how to route the video from source to the display using these tools. By default, audio, video together with IR, and USB signals are routed as a whole. For more information, see their guides.

The following tables describes how audio, video together with IR, and USB signals are routed using all the different tools.

Operation Tools	Description
PC Configurator	Route audio, video together with IR and USB signals as a whole.
VisualM	
IP Controller	Both of the following routing policies are available. <ul style="list-style-type: none">• Route audio, video together with IR and USB signals as a whole.• Route audio, video together with IR, and USB signals separately via IP controller's API commands.

Note:

When audio, video together with IR, and USB signals are routed separately via IP controller's API commands, they can be routed as a whole using other operation tools.



Performing Fast Switching

The fast video switching function is that when a source change is implemented the switch occurs very quickly and appears seamless to the human eye with the latency of one second only. However, users shall meet several requirements prior to realize fast switching, otherwise video switching may take longer (approx. 5~7 seconds), and black out screen would arise.

Before You Start

Complete the following requirements before performing fast video switching:

1. Verify you have the firmware version of 1.3.x or higher for the decoders and all of which use the same version.
2. Verify that the latest video source to be input **MUST** has the same video timing as current video source, including:
 - a. Same resolution and refresh rate (e.g. all with 1080p@60Hz).
 - b. Switching from HDMI to DVI timing is also available. (DVI to HDMI will cause black screen issue.)
 - c. Same scanning mode (interlace/progressive).
 - d. Same HDMI info frame (e.g. switch between 2D and 2D, or 3D and 3D).
 - e. Same color space.
 - f. Same color depth.
 - g. Decoders that are set for forced scaler output are exempt from the requirement:
set astparam "v_output_timing_convert" as expected output. For more information, refer to the separate document "IP5X00 Console API".
3. Verify that the same HDCP mode is applied on all sources. Switching between HDCP and non-HDCP will cause black screen issue.
 - a. Decoders that are set for forced HDCP output are exempt from the requirement: set astparam 'hdcp_always_on' and



'hdcp_always_on_22' as expected output. For more information, refer to the separate document "IP5X00 Console API".

- Verify that all sources are with support of SDR instead of HDR; switching between SDR and HDR (including HDR10 / HDR10+ / Dolby Vision) will result in black screen.

e.g.

SDR → SDR: ✓ (fast switching)

SDR → HDR10 / HDR10+ / Dolby Vision: × (black screen occurs)

The following table lists different cases in which whether black screen encounters or not.

Change Case		Pass through	Force Timing (†)(#)	Force Timing (†) (w initial pixel format)	Pass through (Strict Mode)	Force HDCP	Force Timing (†)(#) & Force HDCP	
HDCP Change		•	•	•	•	○ (1)	○ (1)	
Resolution Change		•	○	○	•	•	○	
Refresh Rate Change (*1)		•	○	○	•	•	○	
DVI-to-HDMI		•	○	○	•	•	○	
Color Depth Change		•	○ (2)	○ (2)	•	○ (2)	○ (2)	
HDR Change	from/to HDR10 (*2)	•	•	•	•	•	•	
	from/to HDR10+ (*3)	•	•	•	•	•	•	
	from/to Dolby Vision (*3)	•	•	•	•	•	•	
AVI-IF Change	Extended Colorimetry (EC)	from/to BT.2020	•	○ (3)	•	•	○ (3)	
	Colorimetry	from/to EC	•	○ (3)	•	•	○ (3)	
	Pixel Encoding	both EC are BT.2020 (*4)	•	○ (3)	•	•	•	○ (3)
		from/to YUV420	•	○ (3)	•	•	•	○ (3)
		others	○	○	○	•	○	○
others		○	○	○	•	○	○	
VS-IF Change		○	○	○	○	○	○	
DRM-IF Change (*5)		○	○	○	○	○	○	



Change Case Configuration	Pass through	Force Timing (†)(#)	Force Timing (†) (w initial pixel format)	Pass through (Strict Mode)	Force HDCP	Force Timing (†)(#) & Force HDCP
Note						
Pixel Encoding: RGB/YUV444/YUV422/YUV420 Colorimetry: BT709/BT.601						
<ul style="list-style-type: none">● - Do re-configure whole Video Output, black screen occurs.○ - Do not re-configure whole Video Output, black screen doesn't occur.						
*1 - NTSC/non-NTSC case (i.e., 59.94/60Hz, 29.97/30Hz ...etc.) is not included.						
*2 - Need to re-configure whole Video Output to avoid incorrect brightness issue.						
*3 - Need to re-configure whole Video Output to avoid video sink (TV) compatibility issue.						
*4 - Need to re-configure whole Video Output to solve incorrect HDR display with specific player.						
*5 - YouTube HDR switching behavior, a few monitors always display black screen during video change even if that monitor directly connects to the video source.						
† - video output will keep in the specified video resolution and refresh rate defined in forced-timing configuration when whole Video Output is re-configured.						
# - default pixel encoding is RGB 8 bits. Can be configured to YUV444/YUV422 by setting <code>astparam, v_output_timing_convert</code> , BIT [29] and BIT [22:21]. Please refer to document "IP5X00 Console API" for details.						
(1) HDCP level stays in what user defined.						
(2) Keep the same color depth as what it was set on previous "whole Video Output configuration".						
(3) Users may see something a little bit different if compared to the output from original source.						

Configuring Mouse Roaming

IP5100 series products support Mouse Roaming. With configuration on PC Configurator, you can move the mouse to the edge of the screen to control different computers in a system. They support one set of mouse and keyboard to control up to 16 host computers.

Here takes the 2 x 1 video wall for example.

To configure Mouse Roaming, perform the following:

1. Connect one computer to the HDMI IN and USB Host ports of each TX; and one set of mouse and keyboard to the USB Device1 ports of one RX.

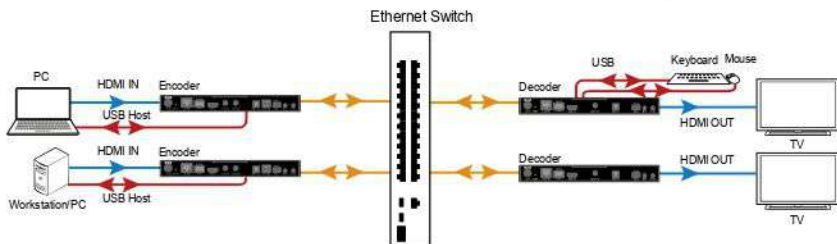

2. Launch the **HDMIOverIPConsole.exe** on your computer to open its main page. (Ensure your PC, TX and RX are on the same subnet.)
Click **Search** to search for online devices.

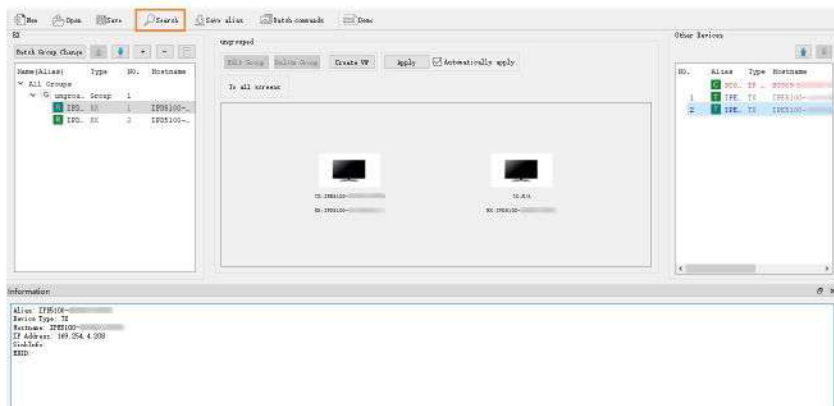

3. Create a video wall.

Click **ungrouped** in the RX list > **Create VW** > Name a video wall **VW** and specify rows and columns > **OK**.

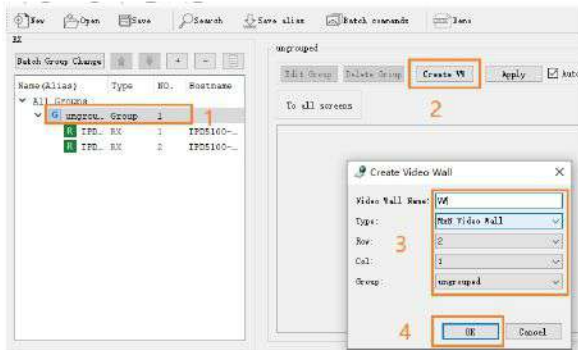

4. Create a layout for the video wall.

Click **VW** in the RX list > **Create Layout/Scene** in the working area > name this layout **layout1** and choose **Mouse Roaming** > **OK**.

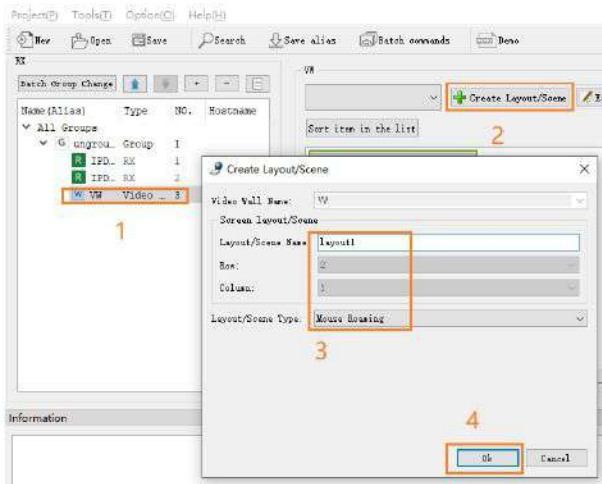

5. Configure RX and TX for layout 1.

Drag RXs from the RX list and TXs from Other Devices area to display tiles in the working area.

6. Configure Master and Slave.



Right click the RX to which the mouse and keyboard are connected and choose **Select Master** > right click the other RX and choose **Select Slave** > Click **Apply** > **OK**.

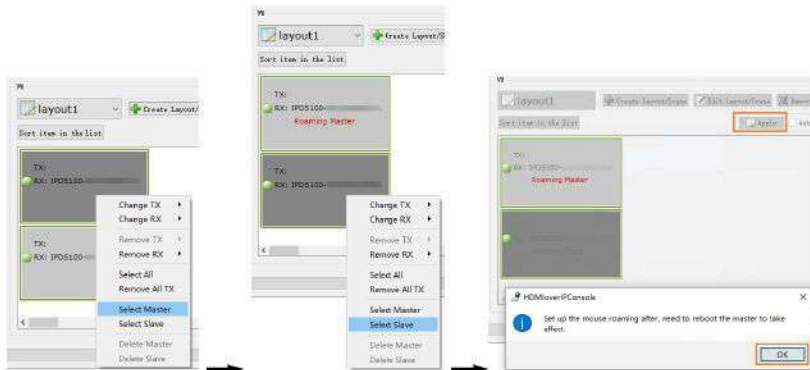

Note: To cancel Select Master (or Select Slave) setting, right click on the RX and choose **Delete Master** (or **Delete Slave**).

7. Reboot the RX for the Mouse Roaming configuration to take effect.
Select **Batch Commands** > **Others** > select RX device > **Reboot** > **Apply**.
Please wait for a few seconds for the RX device to reboot.
8. Now you can use the Master Roaming mouse to control both computers.

Configuring before HDR10/Dolby Vision Signal Input

IP5100 series support HDR10 and Dolby Vision only if the device's HDMI Timing Hybrid is set to "Pass-through" mode (default setting).

Before you input HDR10/Dolby Vision video, ensure the source and all displays support HDR10/Dolby Vision, and follow the steps below to configure the decoder(s) through PC configurator:



1. On the PC configurator, click **Batch Commands** to open Batch Commands window:

Click **Video** Tab > Choose IPD5100 devices in the **Devices** list > Click **Pass-Through** from the drop down list in **HDMI Timing Hybrid** region > click **Apply**.

Note: The default setting for HDMI Timing Hybrid is **Pass-Through**.

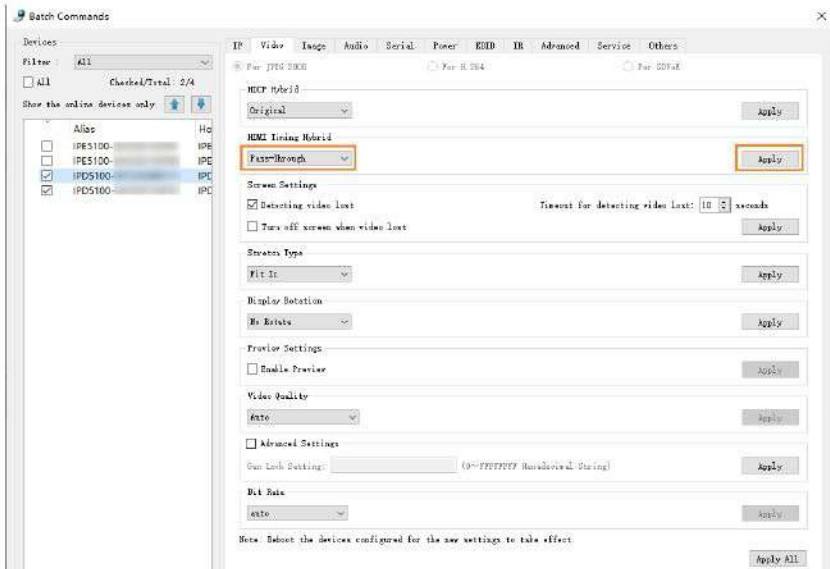

2. Reboot the above devices for new settings to take effect.
3. Upload an EDID file of HDR10 or Dolby Vision to specific encoder.

Limitation: The video preview's color in Dolby Vision Standard mode may go wrong.

Dante Audio System Configurations

An Overview of Dante

Developed by Audinate, Dante is a technology that converts audio signal into the IP (Internet Protocol) packets and transmits them over Ethernet. It allows

hundreds of channels of audio to be sent over an Ethernet cable, providing a solution of low latency, low cost, high fidelity and high expansibility for point-to-point and point-to-multipoint A/V system connections. The Dante audio products are available in the types of hardware modules, chips and software that may be integrated into a variety of products.

Before You Start

Before you want to deploy Dante system, complete the following:

- Verify that the encoders and decoders are installed with the latest firmware version.
- Complete the physical connection of the AV system.
IMPORTANT: Verify that all devices in the system are connected to the same wired network. Dante Controller is available only on a wired network.
- Download the Dante Controller software (for Dante system configuration) from the following official website.

<https://www.audinate.com/products/software/dante-controller>

Dante Audio System Applications

Application 1: Configuring Encoder to Transmit Dante Audio

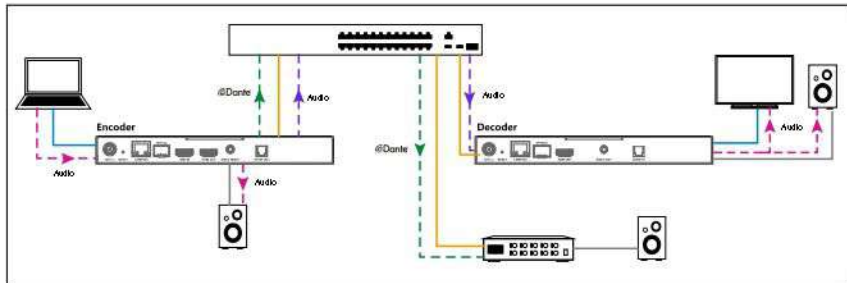

Application 1: Configuring the Encoder to Transmit Dante Audio

In Application 1, Dante is enabled on the encoder, then the encoder generates



both native audio streams and Dante audio streams; a regular decoder subscribes native audio from the encoder and plays it through HDMI and analog outputs; the Dante amplifier subscribes Dante audio and plays it through a speaker.

Configuration Steps:

1. Log on to the encoder and decoder through Telnet session.
2. Route the encoder to the decoder using API commands or PC configurator.
3. API command configuration of Dante:

For encoder:

```
/ # astparam s dante_trial_mode y #Enable Dante Trial mode**  
/ # astparam s a_addon dante #Enable Dante on encoder  
/ # astparam s a_bridge_en n #Disable Dante Bridge function  
/ # astparam s a_io_select hdmi #Select HDMI IN as audio source  
/ # astparam save #Save settings above  
/ # reboot #Reboot device for settings to take effect
```

**Note: Since the IP5100 series encoders and decoders are Dante unlicensed, users need to enable Dante trial mode first before using Dante which allows the codecs to run with Dante free for one hour. After the 1-hour trial expires, the codecs automatically reboot and start for another free trial. If the devices have been Dante licensed, ignore this command.

4. The decoder plays the audio from the encoder once they are restarted.
5. Launch Dante Controller on your computer, route Dante audio from the encoder to the Dante amplifier. Once successful, the Dante amplifier receives Dante audio from the encoder.

Application 2: Configuring Decoder to Receive Dante Audio

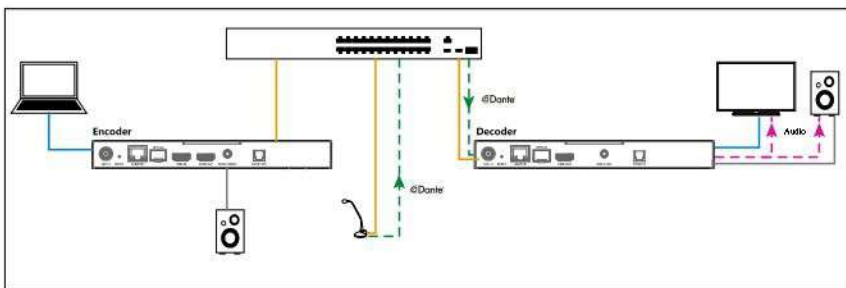

Application 2: Configuring the Decoder to Receive Dante Audio

In Application 2, Dante is enabled on the decoder and a Dante microphone is being routed to this decoder. The decoder subscribes Dante audio from the Dante microphone, decodes and outputs it through HDMI and analog ports.

Configuration Steps:

1. Log on to the decoder through Telnet session.
2. API command configuration of Dante:

For decoder:

```

/ # astparam s dante_trial_mode y #Enable Dante Trial mode
/ # astparam s a_addon dante #Enable Dante on decoder
/ # astparam s a_bridge_en n #Disable Dante Bridge function
/ # astparam s a_out_src_sel addon #Selects Dante audio as audio source
/ # astparam save #Save settings above
/ # reboot #Reboot device for settings to take effect

```

3. Launch Dante Controller on your computer, route Dante audio from the Dante microphone to the decoder. Once successful, the decoder decodes and outputs audio from the Dante microphone.

Application 3: Configuring Encoder to Bridge Dante Audio to Native Network

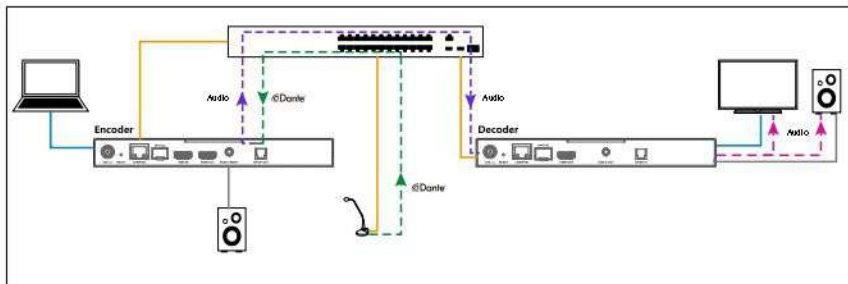

Application 3: Configuring the Encoder to Bridge Dante Audio to Native Network

In Application 3, Dante and Dante Bridge are enabled on encoder; the encoder subscribes Dante audio from the Dante microphone, bridges it to native audio stream and sends it to the decoder finally, i.e., the decoder plays the sound that originates from the Dante microphone.

Configuration Steps:

1. Log on to the encoder through Telnet session.
2. Route the encoder to the decoder using API commands or PC configurator.
3. API command configuration of Dante:

For encoder:

```

/ # astparam s dante_trial_mode y #Enable Dante Trial mode
/ # astparam s a_addon dante #Enable Dante on decoder
/ # astparam s a_bridge_en y #Enable Dante Bridge function
/ # astparam save #Save settings above
/ # reboot #Reboot device for settings to take effect

```

4. Launch Dante Controller on your computer, route Dante audio from the Dante microphone to the encoder. Once successful, the decoder plays the sound from the Dante microphone.

Application 4: Configuring Decoder to Bridge Native Audio to Dante Network

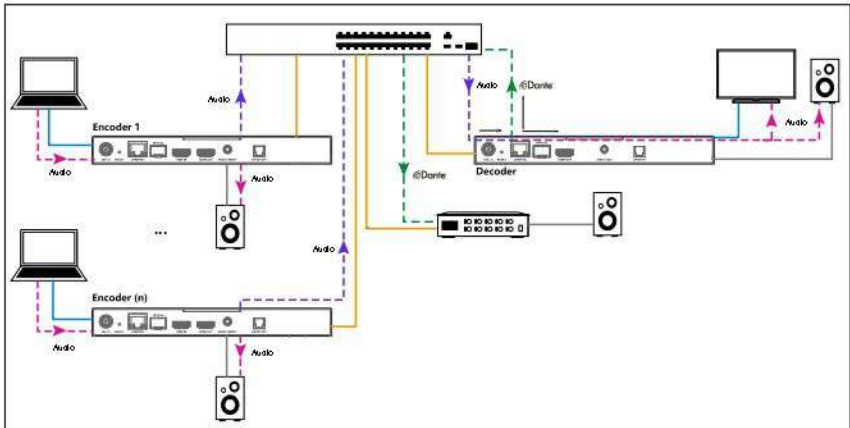

Application 4: Configuring the Decoder to Bridge Native Audio to Dante Network

In Application 4, Dante and Dante Bridge are enabled on decoder, and the decoder subscribes audio stream from the paired encoder. The audio stream on the decoder is split into two streams: one is output through HDMI and analog ports, the other is bridged to the Dante audio stream and works as a Dante source for the Dante amplifier.

Configuration Steps:

1. Log on to the decoder through Telnet session.
2. Route the encoder to the decoder using API commands or PC configurator.
3. API command configuration of Dante:

For decoder:

```

/ # astparam s dante_trial_mode y #Enable Dante Trial mode
/ # astparam s a_addon dante #Enable Dante on decoder
/ # astparam s a_bridge_en y #Enable Dante Bridge function
/ # astparam s a_out_src_sel native #Selects native audio as audio source
/ # astparam save #Save settings above
/ # reboot #Reboot device for settings to take effect

```

4. Launch Dante Controller on your computer, route Dante audio from the decoder to the Dante amplifier. Once successful, the decoder subscribes audio from the paired encoder, and the Dante amplifier subscribes Dante



audio from the decoder.

⚠ IMPORTANT: If you want to implement interoperability between HDMI audio and Dante audio, ensure that the HDMI audio's format (LPCM format & audio sampling rate) meets the requirements of that of the Dante audio.

Firmware Upgrade

You can use MaintainTool to update the encoders and decoders to their latest versions to obtain new features. For more information, see the user guide of MaintainTool.