

# User Manual

**AVPro Edge's 4 HDMI Input, 4 HDBaseT/HDMI Output Matrix Switcher with Dolby Atmos & DTS Audio Down-mixing and independent resolutions scaling and a robust user interface.**

## AC-AXION-4



Dolby, Dolby Audio, and the double-D symbol are trademarks of Dolby Laboratories.

Manufactured under license from DTS, Inc. DTS, the Symbol, DTS and the Symbol together, DTS-HD, and the DTS-HD logo are registered trademarks and/or trademarks of DTS, Inc. in the United States and/or other countries. © DTS, Inc. All Rights Reserved.

INTRODUCTION ..... 4

FEATURES ..... 4

WHATS IN THE BOX ..... 4

SPECIFICATIONS ..... 5

COMPATIBLE HDBASET RECEIVERS ..... 6

FRONT AND REAR PANEL OVERVIEW ..... 7

INITIAL SETUP: WEBUI ..... 8

ADVANCED SETUP: WEBUI INPUT SETTINGS ..... 12

ADVANCED SETUP: WEBUI OUTPUT SETTINGS ..... 13

ADVANCED SETUP: WEBUI EXTRACTED AUDIO OUTPUT SETTINGS ..... 14

WEBUI: VIDEO MATRIX ..... 16

WEBUI: AUDIO MATRIX ..... 17

WEBUI: I/O CONFIG - INPUT SETTINGS ..... 18

WEBUI: I/O CONFIG - INPUT SETTINGS CONT. .... 19

WEBUI: I/O CONFIG - OUTPUT SETTINGS ..... 19

WEBUI: I/O CONFIG - OUTPUT SETTINGS CONT. .... 20

WEBUI: I/O CONFIG - OUTPUT SETTINGS CONT. .... 21

WEBUI: I/O CONFIG - OUTPUT SETTINGS CONT. .... 22

WEBUI: SYSTEM - IP SETTINGS ..... 23

WEBUI: SYSTEM - TELNET SETTINGS ..... 24

WEBUI: SYSTEM - ADMIN WEB INTERFACE ..... 24

WEBUI: SYSTEM - USER WEB INTERFACE ..... 25

WEBUI: SYSTEM - CLOUD SERVICES ..... 26

WEBUI: SYSTEM - FIRMWARE UPDATE CONT. .... 27

WEBUI: SYSTEM - HARDWARE ..... 27

WEBUI: DIAGNOSTICS - HDMI IN ..... 28

WEBUI: DIAGNOSTICS - HDMI IN CONT. .... 29

WEBUI: DIAGNOSTICS - HDMI OUT ..... 30

WEBUI: DIAGNOSTICS - HDBT OUT ..... 31

WEBUI: DIAGNOSTICS - HDBT OUT CONT. .... 32

WEBUI: CONSOLE ..... 33

FRONT PANEL CONTROL - SWITCHING ..... 34

FRONT PANEL CONTROL - EDID ..... 35

FRONT PANEL CONTROL - AUDIO ..... 36

FRONT PANEL CONTROL - NETWORK ..... 36

FRONT PANEL CONTROL - IR REMOTE: ..... 37

IR CONTROL: ..... 37

HDBASET LIGHTS: LINK ..... 38

HDBASET LIGHTS: STATUS ..... 39

RS-232 AND TCP/IP CONTROL: ..... 40

RS-232 AND TCP/IP CONTROL: ..... 41

COMMAND LIST: ..... 42

COMMAND LIST CONTINUED: ..... 43

COMMAND LIST CONTINUED: ..... 44

EXTRACTED AUDIO: ..... 45

AUDIO OUTPUT LOGIC AND CABLE PREP: ..... 46

TROUBLESHOOTING ..... 47

BANDWIDTH CHART ..... 47

MAINTENANCE ..... 48

DAMAGE REQUIRING SERVICE ..... 48

SUPPORT ..... 49

WARRANTY ..... 49

RED TAPE. .... 50

OBTAINING AN RMA. .... 50

SHIPPING. .... 50

LEGAL STUFF. .... 50

EXCLUSIVE REMEDY ..... 51

# Introduction

The AC-AXION-4 is a high bandwidth audio/video matrix switcher. What makes this product unique is the ability to down-mix bitstream audio beyond 7.1 channel into a 2 Channel audio signal via all four inputs, including Dolby Atmos and DTS-X. This Matrix switcher's back-end interface has been completely redesigned from the ground up, allowing complete control through this Axion Web User Interface.

In a multi-zoned distribution system, every zone can not handle full Dolby Atmos sound. Most zones are going to need 2 Channel audio. The AC-AXION-4 Matrix Switcher allows you to deliver 24+ channels to your Dolby Atmos home theater; simultaneously, it provides 2 Channel to the rest of the installation. We do this by allowing the down-mixing only to affect the de-embedded audio outputs. The four mirrored HDMI/HD-BaseT ports leave the audio unimpeded, enabling you to distribute full Dolby Atmos and DTS HD through them.

Supporting the full HDMI 2.0 a/b specification and supporting every version of HDR, this matrix will ensure you can get the most out of any system.

Controlling the AC-AXION-4 is not a problem with the AVPro Edge User Interface, as you can manage all the settings and controls. We also offer drivers for all the top control systems. The AC-AXION-4 will become a staple in your large demanding installations!

## Features

- HDMI 2.0(a/b)
- 18Gbps Uncompressed Bandwidth Support on HDMI
- 18 Gbps with ICT on HDBaseT outputs
- 4K60 4:4:4 Support
- Full HDR Support (HDR 10 & 12 Bit)
- Dolby Vision, HDR10+ and HLG Support
- HDCP 2.2 (and all earlier versions supported)
- 1080p > 4K Up Scaling on HDMI outputs
- 4K > 1080p Down Scaling on HDBaseT outputs
- Advanced EDID Management
- IR, RS-232 and LAN Control Options
- Digital Toslink Out (7CH PCM, DD, DD+, DTS, DTS-MA)
- Balanced Analog Out (2 CH PCM)
- Audio Delay for Digital & Analog Out
- HDBaseT Compatibility mode for mixed systems! (More below)
- Driver Support for Crestron, C4, RTI, ELAN and more!!!
- Extracted Audio Supports DD+, DTS Master Audio on Toslink
- Extracted Audio has 3 Operating Modes. Bound to Input, Bound to Output, or Independent Matrix
- Built in Test Pattern on Each Output to Verify Infrastructure

## Whats in the box

- AC-AXION-4 Matrix
- IR Remote Control (\*No Battery Included)
- IR Extension Cable
- 48v Power Supply
- RS-232 terminal blocks
- Mounting Brackets
- Grounding Strap
- x4 AC-CABLE-5PIN-2 CH audio adapters



## Not Included

\*3V CR2025 Battery Required For IR Remote Control



# Specifications

<b>VIDEO:</b>	
VIDEO RESOLUTIONS	UP TO 4K 60HZ 4:4:4
VESA RESOLUTIONS	UP TO DCI 4K (4096X2160)
HDR FORMATS/RESOLUTIONS	420, 422, 444 (10 AND 12 DEEP COLOR) HDR10, HDR10+, DOLBY VISION, HLG
COLOR SPACE	YUV (COMPONENT), RGB (CSC: REC. 601, REC. 709, BT2020, DCI, P3 D6500)
CHROMA SUBSAMPLING	4:4:4, 4:2:2, 4:2:0 SUPPORTED
DEEP COLOR	UP TO 16 BIT (1080), UP TO 12 BIT (4K)
SCALERS (HDMI) PER OUTPUT OPTIONAL	1080P TO 4K (RESOLUTIONS ONLY, FRAMRATE STAYS THE SAME)
SCALERS (HDBASET) PER OUTPUT OPTIONAL	4K TO 1080P (RESOLUTIONS ONLY, FRAMRATE STAYS THE SAME)
<b>AUDIO:</b>	
AUDIO FORMATS SUPPORTED HDMI	PCM 2.0 CH, LPCM 5.1 & 7.1, DOLBY DIGITAL, DTS 5.1, DOLBY DIGITAL PLUS, DOLBY TRUEHD, DTS-HD MASTER AUDIO, DTS-X, DOLBY ATMOS
AUDIO FORMATS SUPPORTED EXTRACTED (TOSLINK)	ALWAYS DOWN-MIXED TO 2CH.
AUDIO FORMATS SUPPORTED EXTRACTED (2CH PORT)	ALWAYS DOWN-MIXED TO 2CH.
AUDIO EXTRACTION LOCATION	BIND TO INPUT, BIND TO OUTPUT, OR MATRIX (INDEPENDENT)
AUDIO DELAY (PER OUTPUT, EXTRACTED)	UP TO 630MS
<b>DISTANCE:</b>	
HDBASET OUT (4K60 4:4:4 & HDR) W/AC-EX70-444-RNE	70 METERS / 230 FEET (CAT 6A)
HDBASET OUT (1080P) W/AC-EX70-444-RNE	100 METERS / 330 FEET (CAT 6A)
HDBASET OUT (4K60 4:2:0 MAX) W/AC-EX70-UHD-R	40 METERS / 131 FEET (CAT 6A)
HDBASET OUT (1080P) W/AC-EX70-UHD-R	70 METERS / 230 FEET (CAT 6A)
HDMI IN/OUT (4K60 4:4:4)	UP TO 50 FEET (USING BULLET TRAIN HDMI)
HDMI IN/OUT (W/ AOC CABLE) (4K60 4:4:4)	UP TO 130 FEET (USING BULLET TRAIN AOC)
<b>OTHER:</b>	
BANDWIDTH HDMI	18 GBPS UNCOMPRESSED
BANDWIDTH HDBASET	18 GBPS (USES ICT ABOVE 10.2 GBPS SIGNALS)
HDCP	HDCP 2.2 AND EARLIER
POH FOR RECEIVERS (NO NEED TO POWER RECEIVERS)	YES, ALL OUTPUTS
<b>CONTROL:</b>	
PORTS	LAN, RS232, IR
DRIVERS	C4, RTI, ELAN, CRESTRON, URC (FOR MORE INFORMATION - SEE DRIVERS PAGE ON AVPROEDGE.COM/DRIVERS)
PC SOFTWARE	YES
LAN WEB OS	YES
<b>PORTS:</b>	
HDMI	TYPE A
HDBASET	RJ45 W/ POH FOR HDBASET RECEIVERS
LAN	RJ45 W/ WEB INTERFACE/ CONTROL
AUDIO (EXTRACTED DIGITAL)	TOSLINK
AUDIO (EXTRACTED ANALOG)	5 PIN TERMINAL BLOCK (BALANCED)
IR RX	3.5MM STEREO (3 CONDUCTOR)
RS232	3 PIN TERMINAL BLOCK
<b>ENVIRONMENTAL:</b>	
OPERATING TEMPERATURE	23 TO 125°F (-5 TO 51°C)
STORAGE TEMPERATURE	-4 TO 140°F (-20 TO 60°C)
HUMIDITY RANGE	5-90% RH (NO CONDENSATION)
<b>POWER:</b>	
POWER CONSUMPTION (TOTAL)	38 WATTS MAX
POWER SUPPLY - MATRIX	INPUT: AC 100-240V ~ 50/60HZ OUTPUT: DC 48V 1.5A
<b>DIMENSIONS:</b>	
DIMENSIONS (UNIT ONLY - HEIGHT/DEPTH/WIDTH)	MM: 50.8 X 256 X 441.33 INCH: 2 X 10.07 X 17.375
DIMENSIONS (PACKAGED HEIGHT/DEPTH/WIDTH)	MM: 88.9 X 393.7 X 495.3 INCH: 3.5 X 15.5 X 19.5
RACK UNITS	1 UNIT
WEIGHT (UNIT)	8 LBS (3.5 KG)
WEIGHT (PACKAGED)	11 LBS (5 KG)
*SPECIFICATIONS SUBJECT TO CHANGE WITHOUT NOTICE. MASS & DIMENSIONS ARE APPROXIMATE	

# Compatible HDBaseT Receivers

## AC-EX70-444-RNE (Receiver /No Ethernet)

- 70M 4k 60 4:4:4 & HDR
- 100M 1080P

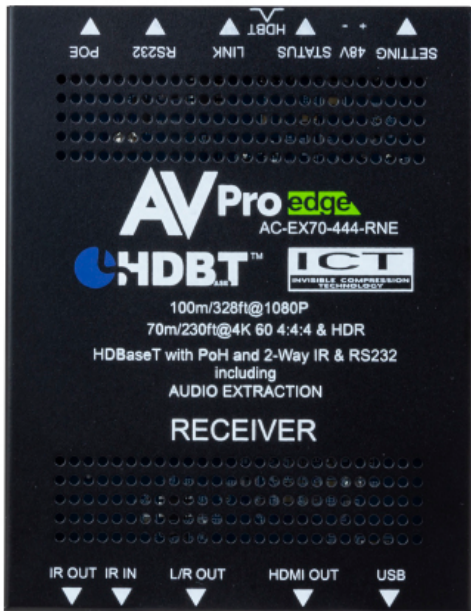

## AC-EX70-SC2-R (Scaling Receiver)

- 70M 4k 60 4:4:4 & HDR
- 100M 1080P

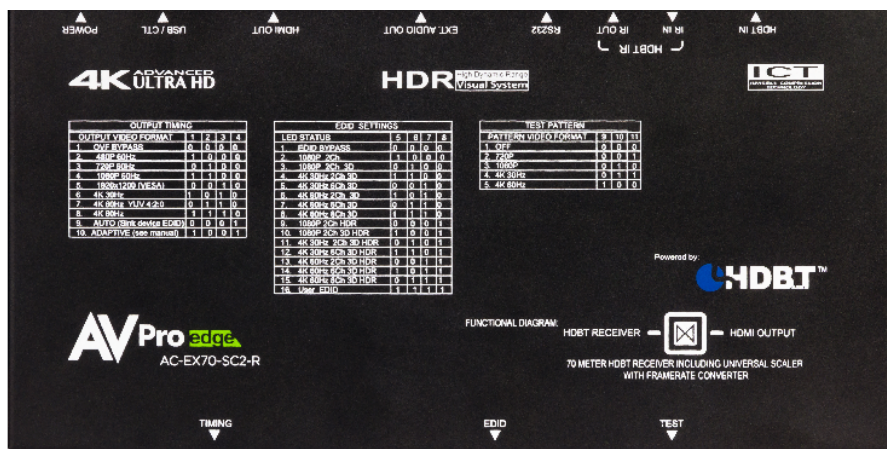

## AC-CX100-RAMP

- 70M 4k 60 4:2:0 / 4k 30 4:4:4
- 70M 1080P



## AC-EX70-UHD-R

- 40M 4k 30 4:4:4/4k 60 4:2:0
- 70M 1080P



Non AVPro HDBaseT Receivers may work but ICT (our Invisible Compression Technology) will not. This means higher bandwidth signals (greater than 10.2Gbps) will not pass as this requires ICT.

# Front and Rear Panel Overview

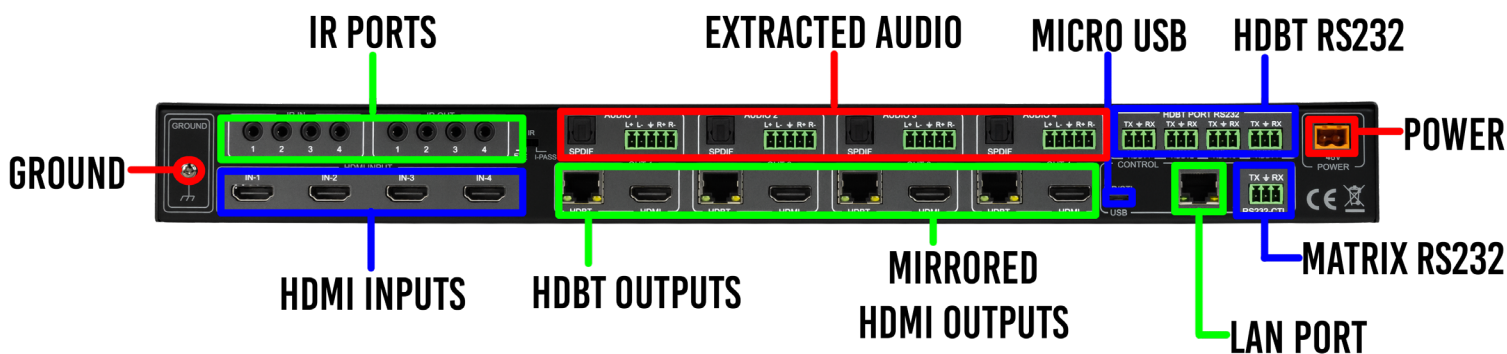
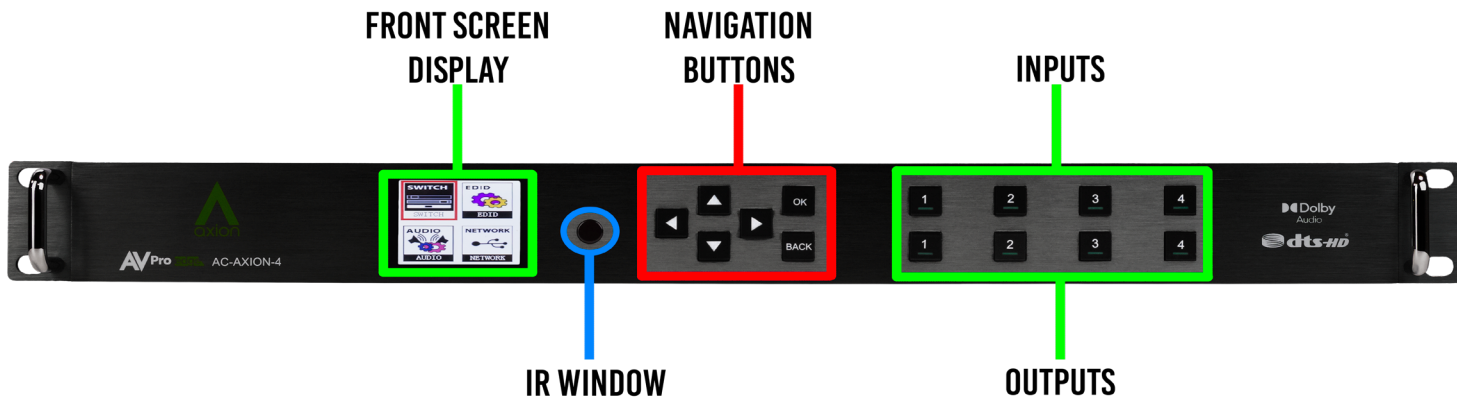

# Initial Setup: WebUI

The AC-AXION-4 can be controlled using the Micro USB port, 3pin RS232, or over TCP/IP using the LAN connection. For initial setup it is recommended to connect the matrix to a local area network (LAN) and use a computer on the same network in conjunction with the built in WebUI. After making all the physical connections, the first step will be to check for any Firmware Updates. The below steps are an example of this setup, other control options are covered in separate sections of this user manual.

1. With the AC-AXION-4 placed into its new home (AV Rack, cabinet, table top) take a Phillips head screwdriver and attach the included yellow ground strap to the back of the chassis using the pre-installed screw, then attach the other end to a suitable grounded object.



2. Connect the HDMI Input sources to the HDMI Inputs on the back of the matrix.
3. Connect the HDMI/HDBaseT devices to the HDMI/HDBaseT Outputs.
4. Connect the network LAN cable to the RJ45 port labeled LAN (between the Micro USB and 3pin RS232 port).
5. Power on the sources (Inputs).
6. Power on the Output devices/displays.
7. Connect the 48V power supply to power on the matrix and then to a suitable power source.
8. Using the front panel display and control/arrow buttons navigate to NETWORK and press the OK button to enter the IP Settings menu.

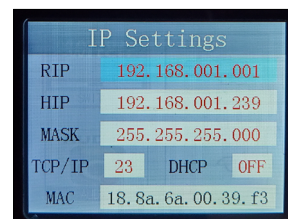
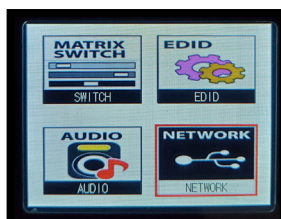

9. Either manually enter in your desired IP settings, or enable DHCP and let your network assign the correct settings. Use the UP/DOWN arrow keys to highlight the row you want to change (HIP, RIP, TCP Port, etc), click OK, use left/right arrow keys to select and the UP/DOWN arrow keys to change the setting. Click the OK button again to confirm those changes.
10. With the matrix connected to the local network, using a computer on the same network open up a web browser and type the HIP (Host IP Address) into the address bar to navigate to the WebUI.

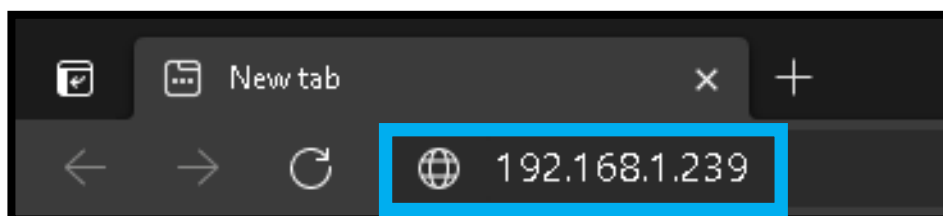

11. With the Axion WebUI open, navigate to System. Click on the Privacy Policy and Terms of Use, this will open these documents in a new tab for review. Once read click on the boxes next to each to agree. When both are checked the switch for Enable Cloud Services will be selectable (will be red or disabled by default). Click to enable (the switch will turn green).

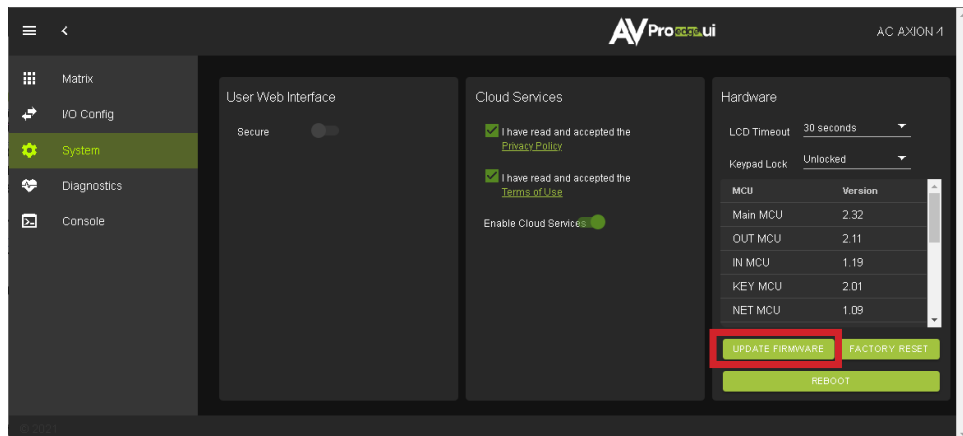
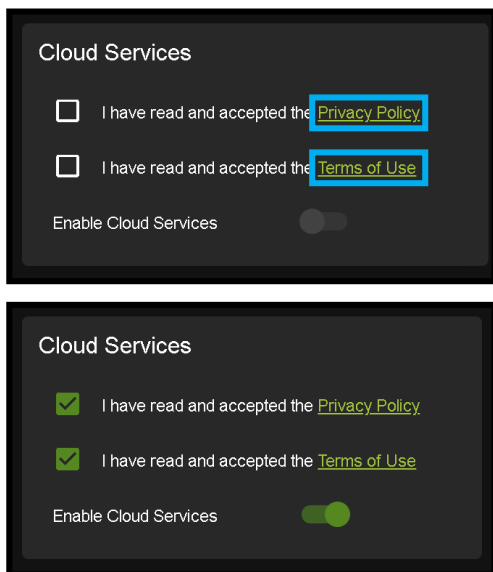

12. With the Cloud Services enabled under the Hardware section click the **Update Firmware** button to check for new Firmware OTA (over the air). This will compare the firmware versions currently loaded on the AC-AXION-4 and compare to the latest available. If it is up to date, you will see a prompt stating "No update available!"



13. If an update is available, the following prompt will show. Simply click **UPDATE**.



14. If a new update is available a file will automatically be selected, simply click the **UPLOAD** button to load the firmware files to the Matrix. Uploading does not install the Firmware, that is the next step.

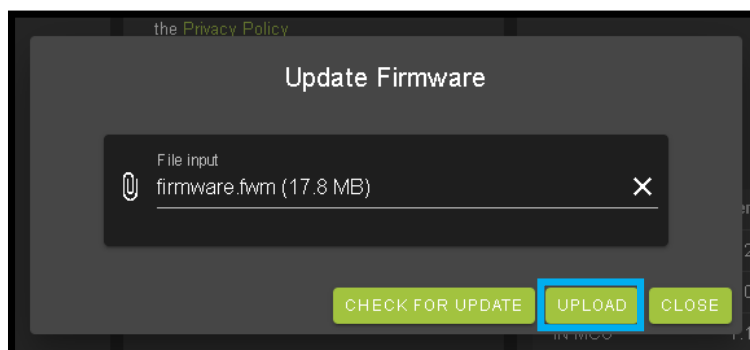

- Once the firmware file has been uploaded, it will display all containing firmware files. Here you can select individual firmware files to load or simply leave all files/options selected. If the version currently installed is not newer (does not need to be updated), then that update will be skipped automatically. Click the **UPGRADE** button to start.

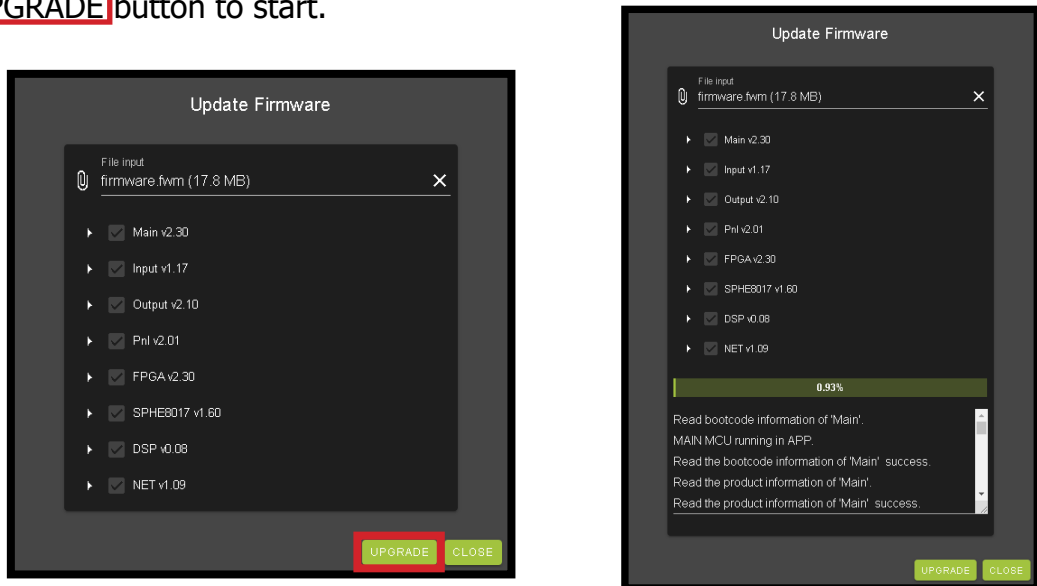

- Once the progress bar hits 100% click the CLOSE button, the firmware upgrade process is complete.
- With the Firmware up to date it's time to start setting up the matrix. With the Axion WebUI open, navigate to the I/O Config section. Label the applicable Inputs (Apple TV, Cable Box, Roku, etc) under the **Input Settings - Label**.

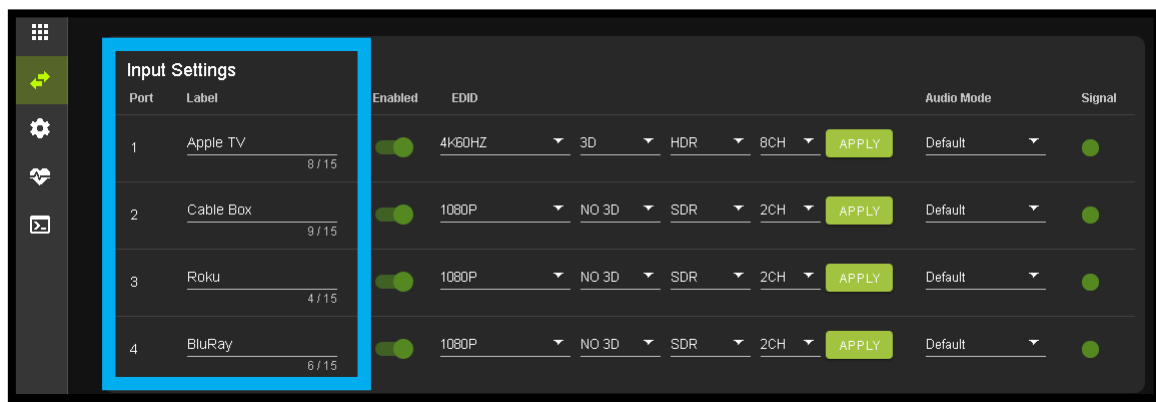

- Label the Outputs (Living Room, Bedroom, Den, etc) under the **Video Output Settings - Label**.

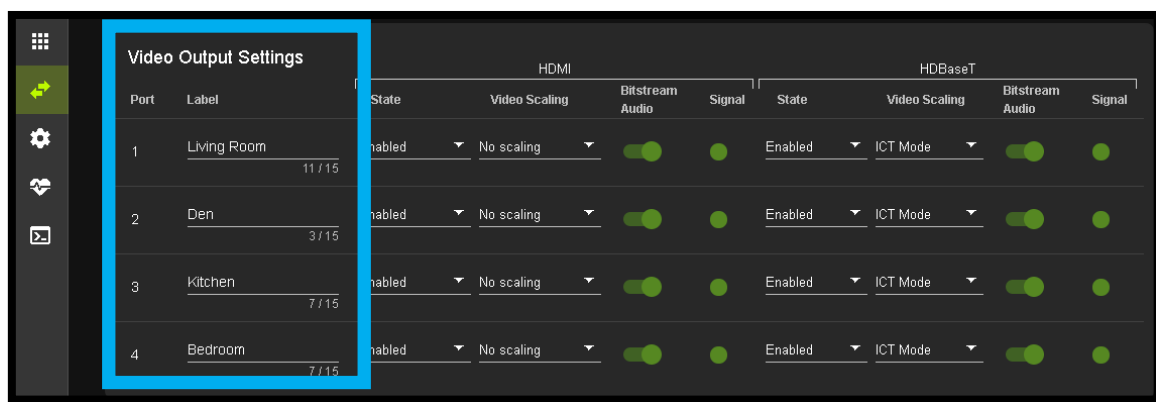

- Set the HDMI/HDBaseT Video Scaling if needed. HDMI outputs can be upscaled (1080P signal up to 4k) and the HDBaseT outputs can be downscaled (4k signals down to 1080P).

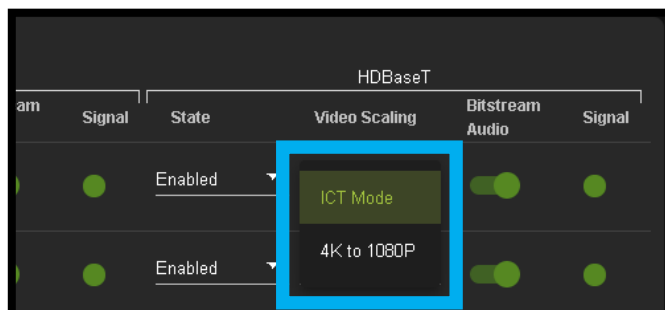
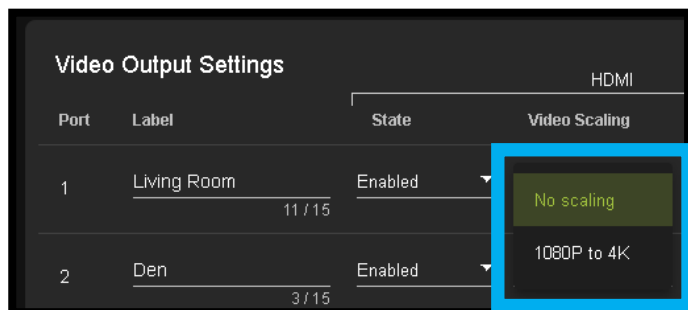

- With the system and all its components powered up it's time to verify signal path from source to the sync. For now leave EDID settings to their default 1080P 2 CH, the next section Advanced Setup will cover the more advance settings.

- Use the Signal Indicator on the HDMI INPUTS. Green means HDMI source is detected, red means that the source is not detected. If red verify that the input is powered on and that the HDMI cable is properly connected to the source and to the back of the matrix.



- Now verify the connections to the HDMI/HDBaseT outputs using the Signal indicator. Green means HDMI/HDBaseT sync is detected, red means that the HDMI/HDBaseT sync is not detected. If red verify that the sync devices are powered on and that the HDMI/HDBaseT cables are properly connected to the back of the matrix.

- With everything connected and powered on, green indicators across the applicable inputs and outputs, verify you are getting all of your sources on all of your displays.

- Problems with a source or sync, see the Troubleshooting section for help on page 45.

# Advanced Setup: WebUI Input Settings

After verifying good signal path from source to sync now it is time to go through the rest of the settings to maximize the setup. Starting with the input side with the EDID and Audio Mode settings.

1. With the WebUI open, navigate to the I/O Config tab and focus on the Input Settings section at the top.
2. Set the EDID on each input by selecting the resolution drop-down first (default is set to 1080P). The options are 1080P, 4K30Hz, 4K60Hz Y420, and 4K60Hz. If you select USER1 EDID, then the drop-downs change to allow you to select from and output to copy from. You can select any of the 4 HDMI outputs, or any of the 4 HDBaseT outputs, then click the COPY button. This will save that outputs EDID to the USER1 slot.
3. Next use the drop-down to select NO 3D, or 3D depending on the displays capability.  
NOTE: Currently the only resolution you can choose NO 3D for is 1080P.
4. Next drop-down select either SDR (standard dynamic range) or HDR (High Dynamic Range).
5. The fourth drop-down in the EDID section is for the audio, you can select 2 CH, 6CH, or 8CH.
6. Click the APPLY button to set the EDID.

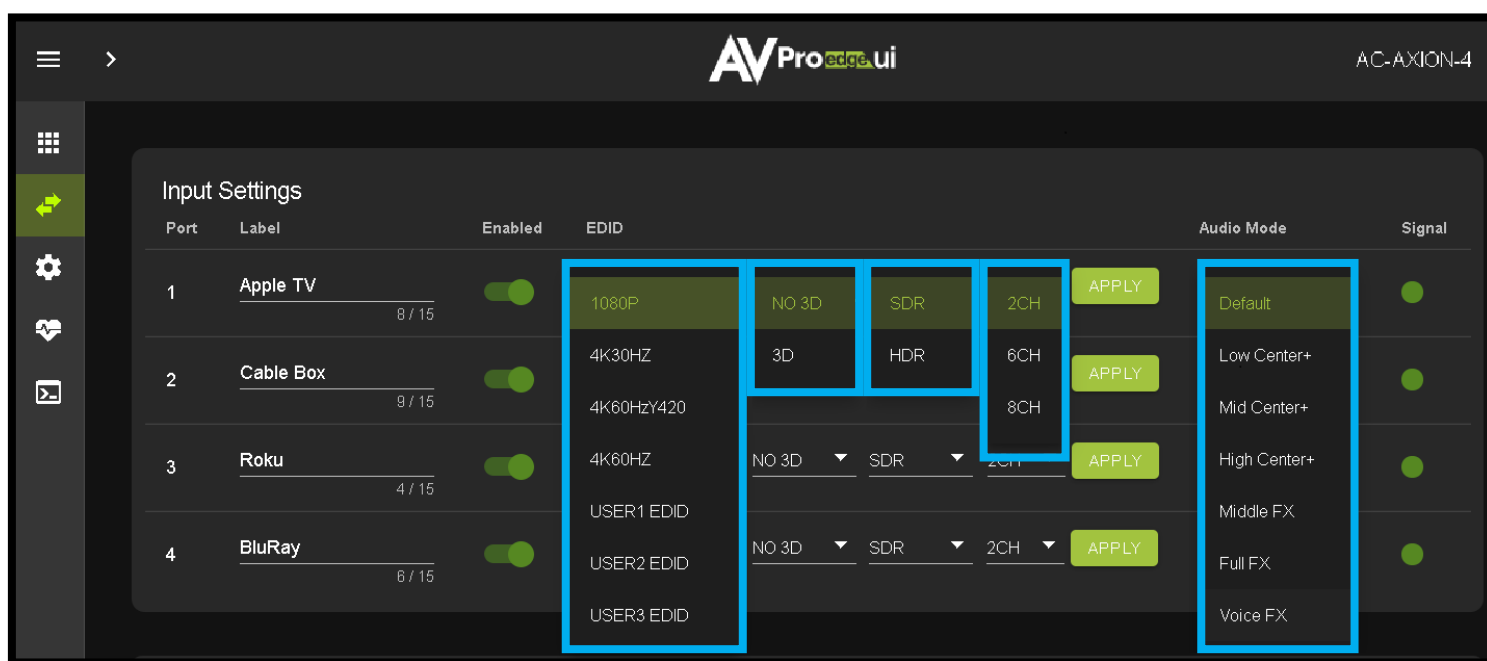

7. Verify you are still getting that source to all your displays and that the image looks correct.

NOTE: Some older displays may take an HDR signal and display correctly (ignoring the HDR Metadata) others will not ignore the HDR part of the signal and may display incorrectly.

Audio Mode - see Page 19 ["Input Settings - Audio Mode"](#) for more info.

# Advanced Setup: WebUI Output Settings



- Now navigate to the Video Output Settings under I/O Config
- In addition to the output Label (name/alias), there are 3 settings for each HDMI output and 3 settings for each HDBaseT output.

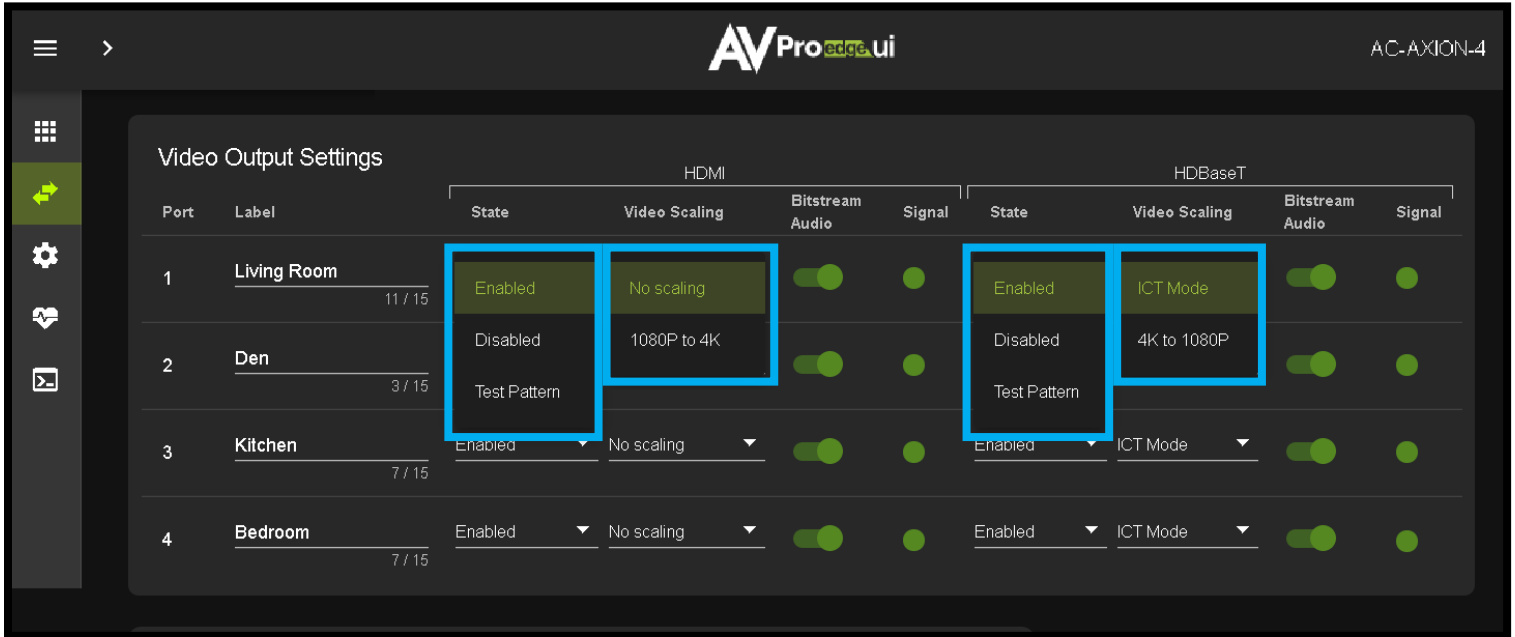

- Under State, you can enable/disable that port (turn that port on or off) and also enable a 1080P test pattern, the Video Scaling mode (HDMI you can choose to No Scaling or 1080P to 4k, HDBaseT you can choose ICT or 4K to 1080P), and you can Enable or Disable the Bitstream Audio (slider icon Green=ON, Red=OFF).

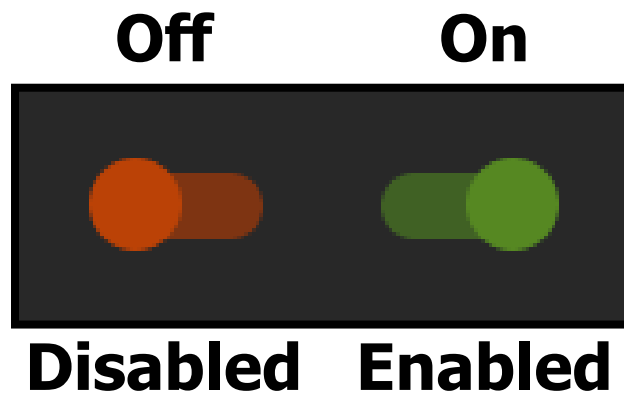

# Advanced Setup:

## 1. WebUI Extracted Audio Output Settings

1. Now navigate to the Extracted Audio Output Settings under I/O Config.
2. The extracted audio ports have 3 distinct operating modes, use the drop-down at the top to select. The three options are.

**Bind to Input (Default)** - where the audio port number corresponds to the input signal. This is ideal for systems where audio is matrixed separately in a zoned amplifier.

**Bind to Output** - this configuration the audio will automatically follow the HDMI/HDBaseT output. This is ideal for systems that use local AVR's for some of the Zones.

**Matrix** - This mode allows you to matrix the extracted audio ports independently from the HDMI/HDBaseT outputs. In this mode you there will be a Tab for the extracted audio under the Matrix page, allowing you to route the audio just like routing the video. If the matrix is set to Bind to Input or Bind to Output this tab will not be visible.

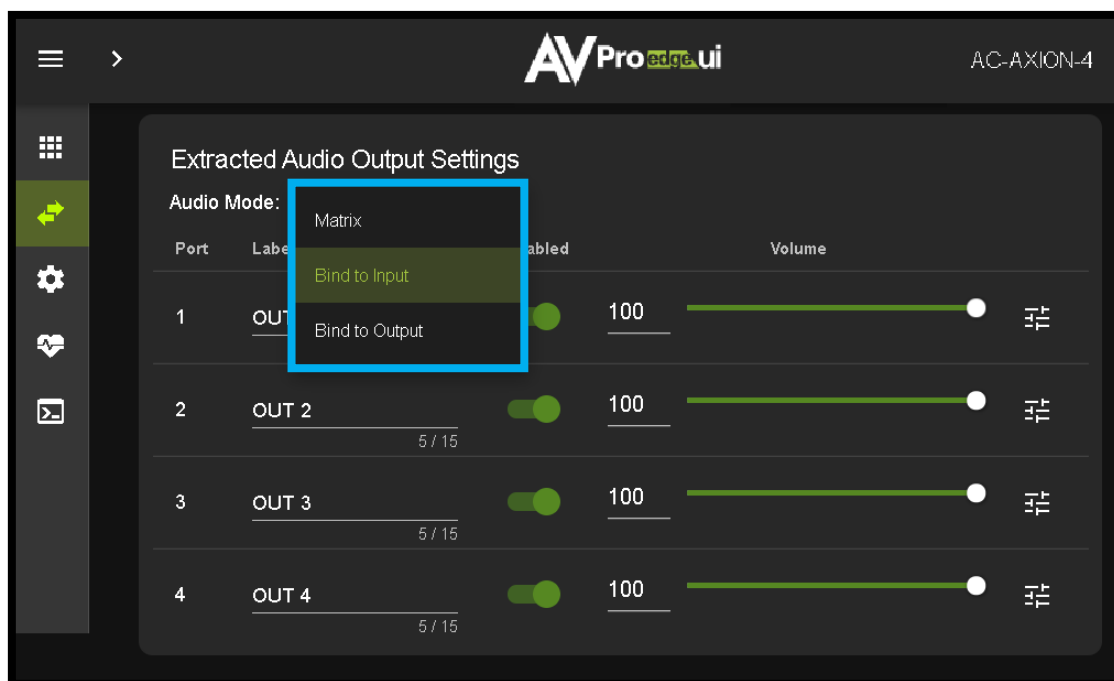

3. Other available settings for the extracted audio ports include Enable/Disable, Volume control (1-100), EQ presets (7 generic preset options to choose from), Left/Right balance, and audio delay. Each of these 5 settings can be changed per extracted audio port.

NOTE: The balanced 5pin and Toslink ports are mirrored and always down-mixed to 2 CH audio.

4. You can use the slider or text box to change the volume (settings are 0-100).

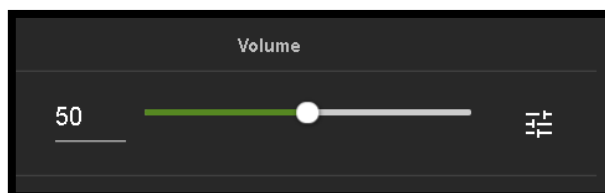

- To change the EQ settings of that port click on the **emblem** to the right of the volume slider. This will bring up the Audio Configuration Page. Here you can choose from 8 different EQ settings, change the Left / Right balance, and set the audio delay.

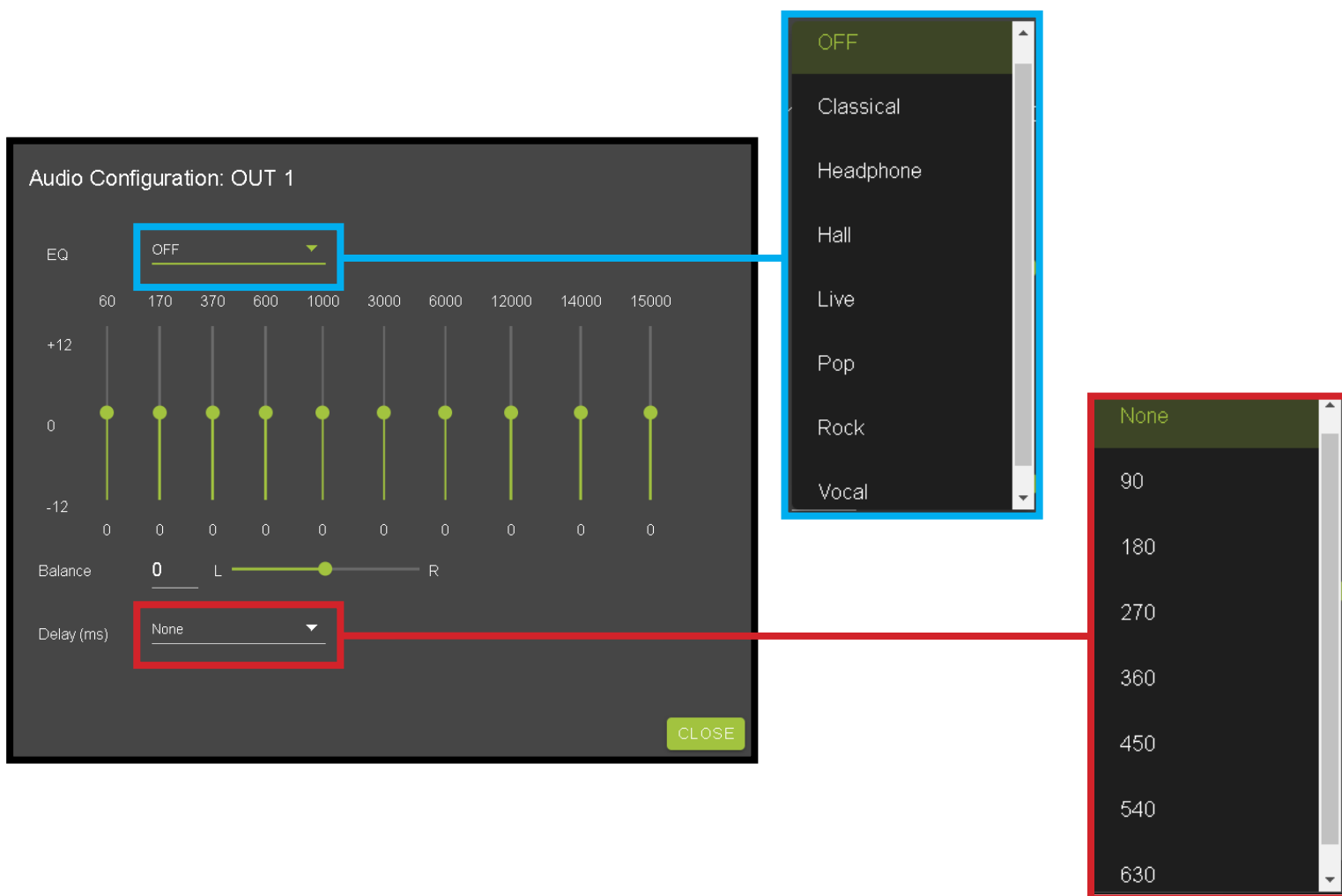
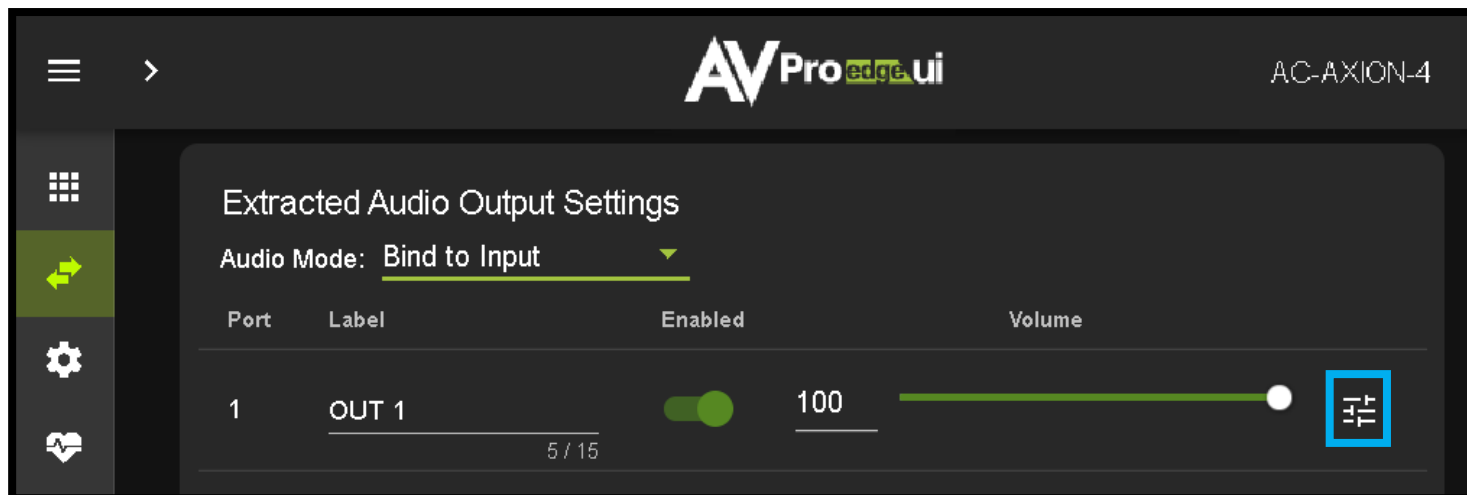

- Delay (eight settings in 90 millisecond increments)  
None (default), 90, 180, 270, 360, 450, 540, and 630.

# WebUI: Video Matrix

Use this page to route the video INPUTS and OUTPUTS.

- Click on the INPUT number to select (example below shows IN 1)

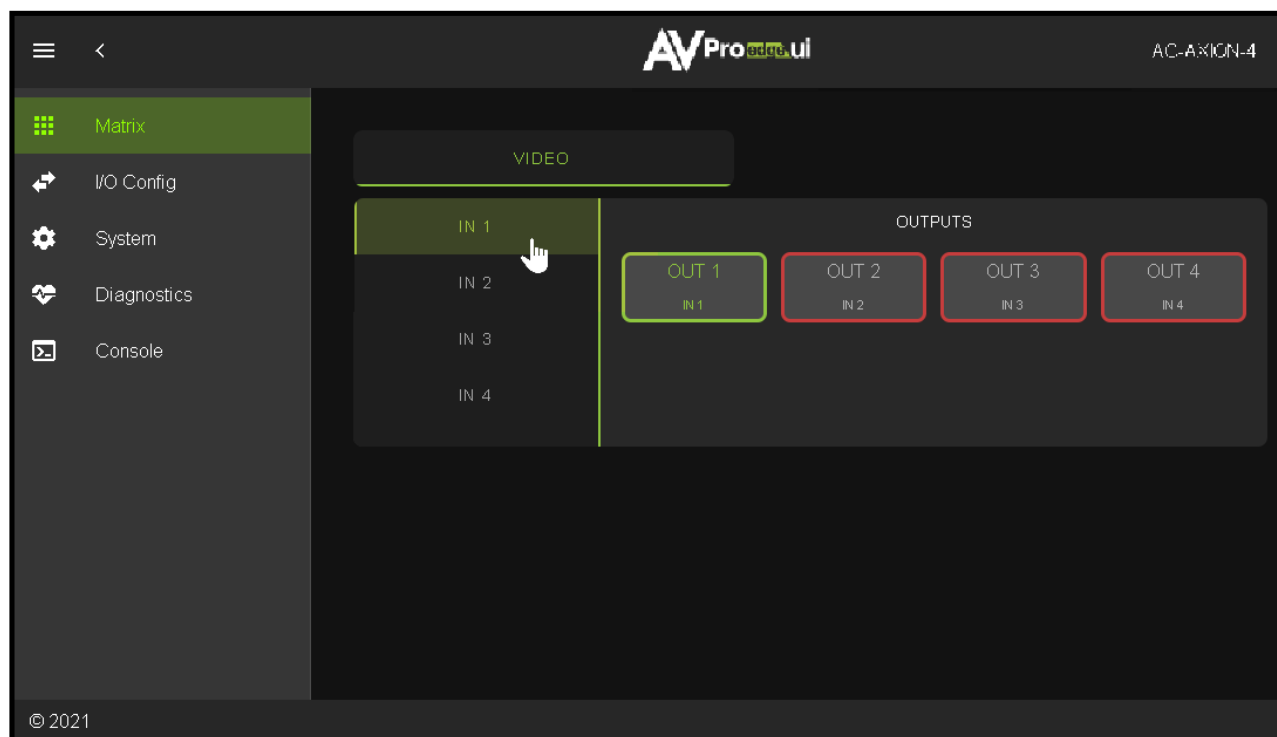

- With the INPUT selected simply click on the OUTPUT you want to send that source to.

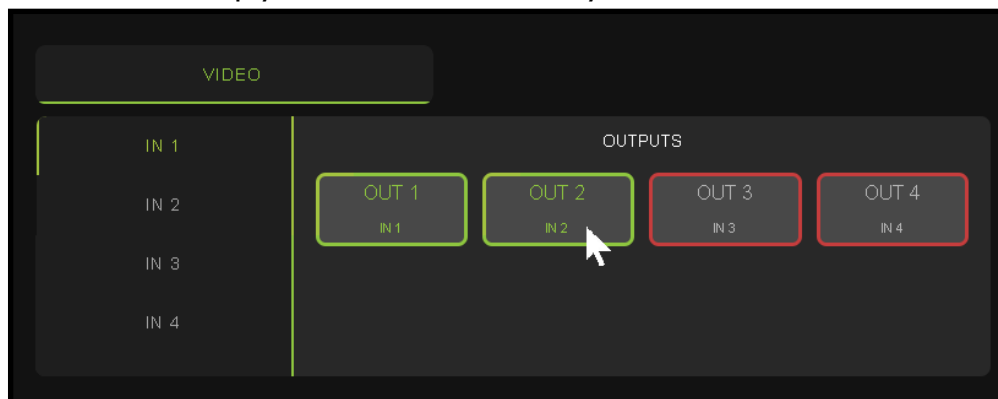

- Note: If you rename the INPUTS/OUTPUTS using the I/O Config page they will display here.

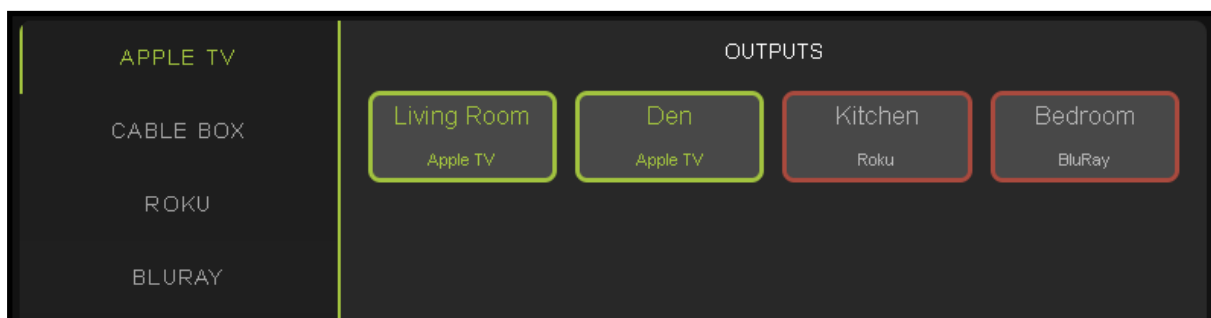

# WebUI: Audio Matrix

Use this page to route the extracted audio.

NOTE: The extracted audio ports can only be manually changed (matrixed) when in Matrix Mode. If the extracted audio is set to Bind to Input (default) or Bind to Output then this tab will not be visible, example below. See Page 14 "[Advanced Setup: WebUI Extracted Audio Output Settings](#)" for more info.

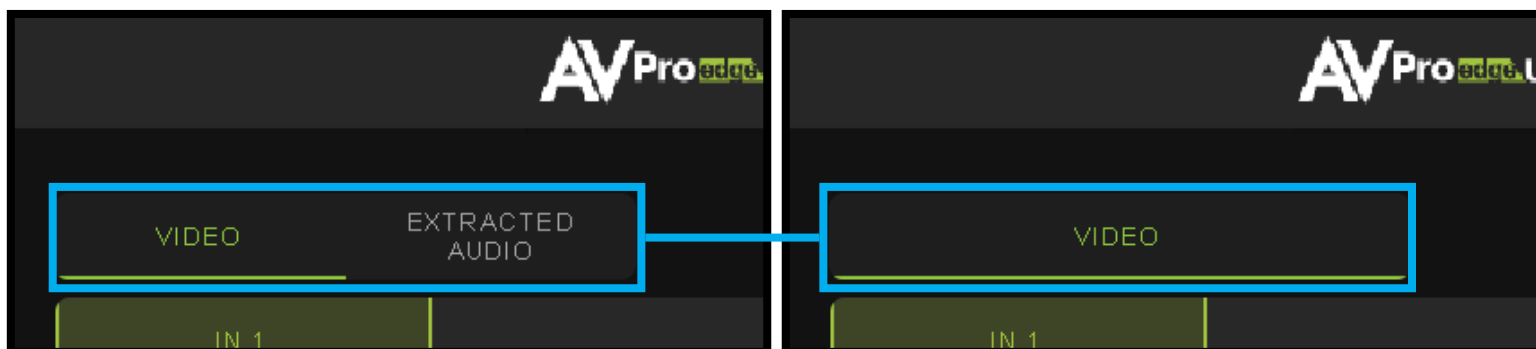

- Click on the INPUT number to select (example below shows IN 1 - Apple TV)
- With the INPUT selected simply click on the OUTPUT you want to send that audio to.
- Note: If you rename the INPUTS/OUTPUTS using the I/O Config page they will display here.

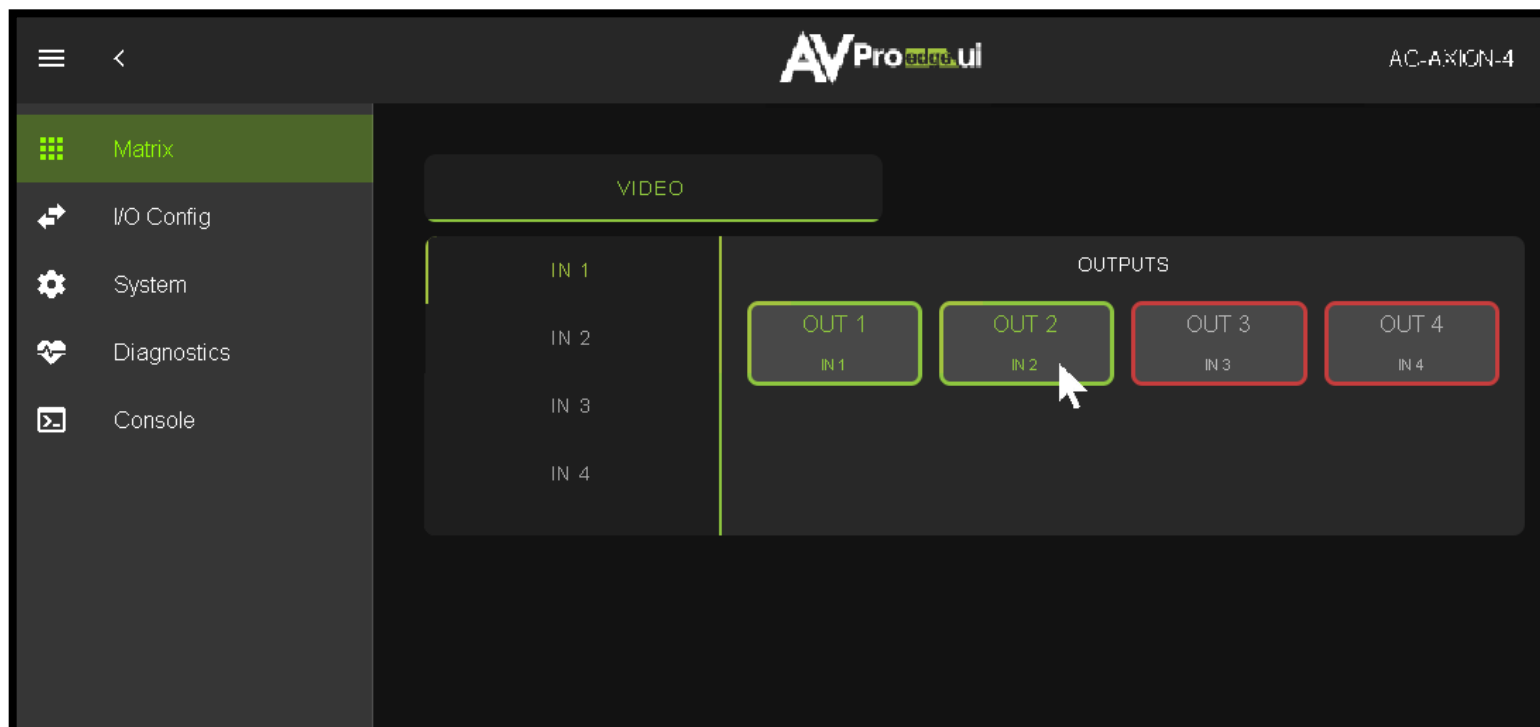

# WebUI: I/O Config - Input Settings



**Input Settings Label** - Use this to give an name/alias to your inputs (Apple TV, Cable Box, Roku, etc). Note: There is a 15 character limit to this field, the name will replace the default "IN #" throughout the rest of the WebUI (for instance the Video Matrix tab).

**Input Settings Enable switch** - Use this enable/disable switch to turn the corresponding Input port on or off. The default setting is enabled (green) by default.

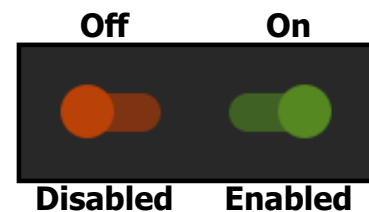

**Input Settings EDID** - Use these four drop-downs to select your preferred EDID. The available combinations are as follows.

- |                   |                        |                        |                            |
|-------------------|------------------------|------------------------|----------------------------|
| 1. 1080P_2 CH     | 9. 4K30HZ_3D_8CH       | 17. 1080P_6CH_HDR      | 25. 4K60HzY420_3D_2 CH_HDR |
| 2. 1080P_6CH      | 10. 4K60HzY420_3D_2 CH | 18. 1080P_8CH_HDR      | 26. 4K60HzY420_3D_6CH_HDR  |
| 3. 1080P_8CH      | 11. 4K60HzY420_3D_6CH  | 19. 1080P_3D_2 CH_HDR  | 27. 4K60HzY420_3D_8CH_HDR  |
| 4. 1080P_3D_2 CH  | 12. 4K60HzY420_3D_8CH  | 20. 1080P_3D_6CH_HDR   | 28. 4K60HZ_3D_2 CH_HDR     |
| 5. 1080P_3D_6CH   | 13. 4K60HZ_3D_2 CH     | 21. 1080P_3D_8CH_HDR   | 29. 4K60HZ_3D_6CH_HDR      |
| 6. 1080P_3D_8CH   | 14. 4K60HZ_3D_6CH      | 22. 4K30HZ_3D_2 CH_HDR | 30. 4K60HZ_3D_8CH_HDR      |
| 7. 4K30HZ_3D_2 CH | 15. 4K60HZ_3D_8CH      | 23. 4K30HZ_3D_6CH_HDR  |                            |
| 8. 4K30HZ_3D_6CH  | 16. 1080P_2 CH_HDR     | 24. 4K30HZ_3D_8CH_HDR  |                            |

**NOTE:** If you select USER1 EDID, then drop-downs change to allow you to select from and output to copy from. You can select any of the 4 HDMI outputs, or any of the 4 HDBaseT outputs, then click the COPY button (this replaces the Apply button). This will save that outputs EDID to the USER1 slot.

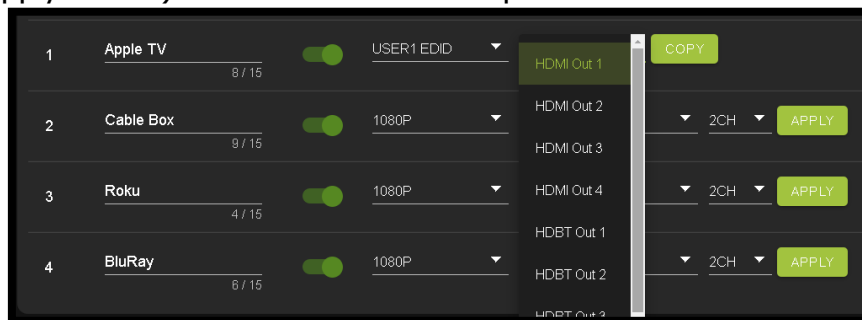

# WebUI: I/O Config - Input Settings Cont.

**Input Settings Audio Mode** - There are 7 settings available (Default state is off/disabled).

The AC-AXION-4 automatically down-mixes the source audio signals down to 2 CH. for the extracted audio Toslink and balanced 5pin ports. Changing the audio mode here will affect that inputs audio on all the extracted ports.

Default (off), Low Center+, Mid Center+, High Center+, Middle FX, Full FX, and Voice FX.

NOTE: There are also EQ, Balance (left/right), and Delay settings you can change per Output, see WebUI: I/O Config - Output Settings on pages 20-21 for more info.

**Input Settings Signal** - The Signal Indicator on the HDMI INPUTS shows the current state of the connection HDMI source. Green means the HDMI source is detected, red means that the source is not detected. If red verify that source is powered on and that the HDMI cable is properly connected to the source and to the back of the matrix.



**Global Input Settings** - There are two settings available

- Supports Dolby MAT - Check this box to enable Dolby MAT audio
- Requires Dolby Vision Low Latency - Check this box to require Dolby Vision Low Latency (Player-led) over Standard Dolby Vision (TV-Led). Sources like the Apple TV and X-Box Series X use Low Latency.

# WebUI: I/O Config - Output Settings

Video Output Settings		HDMI			
Port	Label	State	Video Scaling	Bitstream Audio	Signal
1	OUT 1 5 / 15	Enabled	No scaling	<input checked="" type="checkbox"/>	<input type="checkbox"/>
2	OUT 2 5 / 15	Enabled	No scaling	<input checked="" type="checkbox"/>	<input type="checkbox"/>
3	OUT 3 5 / 15	Enabled	No scaling	<input checked="" type="checkbox"/>	<input type="checkbox"/>
4	OUT 4 5 / 15	Enabled	No scaling	<input checked="" type="checkbox"/>	<input type="checkbox"/>

**Output Settings Label** - Use this to give an name/alias to your outputs (Living Room, Den, Kitchen, etc).

Note: There is a 15 character limit to this field, the name will replace the default "OUT #" throughout the rest of the WebUI (for instance the Video Matrix tab).

**Output Settings State** - This drop-down has 3 settings, just like the input settings you can Enable or disable this port. In addition you can also choose Test Pattern to enable a 1080P color bar test pattern on that output. This is helpful in verifying the signal chain from Matrix to sync (display). To disable the test pattern, change the state back to Enabled (default).

# WebUI: I/O Config - Output Settings Cont.

**Output Settings Video Scaling** - The HDMI outputs can up-scale a 1080P signal to 4k. This scaling only changes the pixel density, it does not alter frame rate or color space.

**Output Settings Bitstream Audio** - This is an enable/disable switch. By default this will be Enabled/Green. To change the setting simply click to switch. Disabled/Red there will be no Audio passed on that HDMI output.

NOTE: This setting has no affect on the HDBaseT or Extracted Audio output.

**Output Settings Signal** - The Signal Indicator on the HDMI OUTPUTS shows the current state of the connection HDMI Output. Green means HDMI sync is detected, red means that the sync is not detected. If red verify that the output is powered on and that the HDMI cable is properly connected to the sync and to the back of the matrix.

**Output Settings State** - This drop-down has 3 settings, just like the input settings and HDMI outputs you can Enable or Disable this port. In addition you can also choose Test Pattern to enable a 1080P color bar test pattern on that output. This is helpful in verifying the signal chain from Matrix to sync (display). To disable the test pattern, change the state back to Enabled (default).

**Output Settings Video Scaling** - The HDBaseT outputs can down-scale a 4K signal to 1080P. This scaling only changes the pixel density, it does not alter frame rate or color space. The other setting is ICT Mode (default), AVProEdge's Invisible Compression Technology designed to work with a compatible AVProEdge HDBaseT Receiver (RX).

**Output Settings Bitstream Audio** - This is an enable/disable switch. By default this will be Enabled/Green. To change the setting simply click to switch. Disabled/Red there will be no Audio passed on that HDBaseT output.

**Output Settings Signal** - The Signal Indicator on the HDBaseT outputs shows the current state of the connected HDBaseT Receiver. Green means HDBaseT receiver is detected, red means that the receiver is not detected. If red verify that the category cable is properly terminated on both ends, and properly connected to both the matrix and the HDBaseT receiver.

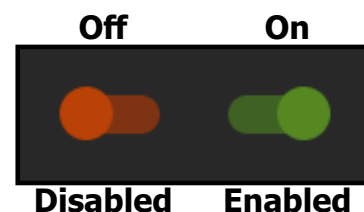
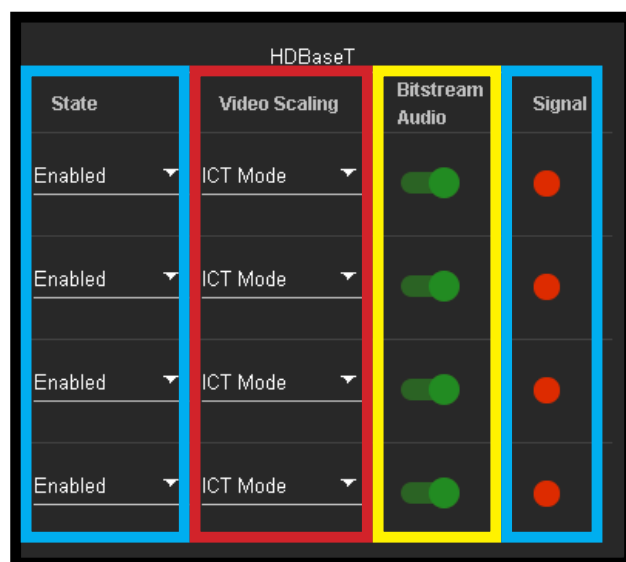

# WebUI: I/O Config - Output Settings Cont.

**Output Settings Label** - Use this to give an alias/name to your extracted audio outputs.

Note: There is a 15 character limit to this field, the name will replace the default "OUT #" throughout the rest of the WebUI (for instance the Video Matrix tab).

**Output Settings Enabled** - This is an enable/disable switch. By default this will be Enabled/Green. To change the setting simply click to switch. Disabled/Red there will be no Audio passed on that extracted audio port (both Toslink and balanced 5pin will be muted).

**Output Settings Volume** - Here you can use the slider bar to adjust the extracted port volume (0~100). You can also use the text box and enter a value (0~100).

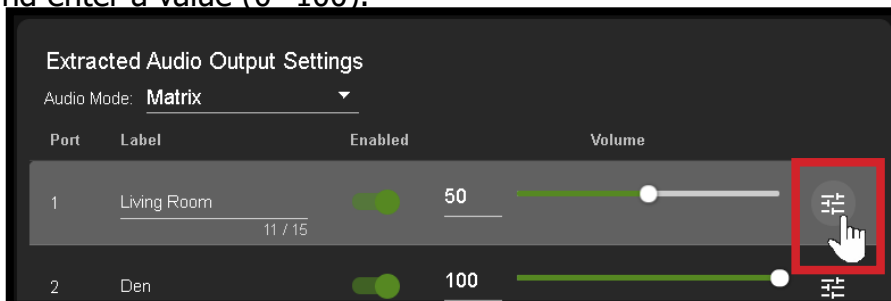

**Output Settings EQ Settings** - To open the EQ Settings click on the **symbol** next to the Volume slider.

**EQ Drop-down** contains 8 settings. The default off, Classical, Headphone, Hall, Live, Pop, Rock, and Vocal.

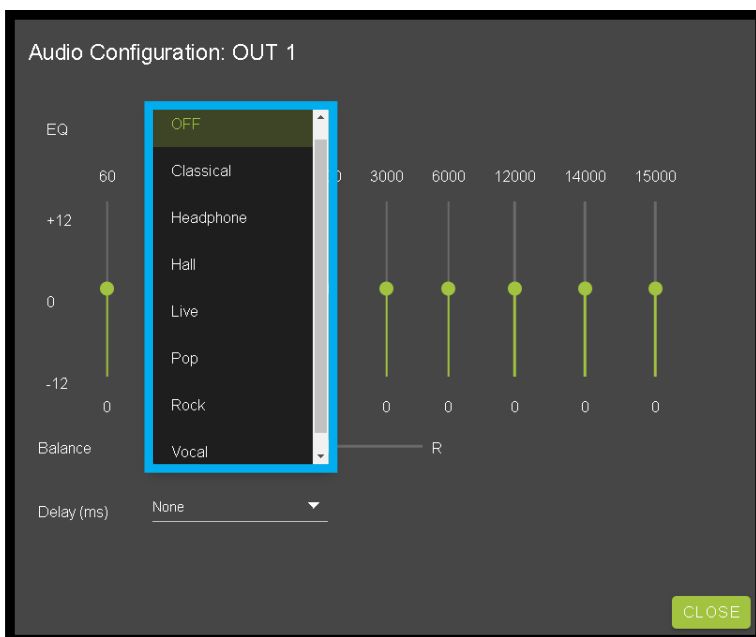
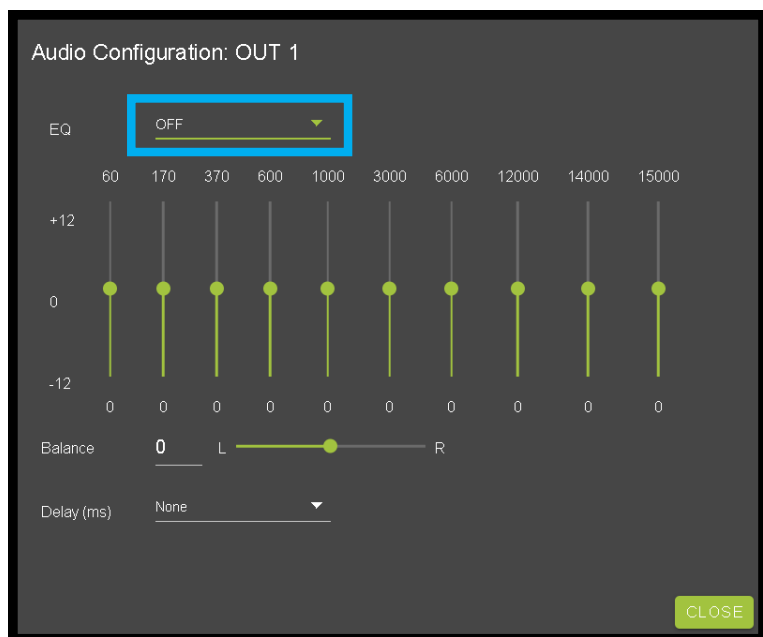

# WebUI: I/O Config - Output Settings Cont.

**Output Settings Balance** - Use this **slider** to adjust the Left/Right balance.

Note: Default is 0 (zero), value can be -10~10

**Output Settings Delay (ms)** - Audio delay **drop-down** has eight available settings, these are measured in milliseconds.

None (default), 90ms, 180ms, 270ms, 360ms, 450ms, 540ms, and 630ms.

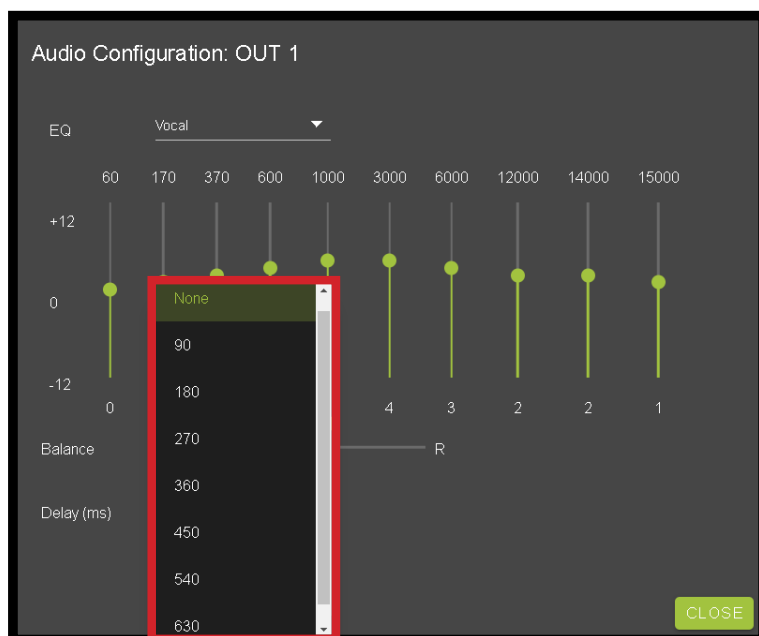
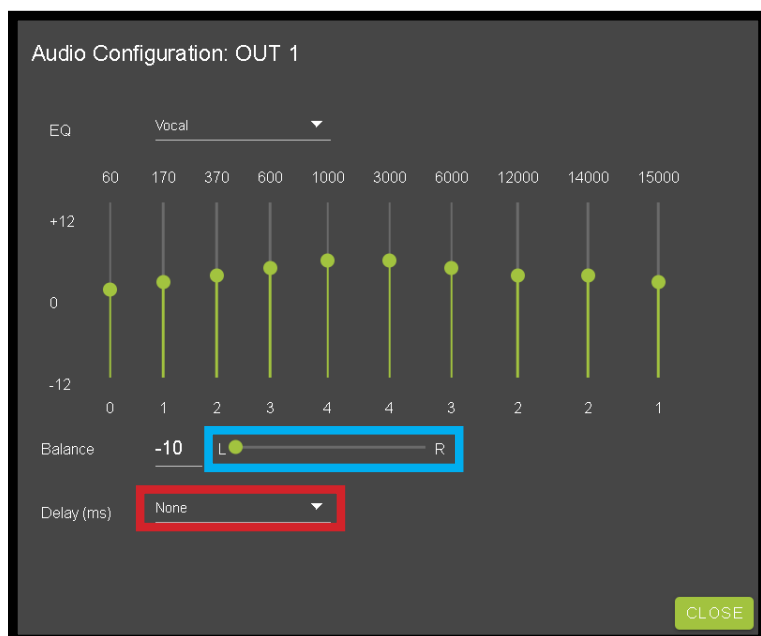

# WebUI: System - IP Settings

This area contains relevant network information of the AC-AXION-4.

**Host Name** - Devices name on the network. This field is automatically filled with Model Name by default.

**Model Name** - Displays the AVProEdge Model/Part number.

**Serial Number** - Displays the Serial Number of the matrix.

**MAC Address** - Displays the devices MAC Address.

**IP assignment** - This drop-down has two options.

1. Manual
2. Automatic (DHCP)

Default out of the box will be set to Automatic (DHCP), the IP Address, Subnet Mask, Gateway, Primary DNS, and Secondary DNS will be assigned by your network controller. If you select Manual, you can use the text fields to enter your own Network settings. Once all fields have been filled out, click the green Apply Button to set. A prompt will appear to confirm the change, click OK to confirm.

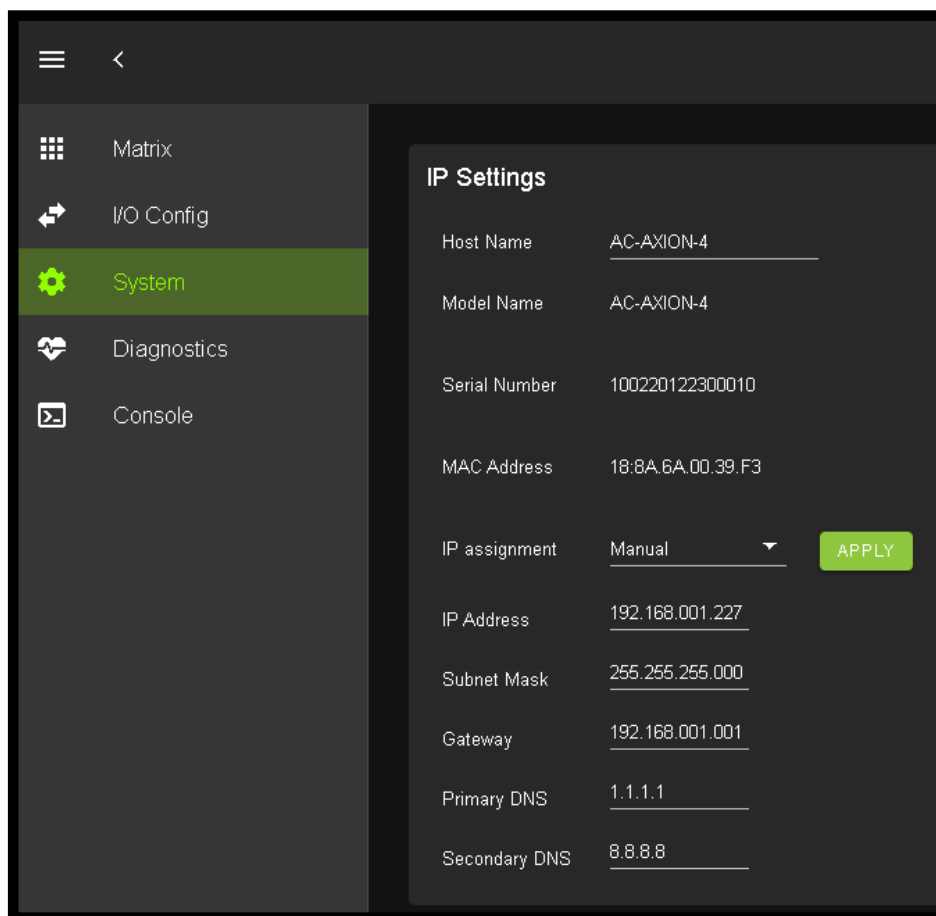

# WebUI: System - Telnet Settings

This area contains relevant Telnet settings for the AC-AXION-4. There are two fields that can be changed, Enable/Disable switch and the Port Number.

- Enable - This switch has two options, Green/Enabled (Default) and Red/Disabled.
- Port - This field is used to change the Telnet Port of the AC-AXION-4. You can use the text field to enter a number or use the Up/Down arrow buttons to increase/decrease the number.

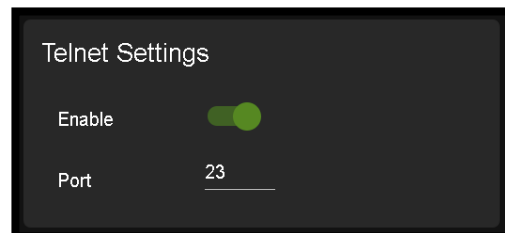

# WebUI: System - Admin Web Interface

This switch has two options, Red/Disabled (Default) and Green/Enabled. When enabled (green) there will be three fields that appear, Username, Password, and Confirm Password.

Default Username - admin

Default Password - admin

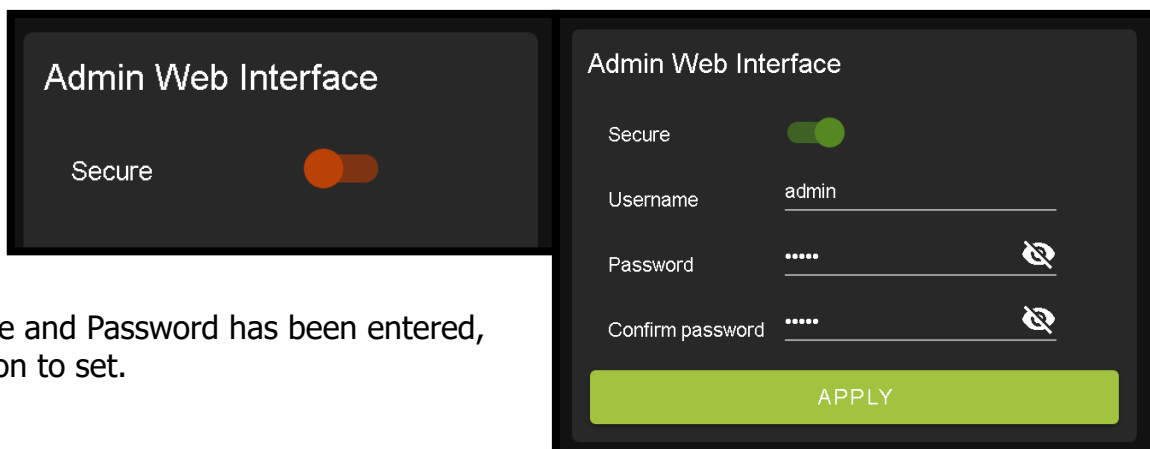

Once the desired Username and Password has been entered, click the green APPLY button to set.

With the Admin Web Interface enabled, the only menu that will be accessible using the WebUI will be the Matrix tab. The rest of the settings will require the Admin log in to access.

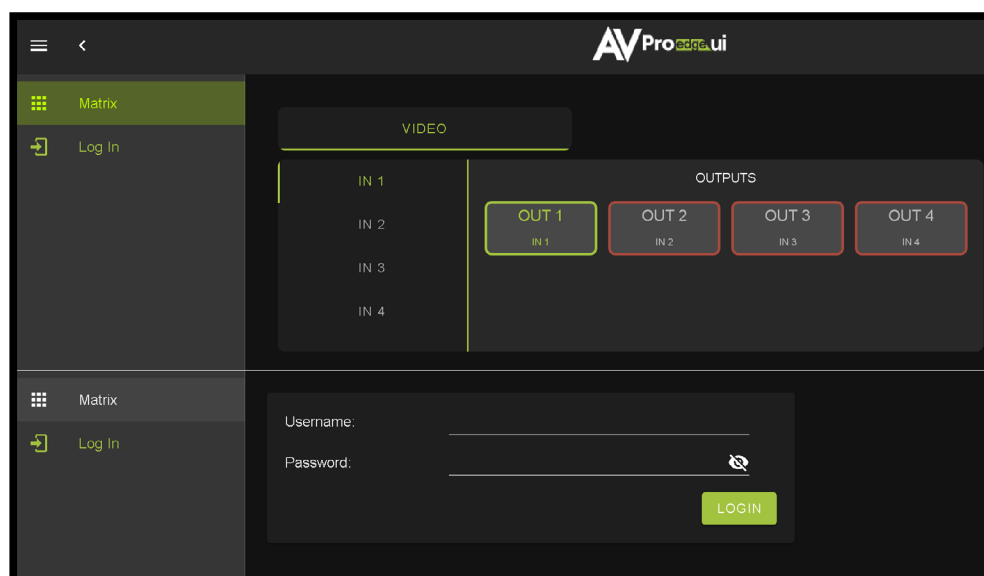

# WebUI: System - User Web Interface

This switch has two options, Red/Disabled (Default) and Green/Enabled. When enabled (green) there will be three fields that appear, Username, Password, and Confirm Password.

NOTE: The Admin Web Interface must first be Enabled and setup before this field will be available to change.

Default Username - user

Default Password - user123

Once the desired Username and Password has been entered, click the green APPLY button to set.

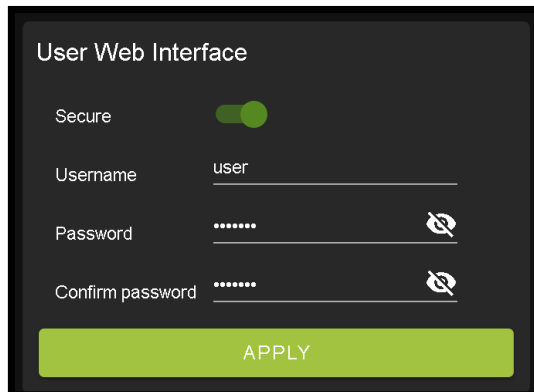

Note: The web page will reload to the Log In page.

With both Admin and User Web Interfaces enabled, no menus will be accessible using the WebUI without first logging in (see image below).

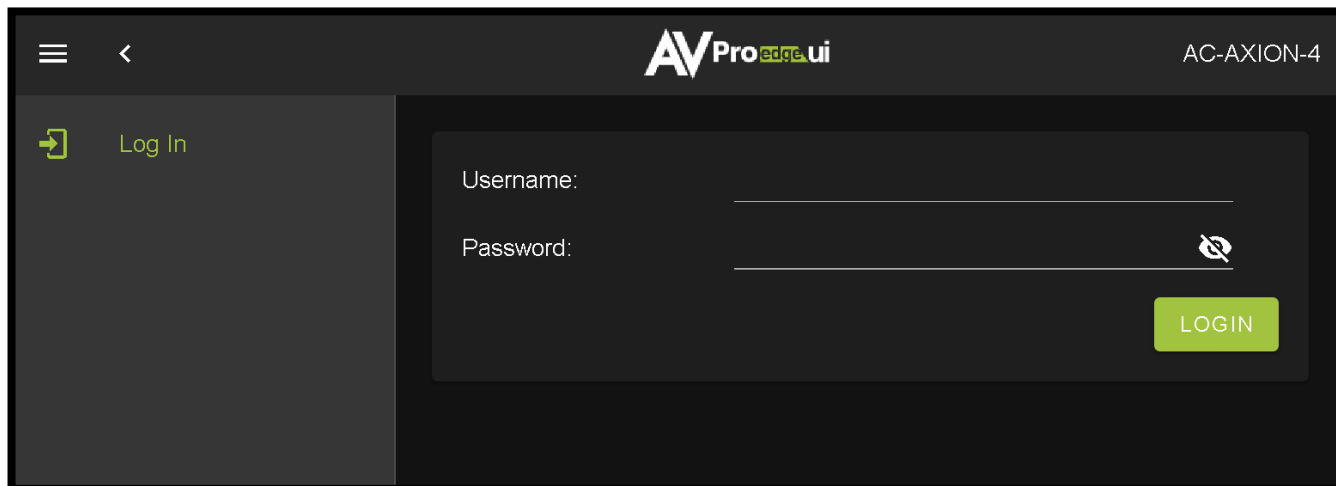

Logging in with the User credentials, the only menu that will be accessible will be the Matrix tab. The rest of the settings will require the Admin user to log in (see [page 24](#)).

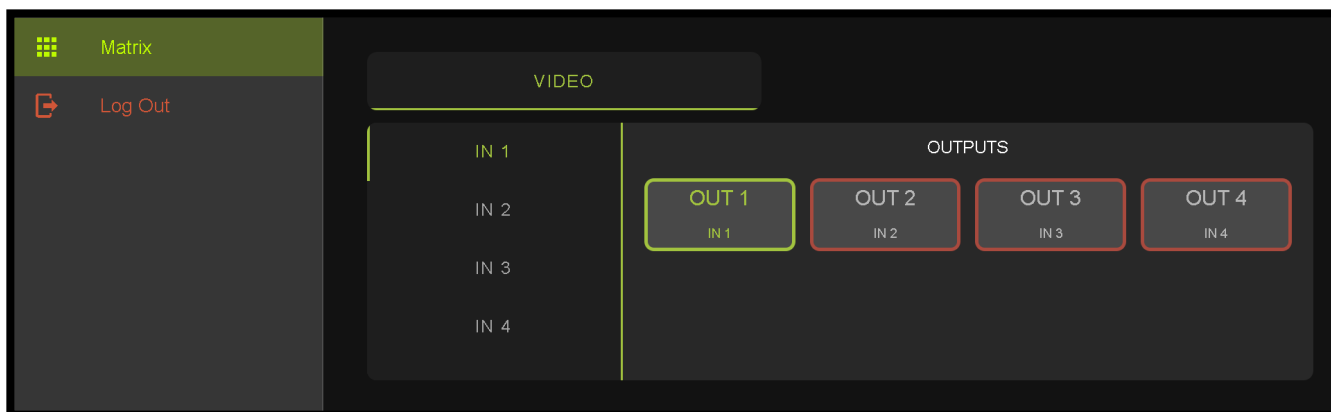

# WebUI: System - Cloud Services

By enabling Cloud Services your device will have the ability to connect to firmware servers for over-the-air (OTA) updates and enable third-party remote management services. If Cloud Services are disabled, your device will opt-out of any previously enabled services and will not be able to access OTA updates.

Before you can enable the cloud services you must first agree to the "Privacy Policy" and "Terms of Use".

You can view these documents by clicking on [Privacy Policy](#) or [Terms of Use](#) links, this will open up a PDF copy of that document in a new tab.

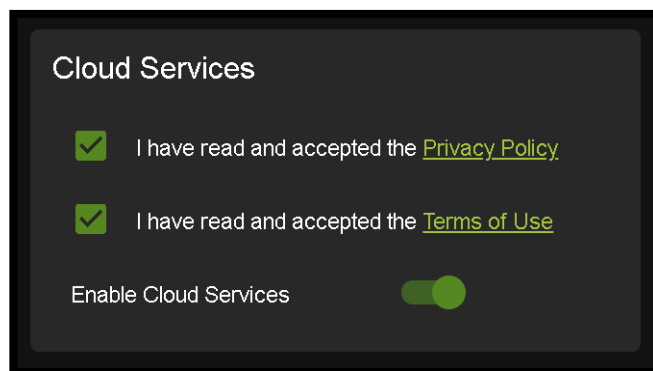
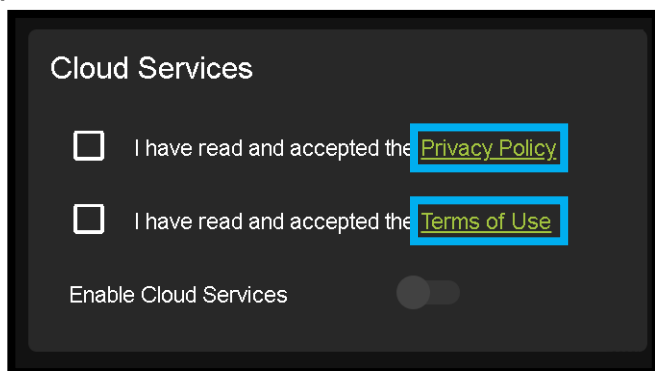

With the Cloud Services enabled you can use the System tab to check for new Firmware OTA (over the air).

This will check the firmware versions currently loaded on the AC-AXION-4 and compare to the latest available. If it is up to date, you will see a prompt stating "No update available!" click [CLOSE](#) to exit.

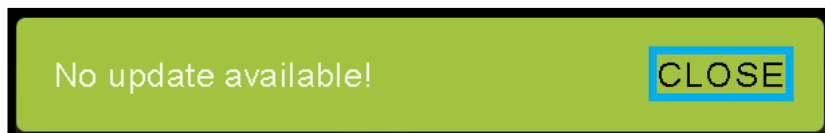

If an update is available, the following prompt will show. Simply click the [UPDATE](#) button to load.



**NOTE:** When loading firmware (depending on the firmware files that are being updated) some settings will revert back to Factory Defaults. Take note of the I/O Config tab. Settings like the INPUT/OUTPUT labels, EDID Settings, Video Scaling, Audio Settings, etc. as they will have to be re-applied after the firmware updates are completed.

If an update is available a file will automatically be selected, simply click the [UPLOAD](#) button to load the firmware files to the Matrix.

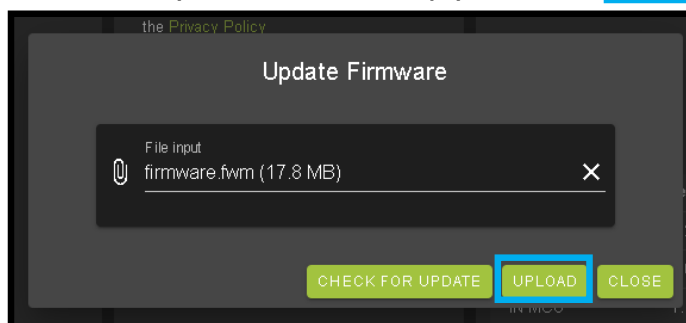

# WebUI: System - Firmware Update Cont.

Once the firmware file has been uploaded, it will display all containing firmware files. Here you can select individual firmware files to load or simply leave all files/options selected. If the version currently installed not newer, then that update will be skipped automatically.

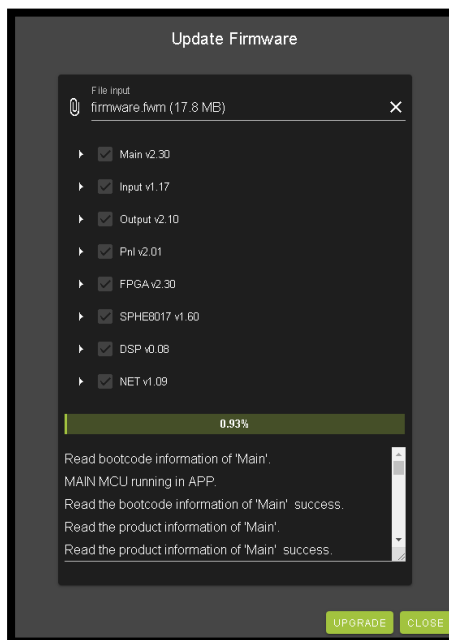
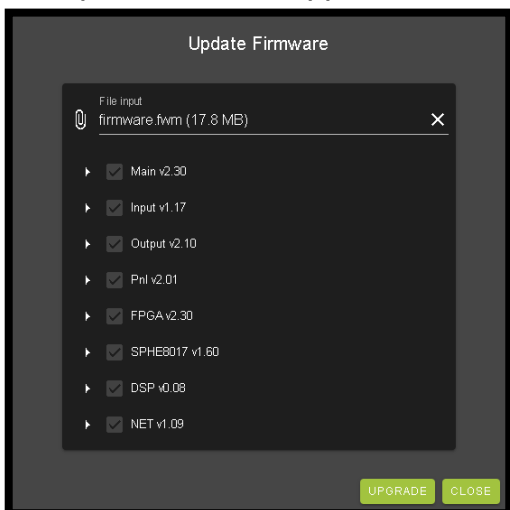

Once the progress bar hits 100% click the CLOSE button, the firmware upgrade process is complete.

Now you will want to go back and re-apply settings like INPUT/OUTPUT Labels, applied EDIDs, Video Scaler Settings, Audio Settings, etc.

# WebUI: System - Hardware

**LCD Timeout** - This adjusts the time the front panel display will stay lit up when a button is pressed.

There are four setting available

1. Always on (Default)
2. 15 Seconds
3. 30 Seconds
4. 45 Seconds

**Keypad Lock** - Enable or Disable (default) the front panel Keypad Lock.

**MCU/Version** - Lists the current Firmware Versions

**UPDATE FIRMWARE** - Check/upload firmware.

**FACTORY RESET** - Restores matrix to Factory Defaults

**REBOOT** - Reboots the AC-AXION-4

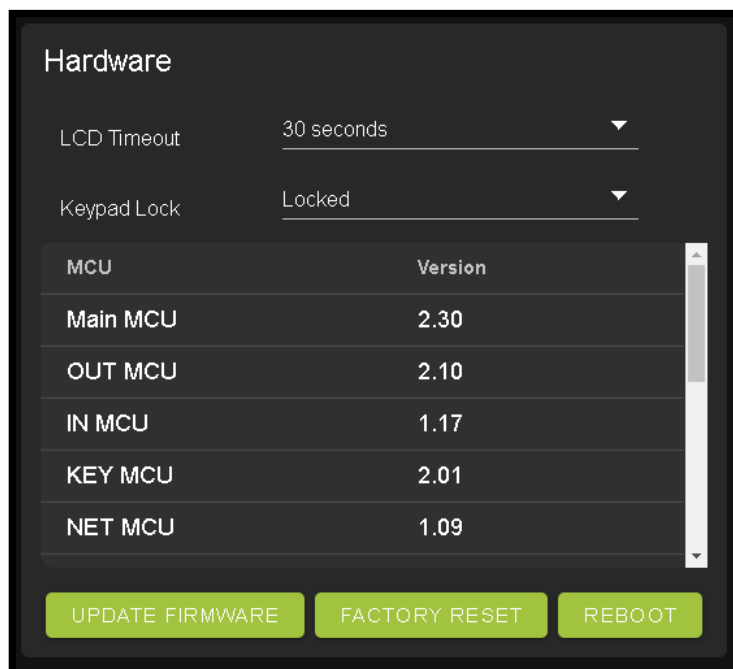

# WebUI: Diagnostics - HDMI IN

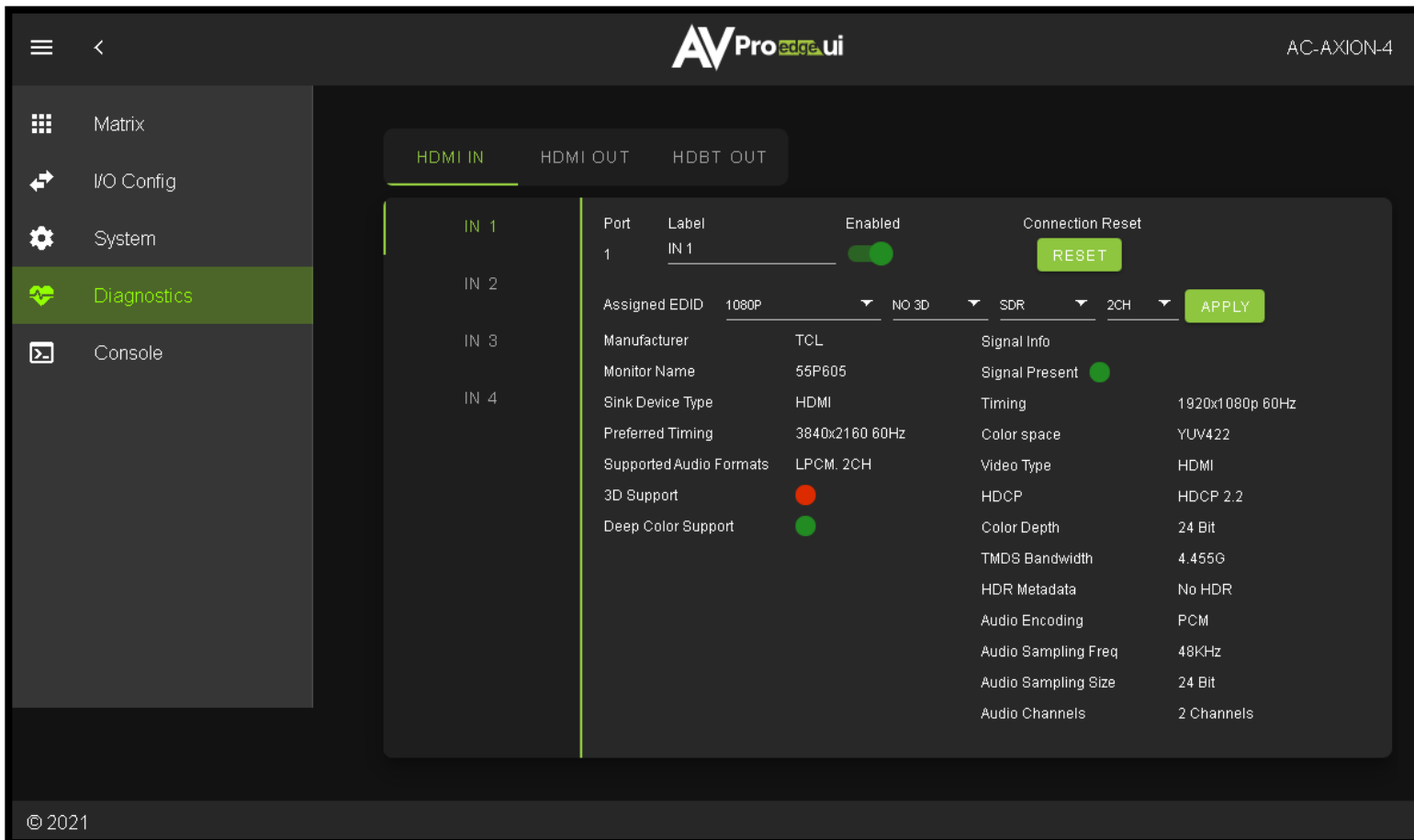

**Input Settings Label** - Use this to give an name/alias to your inputs (Apple TV, Cable Box, Roku, etc). Note: There is a 15 character limit to this field, the name will replace the default "IN #" throughout the rest of the WebUI (for instance the Video Matrix tab).

**Input Settings Enable switch** - Use this enable/disable switch to turn the corresponding Input port on or off. The default setting is enabled (green) by default.

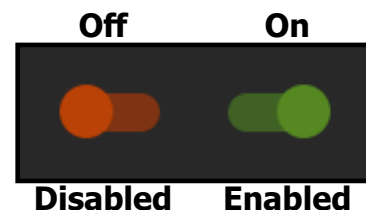

**Connection Reset** - Use this button to perform a reset of the HDMI Input connection.

**Input Settings EDID** - Use these four drop-downs to select your preferred EDID. The available combinations are as follows.

- |                   |                        |                        |                            |
|-------------------|------------------------|------------------------|----------------------------|
| 1. 1080P_2 CH     | 9. 4K30HZ_3D_8CH       | 17. 1080P_6CH_HDR      | 25. 4K60HzY420_3D_2 CH_HDR |
| 2. 1080P_6CH      | 10. 4K60HzY420_3D_2 CH | 18. 1080P_8CH_HDR      | 26. 4K60HzY420_3D_6CH_HDR  |
| 3. 1080P_8CH      | 11. 4K60HzY420_3D_6CH  | 19. 1080P_3D_2 CH_HDR  | 27. 4K60HzY420_3D_8CH_HDR  |
| 4. 1080P_3D_2 CH  | 12. 4K60HzY420_3D_8CH  | 20. 1080P_3D_6CH_HDR   | 28. 4K60HZ_3D_2 CH_HDR     |
| 5. 1080P_3D_6CH   | 13. 4K60HZ_3D_2 CH     | 21. 1080P_3D_8CH_HDR   | 29. 4K60HZ_3D_6CH_HDR      |
| 6. 1080P_3D_8CH   | 14. 4K60HZ_3D_6CH      | 22. 4K30HZ_3D_2 CH_HDR | 30. 4K60HZ_3D_8CH_HDR      |
| 7. 4K30HZ_3D_2 CH | 15. 4K60HZ_3D_8CH      | 23. 4K30HZ_3D_6CH_HDR  |                            |
| 8. 4K30HZ_3D_6CH  | 16. 1080P_2 CH_HDR     | 24. 4K30HZ_3D_8CH_HDR  |                            |

# WebUI: Diagnostics - HDMI IN Cont.

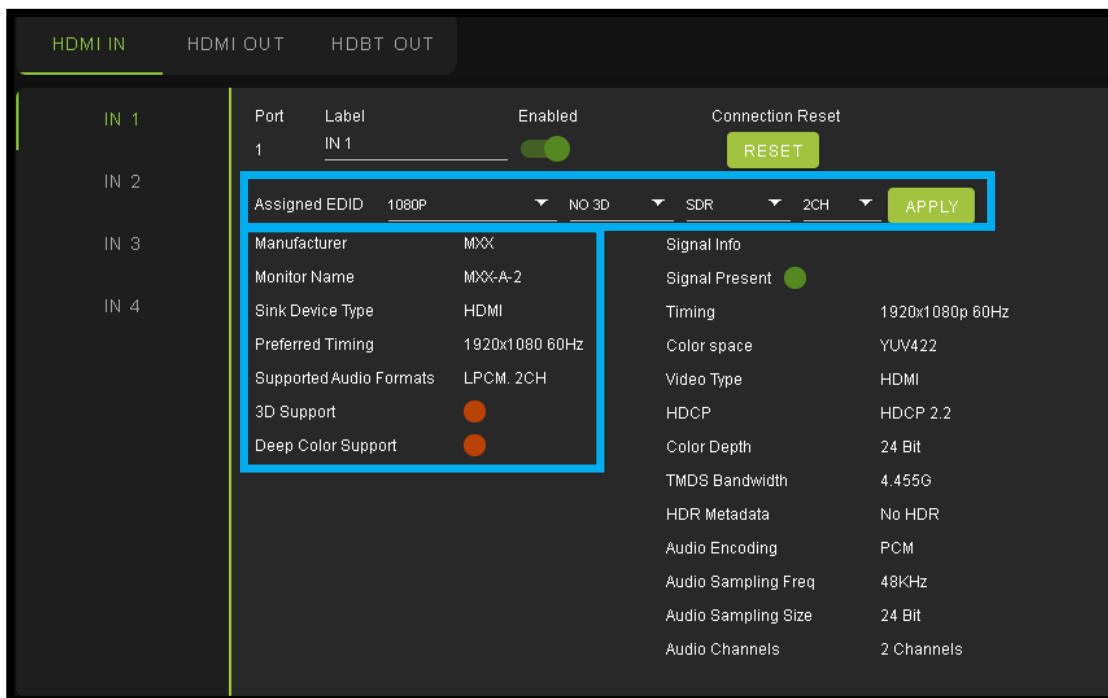

On the left, you will see the current applied EDID information. In the example above, you will see a canned 1080P - No 3D - SDR - 2 CH EDID applied to IN 1. Any EDID change, once applied will display here.

Signal Info shows the connected source's current output information. This includes

- Timing
- Color Space
- Video Type
- HDCP Version
- TMD5 Bandwidth
- HDR Metadata
- Audio Sampling Frequency
- Audio Sampling Size
- Audio Channels

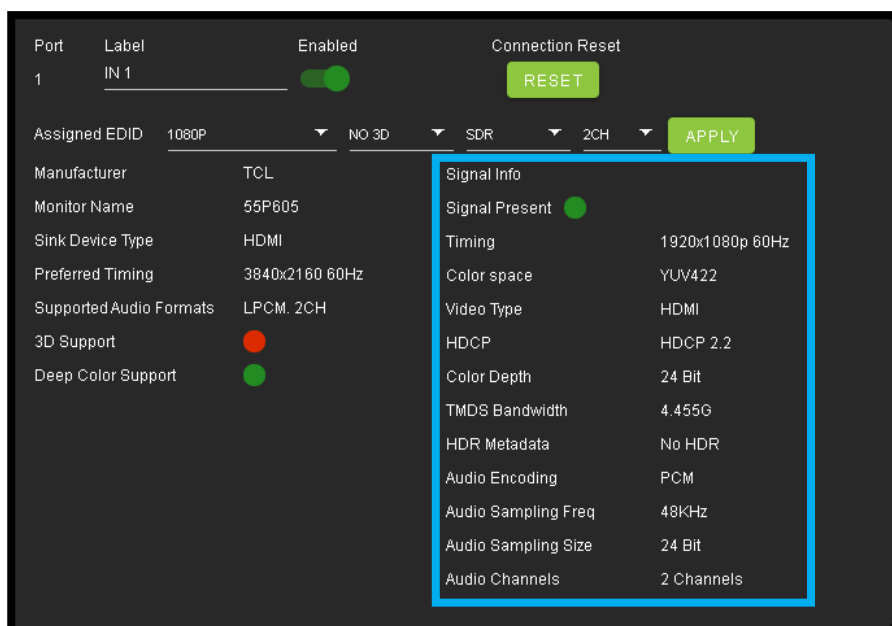

# WebUI: Diagnostics - HDMI OUT

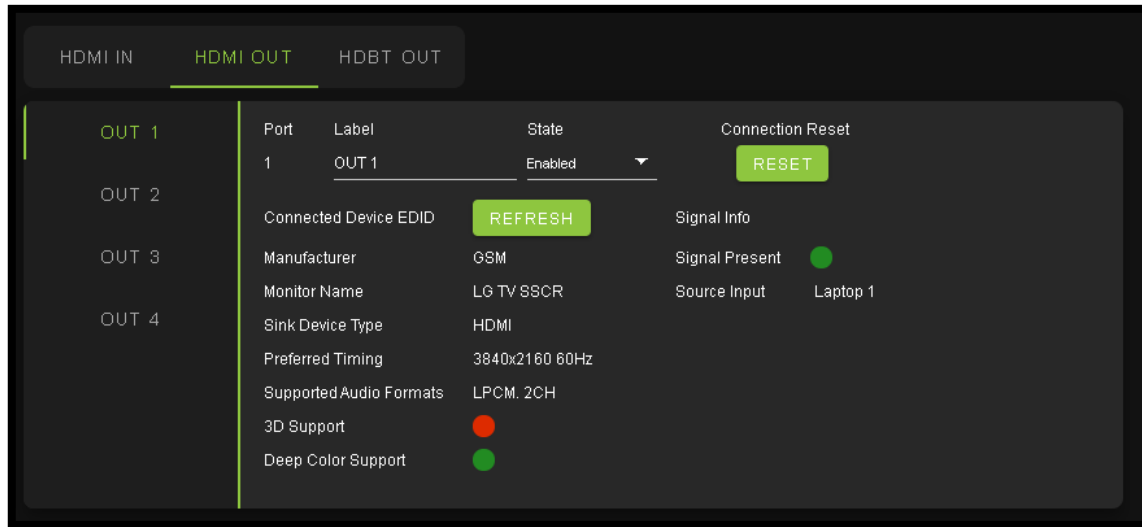

HDMI Output Label, State, and Connection Reset.

Connected Device EDID shows the connected sync's preferred EDID information and current state.

This includes

- Manufacturer
- Monitor Name
- Sink Device Type
- Preferred Timing
- Supported Audio Formats
- 3d Support
- Deep Color Support
- Signal Present
- Source Input

# WebUI: Diagnostics - HDBT OUT

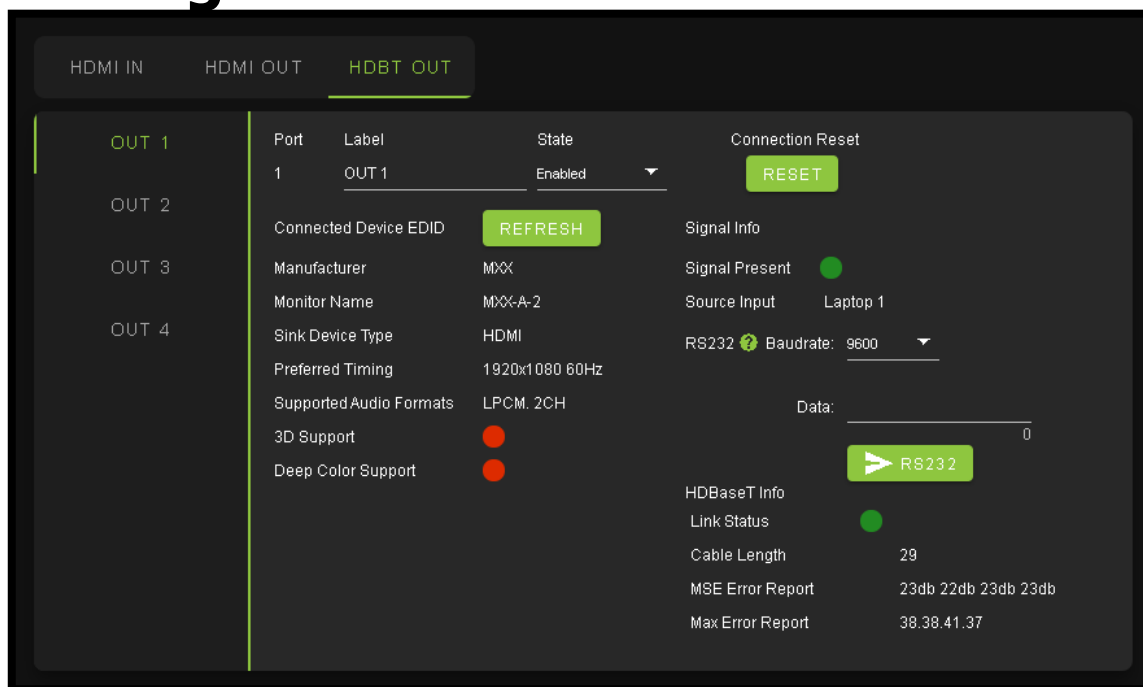

HDBaseT Output Label, State, and Connection Reset.

Connected Device EDID shows the connected sync's preferred EDID information and current state.

This includes a REFRESH button and the following EDID information:

- Manufacturer
- Monitor Name
- Sink Device Type
- Preferred Timing
- Supported Audio Formats
- 3d Support
- Deep Color Support

## Signal Info

- Signal Present Indicator Light (green - PRESENT / red - NOT present)
- Source Input (future update)
- RS232 Baudrate: Drop-down for changing RS232 Baudrate
- Data - Send RS232 over HDBaseT line to HDBaseT Receiver (Rx)

# WebUI: Diagnostics - HDBT OUT Cont.

## HDBaseT Info

- Link Status Indicator Light (there are 3 states)
  - a. Green - Link quality is good (within HDBaseT threshold)
  - b. Yellow - Link quality between the matrix and HDBaseT Receiver is marginal. You may experience occasional failures like dropouts/screen flashing/or no video.
  - c. Red - Exceeds the HDBaseT Error threshold, may experience frequent failures or no signal at all.
- Cable Length - In Meters (<20 indicates the cable is Less than 20 Meters)
- MSE Error Report - Shows error rate (in decibels) for each pair of wires
- Max Error Report - Shows Max error for each pair of wires

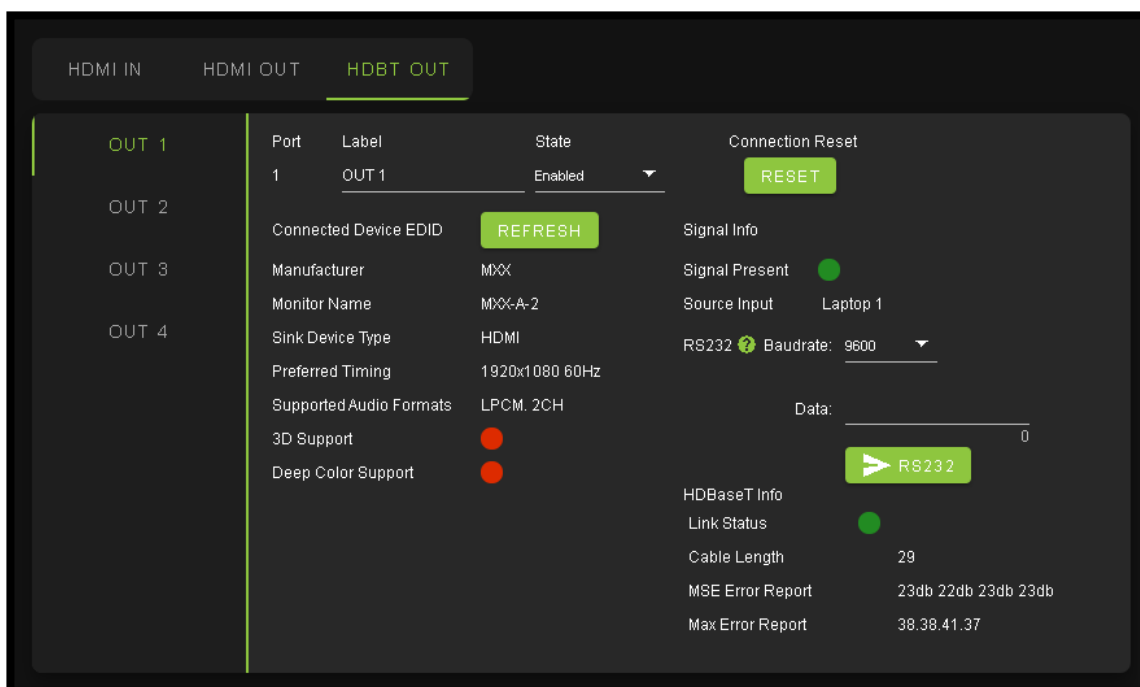

OUT 1	Port	Label	State	Connection Reset
OUT 1	1	OUT 1	Enabled	RESET
OUT 2				
OUT 3				
OUT 4				

Connected Device EDID	REFRESH	Signal Info
Manufacturer	MXX	Signal Present <span style="color: green;">●</span>
Monitor Name	MXX-A-2	Source Input Laptop 1
Sink Device Type	HDMI	RS232 <span style="color: green;">?</span> Baudrate: 9600
Preferred Timing	1920x1080 60Hz	Data: _____
Supported Audio Formats	LPCM. 2CH	
3D Support	<span style="color: red;">●</span>	
Deep Color Support	<span style="color: red;">●</span>	
		<span style="color: green;">▶</span> RS232
HDBaseT Info		
Link Status	<span style="color: green;">●</span>	
Cable Length	29	
MSE Error Report	23db 22db 23db 23db	
Max Error Report	38.38.41.37	

# WebUI: Console

There is a built in Command Console

Using the command API (command list) you can send device specific commands or use as a live monitor while sending commands from a control system (helpful in troubleshooting).

## Example

1. Click in the white box and type
  - a. GET STA

Click the green arrow or hit ENTER/RETURN on your keyboard

The the command response will show in the field below.

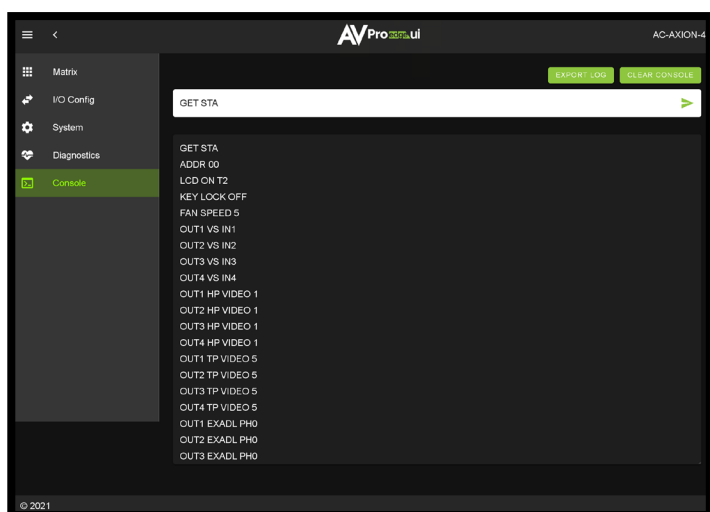
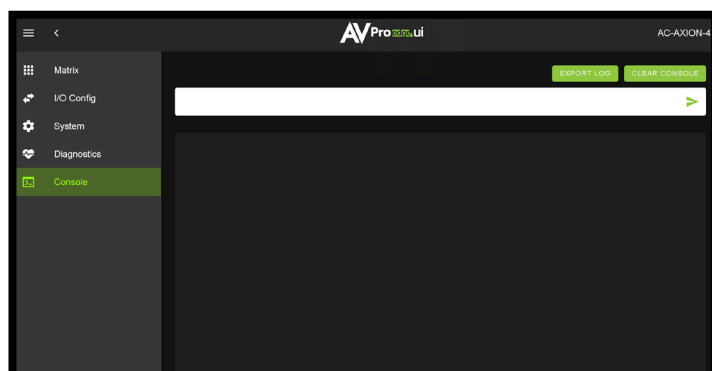

**Example - "GET STA"**  
Get status

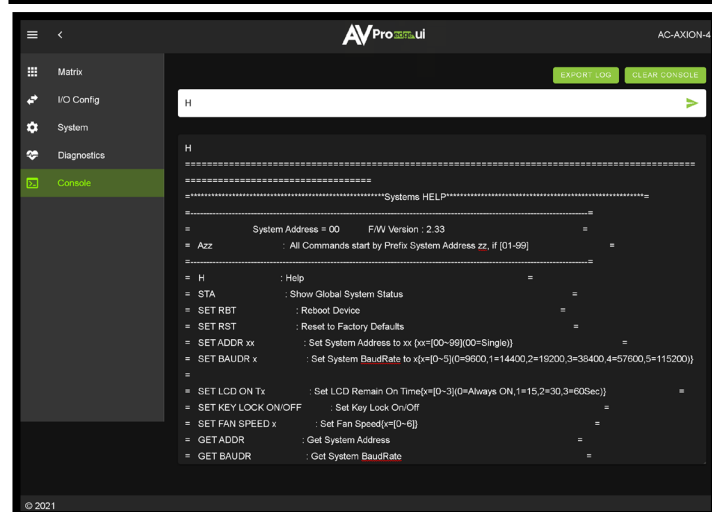

**Example - "H"**  
Help command  
Returns all Available Commands

## \*NEW to NET MCU Firmware Version 1.18

### EXPORT LOG - Button

This button will generate a text file containing the console information in your web browsers download folder.



### CLEAR CONSOLE - Button

This button will clear the current console session.

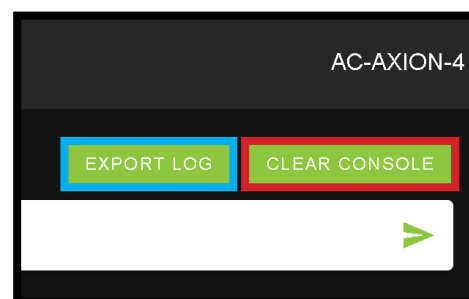

# Front Panel Control - Switching

The AC-AXION-4 can be switched from the front panel by first pressing the desired OUTPUT (bottom row) button first, then by pressing the desired INPUT button (top row).

1. Press the OUTPUT button (1 through 4) on the bottom row that corresponds with the OUTPUT (Display, or Sink Device) you would like to send to a source.
2. Once pressed, the front panel display will change to the SWITCH menu showing the current IN/OUT routes. Press the corresponding OUTPUT button (top row) to set.



You can also use the arrow keys and navigate to SWITCH on the front screen display.

1. Use the left/right arrows to select the OUTPUT press the OK button (the selection will turn red).
2. With the selection now red press the desired OUTPUT button (1-4) that you want to route to that INPUT.



# Front Panel Control - EDID

This matrix has 29 factory defined EDID settings. It also has 3 user defined EDID memories. The user EDID memories are independent to each input and can be set differently. The user defined EDID can be uploaded using the Axion WebUI or RS-232. In addition, you can choose to read the EDID from the desired output and the captured EDID will automatically store and overwrite the EDID in "USER EDID 1" and will be applied to the selected source.

- Use the arrow keys to highlight EDID then press OK to enter the EDID management menu.



- Use the Left/Right arrow to select one of the 4 INPUTS, and press OK.
- The EDID Status will turn red, now you can use the UP/DOWN arrows to change the EDID.
- Once the desired EDID is selected, press the OK button to set.

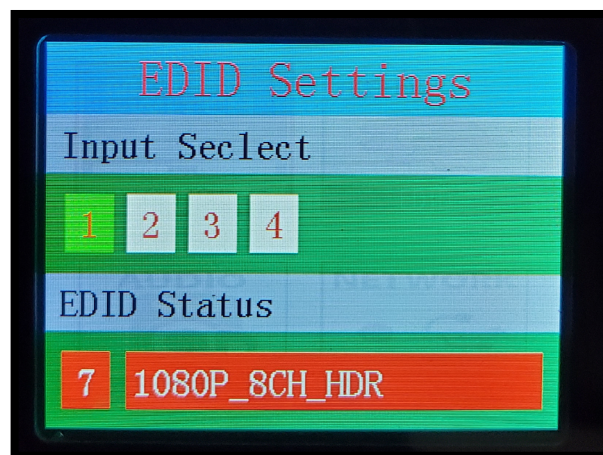
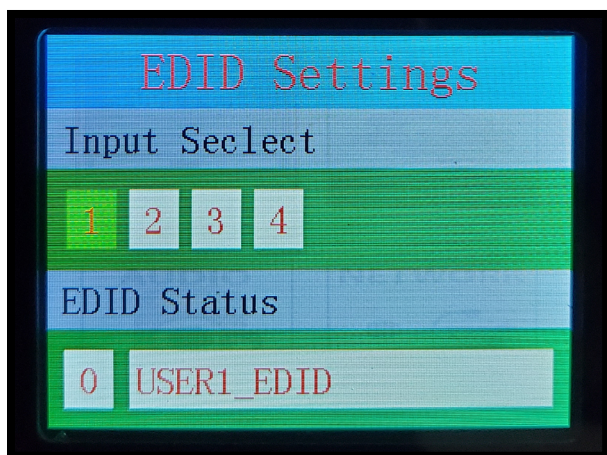

NOTE: See pages 35/43 for full EDID list

**In order to obtain Dolby Atmos, DTS:X, or other HBR Surround formats, the EDID must be copied from a capable device.**

# Front Panel Control - Audio

Once in "Matrix" mode for audio, the extracted audio routing on the AC-AXION-4 can be controlled from the front panel:

To Control:

1. Navigate to the Audio Menu.
2. Use the arrow key to highlight "Audio Mode" and press OK to select. The field will turn red.
3. Use up/down arrow keys to change to "Matrix".
4. Press the OK button again to set.
5. With the Audio Mode set to Matrix, you can use the INPUT/OUTPUT Buttons to route the audio. Press OUTPUT number first, then the INPUT number next.

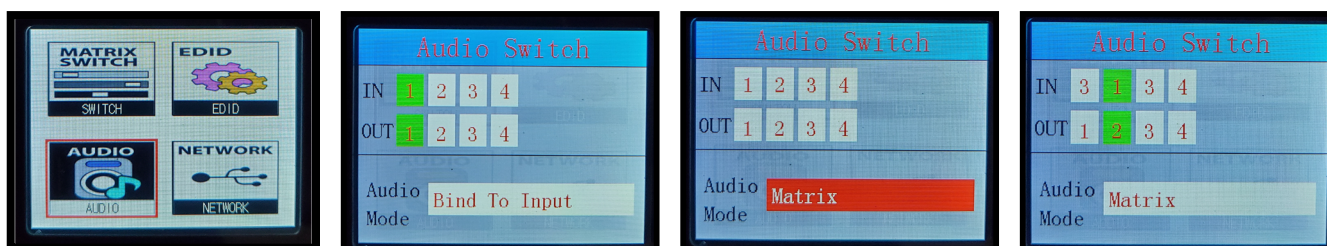

# Front Panel Control - Network

This menu displays the current Network information. You can edit the following Network settings from the front panel.

- RIP
- HIP
- MASK
- TCP/IP
- DHCP

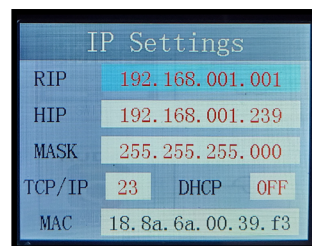
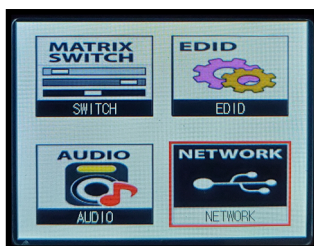

NOTE: The MAC Address is only viewable, you can not edit.

To change a setting:

1. Use the up/down arrow keys to highlight the setting you would like changed and press OK to select. The field will turn green.
2. Use up/down/left/right arrow keys to change the value.
3. Press the OK button again to set.

# Front Panel Control - IR Remote:



IR WINDOW

## IR Remote Control:

When routing HDMI, the matrix can be controlled by using the IR remote supplied with the product (battery not included, requires CR2025).

The labels on the right are the **OUTPUT** numbers.

The left arrow button decrements to the next input port, and the right arrow increments to the next input port.

The numbers are for selecting a desired **INPUT**.



\*Not Included

## IR Control: Switch

The IR IN ports on the back can accept an IR Receiving Eye (EYE) or a direct connection from a control system (I-PASS). There is a toggle switch to change between the two.

NOTE: If you are having any issues, verify the switch is properly set. To verify toggle from your desired setting, to the other setting, and then back to your desired setting.

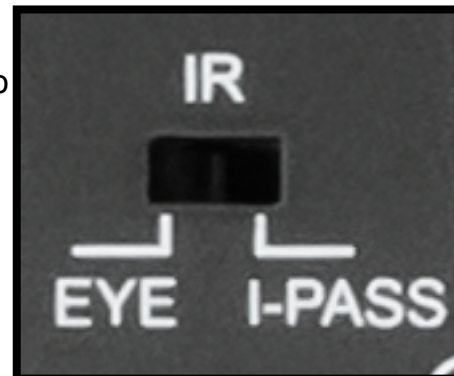

IR Receiving Eye - Set the switch to "EYE" to utilize a 3.5mm IR receiving eye.



Direct connection to a control system - Set the switch to "I-PASS" to connect directly to a control system.



## IR CONNECTION DIAGRAM

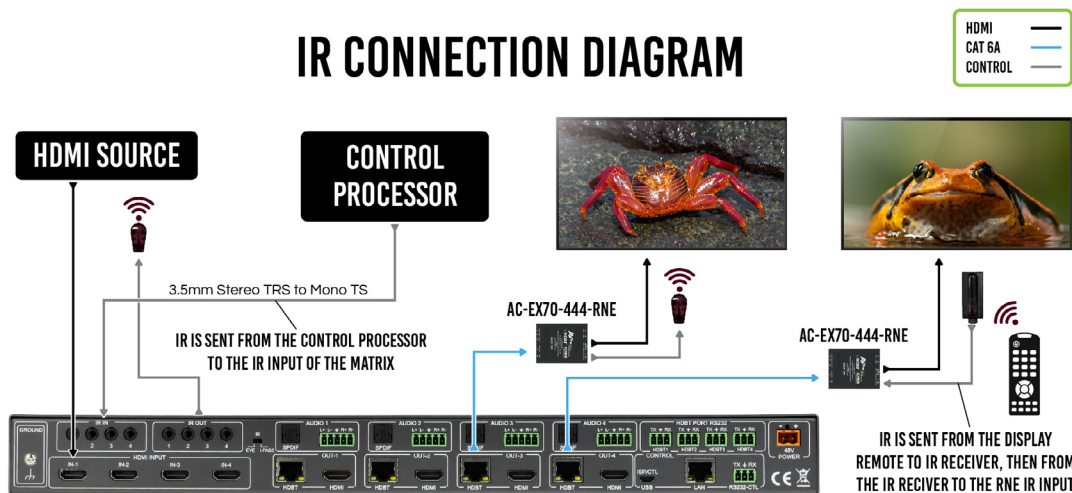

### IR NOTES (On the Matrix):

1. By default the IR IN is routed to the corresponding HDBaseT Output number (ie. IR IN #1 --> HDBaseT Output 1, IR IN #2 --> HDBaseT Output 2, etc...)
2. By default the IR OUT is automatically routed with the active source (ie. If you are watching INPUT 3 on HDBaseT OUTPUT 1, when you point a remote at an IR Receiver on the HDBaseT Rx connected the signal will be routed to IR OUT 3)
3. Each IR IN can be routed in any way you like (One to one or one to many) by using the command SET IRC EXT SW x1.x2.x3.x4 (See below).
4. Each IR OUT can be routed manually as well using the command SET IRC OUTx VS INy. This can also be controlled by the Web Interface

### IR NOTES (On the HDBaseT Receiver):

1. IR OUT = IR Emitter for sending signals to a Display or Projector (Note - Use Provided Emitters)
2. IR IN = For sending IR signals back to the Matrix for switching AND to send IR signals to the IR OUT on the Matrix - by default the IR OUT on the matrix is automatically routed with the active source (ie. If you are watching INPUT 3 on HDBaseT OUTPUT 1, when you point a remote at an IR Receiver on the HDBaseT Rx connected the signal will be routed to IR OUT 3)

# RS-232 and TCP/IP Control:

The AC-AXION-4 can be controlled with either RS-232 or TCP/IP commands. Certain switching or format configurations can only be done using these commands. We recommend using either the MyUART (RS-232 - free) or Hercules (TCP/IP - free) apps as they are very easy to use for sending commands to the machine.

For TCP/IP control commands use Telnet Port 23.

For RS-232, use a null modem serial cable adapter and set the serial communications to: 57600,n,8,1 (baud: 57600, no parity, 8 data bits and 1 stop bit) with no handshaking.

Please add a return (Enter key) after each command when using direct commands.

The unified command list (ASCII) is listed on the following pages. Text version available [here](#), and under the resources tab of on the products [web page](#).

## USB CONTROL FOR AVPRO EDGE

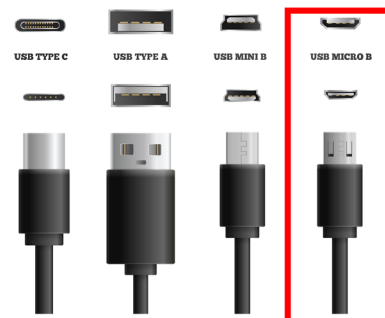
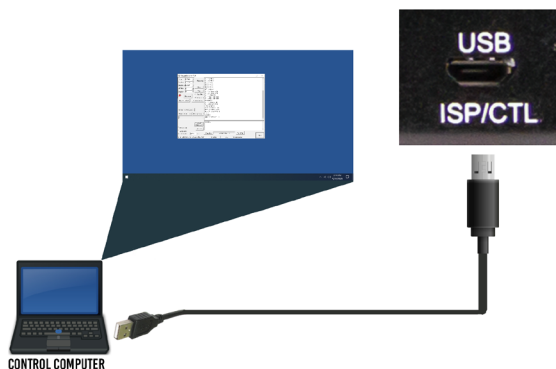
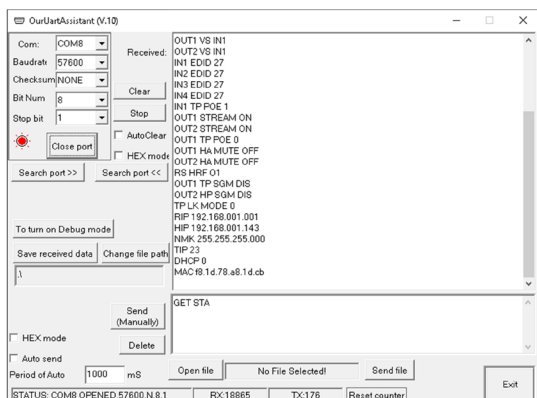

[WWW.AVPROEDGE.COM/DRIVERS](http://WWW.AVPROEDGE.COM/DRIVERS)

**OTHER TOOLS & DRIVERS**

**MyUart Serial Communicator:** Used to send direct serial commands to our products.

**Universal FTDI USB->Serial Driver:** Used with SDX-G/SDX-A & Fox & Hound and several USB-Serial converters supplied by AVPro Edge

## RS-232 CABLE FOR AVPRO EDGE

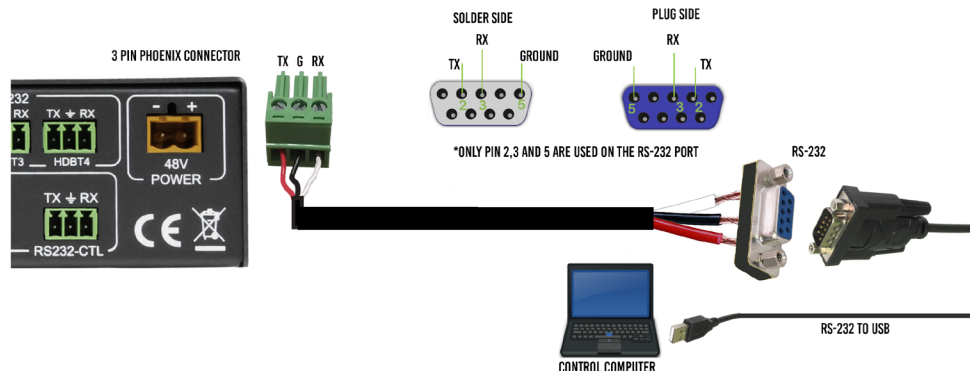

# HDBaseT lights: LINK

These ports are HDBaseT Transmitters (TX) and are designed to be connected via a Category cable (Cat6 or better) to an HDBaseT Receiver (RX).

**NOTE:** Non AVPro HDBaseT Receivers may work but ICT (our Invisible Compression Technology) will not. This means higher bandwidth signals (greater than 10.2Gbps) will not pass as this requires ICT. See Bandwidth chart on Page 50.

**LINK** - Above RJ45 (HDBT) Port: **(Green)** This indicator shows that the AV HDBT link between the Tx and Rx is in tact. This light should **ALWAYS** be **SOLID**.

If this light is flashing or not present attempt following:

1. Check the length. The maximum distances are 70m (230ft) on 4K and 100m (330ft) on 1080P.
2. Remove any coils of cable and make sure that there is not excess cabling.
3. Bypass all patch panels and punch-down blocks.
4. Re-terminate connectors. Sometimes, even if a cable tester indicates the run is valid, something may be slightly off.
  - a. Standard RJ45 ends are recommended. Pass through style types can cause interference/crosstalk
5. Contact AVProEdge if these suggestions do not work.

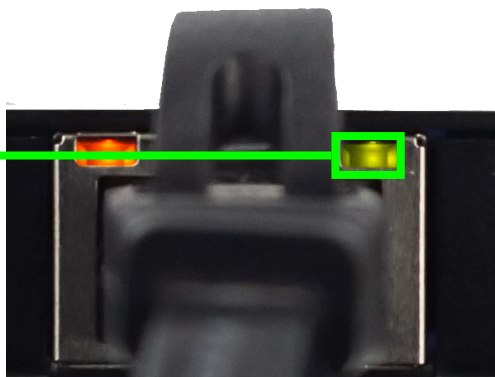
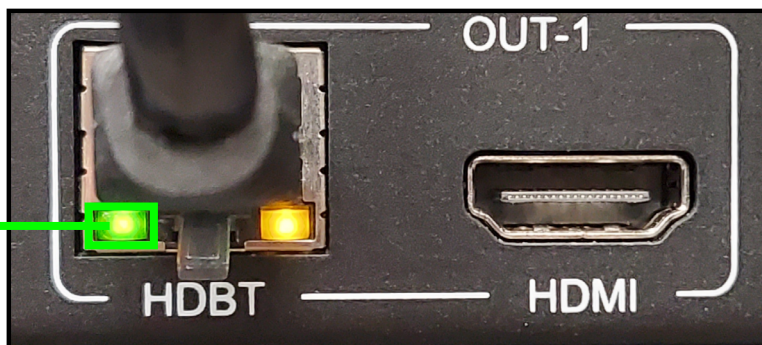

AVProEdge - HDBaseT Extender  
Indicator Lights

# HDBaseT lights: STATUS

**STATUS** - Above RJ45 (HDBT) Port: **(Amber)** This is an indicator showing that the power is present between the Transmitter and Receiver. This light **ALWAYS BLINKS** steadily indicating everything is OK.

If this light is flashing or not present attempt following:

1. Check the length. The maximum distances are 70m (230ft) on 4K and 100m (330ft) on 1080P.
2. Remove any coils of cable and make sure that there is not excess cabling.
3. Bypass all patch panels and punch-down blocks.
4. Re-terminate connectors. Sometimes, even if a cable tester indicates the run is valid, something may be just slightly off.
5. Standard RJ45 ends are recommended. Pass through style types can cause interference/crosstalk
6. Try powering from the Receiver instead of the Transmitter (See Receiver page for more about PoE direction).
7. Contact AVProEdge if these steps do not work.

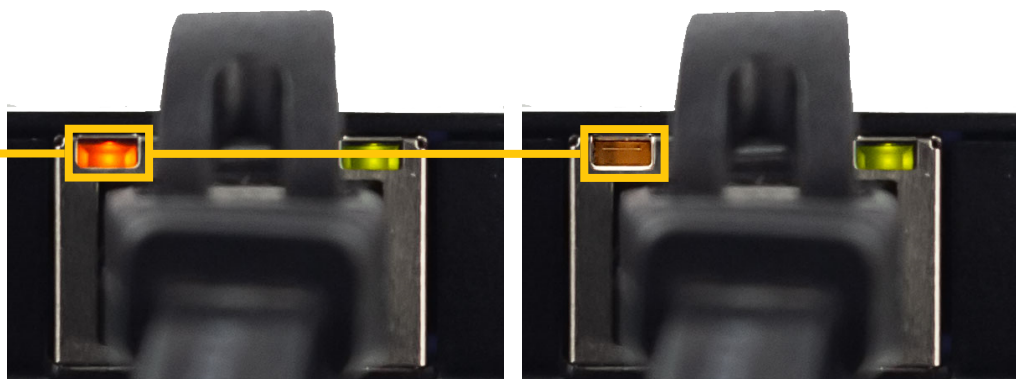
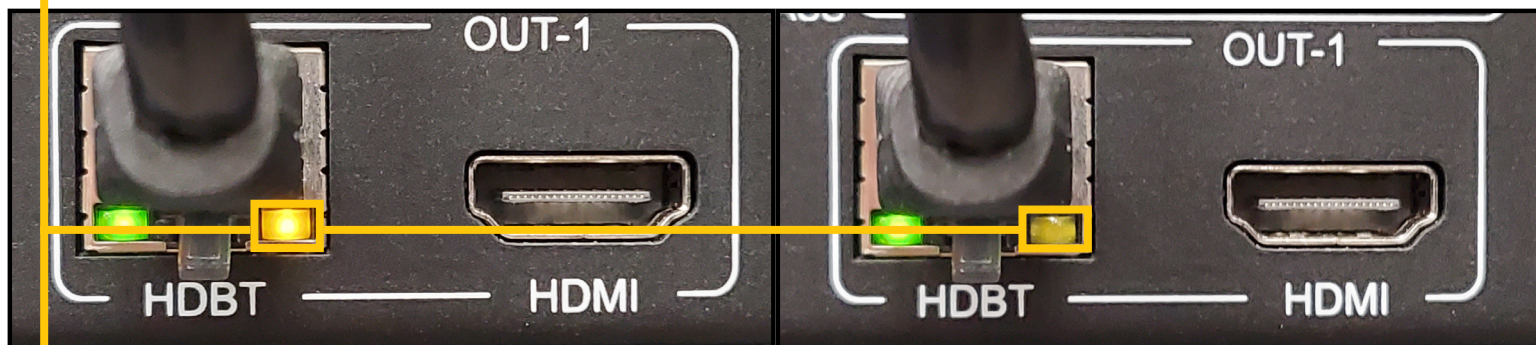

AVProEdge - HDBaseT Extender  
Indicator Lights

# Command List:

- Baudrate: 57600
- Checksum: None
- Bit Num: 8
- Stop Bit: 1

Command	Action
H	: Help
STA	: Show Global System Status
SET RBT	: Reboot Device
SET RST	: Reset to Factory Defaults
SET ADDR xx	: Set System Address to xx {xx=[00-99](00=Single)}
SET BAUDR x	: Set System BaudRate to x {x=[0~5](0=9600,1=14400,2=19200,3=38400,4=57600,5=115200)}
SET LCD ON Tx	: Set LCD Remain On Time{x=[0~3](0=Always ON,1=15,2=30,3=60Sec)}
SET KEY LOCK ON/OFF	: Set Key Lock On/Off
SET FAN SPEED x	: Set Fan Speed{x=[0~6]}
GET ADDR	: Get System Address
GET BAUDR	: Get System BaudRate
GET STA	: Get System Status
GET FAN SPEED	: Get Fan Speed Value
GET INx SIG STA	: Get Input x Signal Status{x=[0~4](0=ALL)}
GET OUTx SIG STA	: Get Output x Signal Status{x=[0~4](0=ALL)}
GET INx AUD FMT INF	: Get Input x Audio information{x=[0~4](0=ALL)}
GET INx VID FMT INF	: Get Input x Video information{x=[0~4](0=ALL)}
GET OUTx HP HPD	: Get HDMI Output x HPD Status{x=[0~4](0=ALL)}
GET OUTx TP HPD	: Get HDBT Output x HPD Status{x=[0~4](0=ALL)}
GET LCD ON T	: Get LCD Remain On Time
GET KEY LOCK	: Get Key Lock Status

## Output Setup Commands:

SET OUTx VS INy	: Set Output x To Input y{x=[0~4](0=ALL), y=[1~4]}
SET OUTx HP VIDEOy	: Set HDMI Output VIDEO Mode {x=[0~4](0=ALL), y=[1,3](1=BYPASS,3=2K->4K)}
SET OUTx TP VIDEOy	: Set HDBT Output VIDEO Mode {x=[0~4](0=ALL), y=[2,5](2=4K->2K,5=ICT Mode)}
SET OUTx EXAUD LEVy	: Set Output x Ex-Audio(Balanced) Volume Levely{x=[0~4](0=ALL),y=[0~100]}
SET OUTx EXA LVLy	: Set Output x Ex-Audio(Balanced) Left Volume Levely{x=[0~4](0=ALL),y=[0~10]}
SET OUTx EXA RVLy	: Set Output x Ex-Audio(Balanced) Right Volume Levely{x=[0~4](0=ALL),y=[0~10]}
SET OUTx EXEQ MODEy	: Set Output x EX-Audio Volume EQ Modey{x=[0~4](0=ALL),y=[0~7]: y=[0-OFF],[1-Classical],[2-Headphone],[3-Hall],[4-Live],[5-Pop],[6-Rock],[7-Vocal]}
SET OUTx EXA EN/DIS	: Set Ex-Audio Output Enable/Disable{x=[0~4](0=ALL)}
SET OUTx EXADL PHY	: Set Ex-Audio Delay {x=[0~4](0=ALL), y=[0~7](0=Bypass,1~7=90,180,270,360,450,540,630MS)}
SET EXAMX MODEx	: Set Ex-Audio Matrix Mode{x=[0~2](0=Bind To Output,1=Bind To Input,2=Matrix)}
SET OUTx AS INy	: Set Ex-Audio Output x To Input y{x=[0~4](0=ALL), y=[1~4]}
SET OUTx HP SGM EN/DIS	: Set HDMI Output Signal Generator Enable/Disable{x=[0~4](0=ALL)}
SET OUTx TP SGM EN/DIS	: Set HDBT Output Signal Generator Enable/Disable{x=[0~4](0=ALL)}
SET OUTx HP STREAM ON/OFF	: Set HDMI Output x Stream ON/OFF{x=[0~4](0=ALL)}
SET OUTx TP STREAM ON/OFF	: Set HDBT Output x Stream ON/OFF{x=[0~4](0=ALL)}
SET OUTx HP HA MUTE ON/OFF	: Set HDMI Output x Audio Mute ON/OFF{x=[0~4](0=ALL)}
SET OUTx TP HA MUTE ON/OFF	: Set HDBT Output x Audio Mute ON/OFF{x=[0~4](0=ALL)}
SET OUTx LR MODE EN/DIS	: Set Output x Long Range Mode Enable/Disable{x=[0~4](0=ALL)}
SET OUTx TP POE y	: Set Output x POE Mode{x=[0~4](0=ALL),y=[0~1](0=Auto,1=Force)}

# Command List Continued:

GET OUTx VS	: Get Output x Video Route {x=[0~4]}(0=ALL)}
GET OUTx HP VIDEO	: Get HDMI Output x Video Mode{x=[0~4]}(0=ALL)}
GET OUTx TP VIDEO	: Get HDBT Output x Video Mode{x=[0~4]}(0=ALL)}
GET OUTx HP EDID DATA	: Get HDMI Output x EDID DATA{x=[1~4]}
GET OUTx TP EDID DATA	: Get HDBT Output x EDID DATA{x=[1~4]}
GET OUTx EXAUD LEV	: Get Output x Ex-Audio(Balanced) Volume Level{x=[0~4]}(0=all)}
GET OUTx EXA LVL	: Get Output x Ex-Audio(Balanced) Left Volume Level{x=[0~4]}(0=all)}
GET OUTx EXA RVL	: Get Output x Ex-Audio(Balanced) Right Volume Level{x=[0~4]}(0=all)}
GET OUTx EXA RLVL	: Get Output x Ex-Audio(Balanced) Right Left Volume Level{x=[0~4]}(0=all)}
GET OUTx EXEQ MODE	: Get Output x EX-Audio Volume EQ Mode Status{x=[0~4]}(0=ALL)}
GET OUTx EXA	: Get Ex-Audio Output Enable/Disable Status{x=[0~4]}(0=ALL)}
GET OUTx EXADL PH	: Get Ex-Audio Output Delay Status{x=[0~4]}(0=ALL)}
GET EXAMX MODE	: Get Ex-Audio Matrix Mode
GET OUTx AS	: Get Output x Ex-Audio Route{x=[0~4]}(0=ALL)}
GET OUTx HP SGM	: Get HDMI Output Signal Generator Enable/Disable Status{x=[0~4]}(0=ALL)}
GET OUTx TP SGM	: Get HDBT Output Signal Generator Enable/Disable Status{x=[0~4]}(0=ALL)}
GET OUTx HP STREAM	: Get HDMI Output x Stream ON/OFF Status{x=[0~4]}(0=ALL)}
GET OUTx TP STREAM	: Get HDBT Output x Stream ON/OFF Status{x=[0~4]}(0=ALL)}
GET OUTx HP HA MUTE	: Get HDMI Output x Audio Mute ON/OFF Status{x=[0~4]}(0=ALL)}
GET OUTx TP HA MUTE	: Get HDBT Output x Audio Mute ON/OFF Status{x=[0~4]}(0=ALL)}
GET OUTx LR MODE	: Get Output x Long Range Mode Status{x=[0~4]}(0=ALL)}
GET OUTx TP POE	: Get Output x POE Mode{x=[0~4]}(0=ALL)}
GET OUTx TP SGM	: Get HDBT Output Signal Generator Enable/Disable Status{x=[0~4]}(0=ALL)}
GET OUTx HP STREAM	: Get HDMI Output x Stream ON/OFF Status{x=[0~4]}(0=ALL)}
GET OUTx TP STREAM	: Get HDBT Output x Stream ON/OFF Status{x=[0~4]}(0=ALL)}
GET OUTx HP HA MUTE	: Get HDMI Output x Audio Mute ON/OFF Status{x=[0~4]}(0=ALL)}
GET OUTx TP HA MUTE	: Get Output x Long Range Mode Status{x=[0~4]}(0=ALL)}
GET OUTx LR MODE	: Get Output x Long Range Mode Status{x=[0~4]}(0=ALL)}
GET OUTx TP POE	: Get Output x POE Mode{x=[0~4]}(0=ALL)}

## Input Setup Commands:

SET INx EDID y	: Set Input x EDID{x=[0~4]}(0=ALL), y=[0~32]}		
0:1080P_2CH(PCM)	1:1080P_6CH	2:1080P_8CH	
3:1080P_3D_2CH(PCM)	4:1080P_3D_6CH	5:1080P_3D_8CH	
6:4k30Hz_3D_2CH(PCM)	7:4k30Hz_3D_6CH	8:4k30Hz_3D_8CH	
9:4K60Hz(Y420)_3D_2CH(PCM)	10:4K60Hz(Y420)_3D_6CH	11:4K60Hz(Y420)_3D_8CH	
12:4K60HZ_3D_2CH	13:4K60HZ_3D_6CH	14:4K60HZ_3D_8CH	
15:1080P_2CH(PCM)_HDR	16:1080P_6CH_HDR	17:1080P_8CH_HDR	
18:1080P_3D_2CH(PCM)_HDR	19:1080P_3D_6CH_HDR	20:1080P_3D_8CH_HDR	
21:4K30Hz_3D_2CH(PCM)_HDR	22:4K30Hz_3D_6CH_HDR	23:4K30Hz_3D_6CH_HDR	
24:4K60Hz(Y420)_3D_2CH(PCM)_HDR	25:4K60Hz(Y420)_3D_6CH_HDR	26:4K60Hz(Y420)_3D_8CH_HDR	
27:4K60Hz_3D_2CH(PCM)_HDR	28:4K60Hz_3D_6CH_HDR	29:4K60Hz_3D_8CH_HDR	
30:USER1_EDID	31:USER2_EDID	32:USER3_EDID	
SET INx EDID CY OUTy HP	: Copy HDMI Output y EDID To Input x(USER1 BUF){x=[0~4]}(0=ALL), y=[1~4]}		
SET INx EDID CY OUTy TP	: Copy HDBT Output y EDID To Input x(USER1 BUF){x=[0~4]}(0=ALL), y=[1~4]}		
SET INx EDID Uy DATAz	: Write EDID To User y Buffer of Input x{x=[0~4]}(0=ALL), y=[1~3],z=[EDID Data]}		
SET INx TMDS ON/OFF	: Set Input Port Power On/Off{x=[0~4]}(0=ALL)}		
SET INx EXMX MODEy	: SET Input x Ex-Audio Matrix Mode y{x=[0~4]}(0=ALL),y=Matrix Mode[0-7],Mode :[0-Matrix Mode :Close],[1-STD FX,Default Mode],[2-Low Center+],[3-Mid Center+],[4-High Center+],[5-Middle FX],[6-Full FX],[7-Voice FX]}		
GET INx EDID	: Get Input x EDID Index{x=[0~4]}(0=ALL)}		
GET INx EDID y DATA	: Get Input x EDID y Data{x=[1~4],y=[0~32]}		

# Command List Continued:

GET INx TMDS	: Get Input Port Power On/Off State{x=[0~4]}(0=ALL)}
GET INx EXMX MODE	: GET Input x Ex-Audio Matrix Mode Status{x=[0~4]}(0=ALL)}
<b>Network Setup Command:</b>	
	: ( xxx=[000-255], zzzz=[0001~9999]
SET RIP xxx.xxx.xxx.xxx	: Set Route IP Address to xxx.xxx.xxx.xxx
SET HIP xxx.xxx.xxx.xxx	: Set Host IP Address to xxx.xxx.xxx.xxx
SET NMK xxx.xxx.xxx.xxx	: Set Net Mask to xxx.xxx.xxx.xxx
SET TIP zzzz	: Set TCP/IP Port to zzzz
SET DHCP y	: Set DHCP {y=[0~1]}(0=Dis,1=Enable)}
GET RIP	: Get Route IP Address
GET HIP	: Get Host IP Address
GET NMK	: Get Net Mask
GET TIP	: Get TCP/IP Port
GET DHCP	: Get DHCP Status
GET MAC	: Get MAC Address
<b>IR Route Setup Command:</b>	
SET LIR EXT SW x1.x2.x3.x4	: Set IR Extender Switch{x1~x4=[0-1]}(0=Disable,1=Enable)}
SET CIR EXT SW x1.x2.x3.x4	: Set Callback IR Extender Switch{x1~x4=[0,1]}(0=Disable,1=Enable)}
GET LIR EXT SW	: Get IR Extender Switch Status
GET CIR EXT SW	: Get Callback IR Extender Switch Status
<b>RS232 Route Setup Command:</b>	
SET RS CHy MUX x1.x2.x3.x4.	: Set the RS232 MUX{y=[1-4],x1~x4=[0-1]}(0=Disable,1=Enable)}
SET RS PTH OUTx LENy BRz	: Set RS232 Pass Through to Outputx {x=[0-4]}(0=ALL),y=[1~100],z=[0~5]}(0=9600,1=14400,2=19200,3=38400,4=57600,5=115200)}
GET RS CHx MUX	: Get the RS232 MUX Status{x=[0~4]}(0=all)}
<b>IR Code Setup Command</b>	
SET IR SYS xx.yy	: Set IR Custom Code{xx=[00-FFH],yy=[00-FFH]}
SET IR OUTx Iny CODE zz	: Set IR Data Code{x=[1~4],y=[1~4],zz=[00-FFH]}
GET IR SYS	: Get IR Custom Code
GET IR OUTx Iny CODE	: Get IR Data Code

# Extracted Audio:

The extracted audio ports have three distinct operating modes. Your desired mode can be set to suite your particular installation.

The 3 modes are:

**Bind to Input** ~ This is the default configuration. In this mode the audio port number corresponds to the INPUT signal. This is ideal for systems where audio is matrixed separately in a zoned amplifier.

**Bind to Output** ~ This configuration will automatically have the audio follow OUTPUT, so the audio from the extracted port always matches the HDMI output. This is ideal for systems that use local AVR's for some of the zones.

**Independent/Matrix** ~ This mode allows you matrix the extracted audio outputs independent of HDMI. In this mode a new set of commands becomes available to be able to route audio however you want. This can be used as a separate zoned audio matrix with only using an amplifier.

## Setting up Extracted Audio Routing:

You can set up Extracted Audio Routing from the front panel, Web, Driver or by sending the following command:

SET EXAMX MODE $x$  -- Where  $\{x=[0\sim 2]\}$ (0=Bind To Output,1=Bind To Input,2=Matrix)

If you set to "Matrix" you can use the following command to route the 16 extracted audio ports to any INPUT:

SET OUT $x$  AS IN $y$  -- Where Set Ex-Audio Output  $x$  To Input  $y$   $\{x=[0\sim 4]\}$ (0=ALL),  $y=[1\sim 4]\}$

**Balanced 5 pin 2 CH and Toslink Audio Port /SPDIF** - This matrix has down-mixing built in. What this means is both the SPDIF and 5 ping ports will ALWAYS be down-mixed to 2 CH.

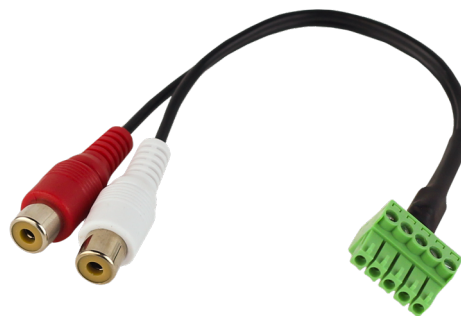

# Audio Output Logic and Cable Prep:

You can extract audio from Toslink or balance 2 CH Audio. Audio outputs are automatically down-mixed to 2 CH.

**2 CH Balanced Audio Port** - Supports 2 CH PCM audio only, which is ideal for 2 Channel systems and zoned audio systems. No Down-mixing on this version, see AC-AXION-4-AVDM.

**Toslink Audio Port** - Just like the balanced 2 CH ports, the Toslink extracted audio ports are down-mixed to 2 CH.

You can use balanced analog outputs in a balanced system, but you can also prep a cable as shown below to convert to a traditional 2 CH unbalanced (L/R) system. You can also purchase pre-made cables (AC-CABLE-5PIN-2 CH) four of these are included in the box when purchased.

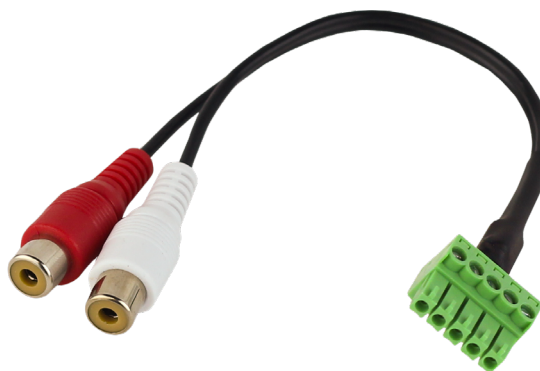

AC-CABLE-5PIN-2 CH

## AUDIO CONNECTION DIAGRAM

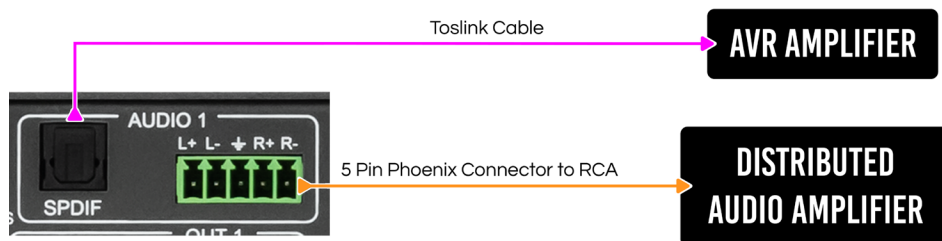

AC-CABLE-5PIN-2CH



# Troubleshooting

- Verify Power - Check that the power supply is properly connected and on an active circuit.
- Verify Connections - Check that all cables are properly connected.
- TX/RX Indicator Troubleshooting Lights - Page(s) [40-41](#)
- IR Issues - Verify correct connections - Page(s) [37-38](#)

Note: Visibly flashing Emitters may not function properly, if you are experiencing issue try the IR Cables that are included in the box.

- Lights indicate everything is good but still not getting a picture, this may be a bandwidth limitation. See Bandwidth Chart below to verify the signal is not exceeding the bandwidth of the Extender kit (limited to 10.2Gbps).

## Bandwidth Chart

TYPE	RESOLUTION	FRAME RATE (FPS)	COLOUR COMPRESSION	DEEP COLOUR BIT DEPTH	HDR	WIDE COLOR GAMUT (BT2020)	HDMI VERSION	DATA RATE	AUHD SERIES
HD	1920x1080	24	4:2:2	8 BIT	NO	NO	1.4	0.75 GBPS	YES
HD	1920x1080	60	4:2:2	8 BIT	NO	NO	1.4	4.45 GBPS	YES
HD	1920x1080	60	4:4:4	16 BIT	NO	NO	1.4	5.91 GBPS	YES
UHD	3840x2160	24	4:2:0	8 BIT	NO	NO	1.4	8.91 GBPS	YES
UHD	3840x2160	24	4:4:4	8 BIT	NO	NO	1.4	8.91 GBPS	YES
4K	4096x2160	24	4:4:4	8 BIT	NO	NO	1.4	8.91 GBPS	YES
UHD OR 4K	3840x2160	60	4:2:0	8 BIT	NO	NO	1.4/2.0	8.91 GBPS	YES
UHD OR 4K	3840x2160	24	4:2:0	10 BIT	YES	YES	2.0(A/B)	8.91 GBPS	YES
UHD OR 4K	3840x2160	24	4:2:2	12 BIT	YES	YES	2.0(A/B)	11.14 GBPS	YES
UHD OR 4K	3840x2160	24	4:4:4	10 BIT	YES	YES	2.0(A/B)	11.14 GBPS	YES
UHD OR 4K	3840x2160	24	4:4:4	12 BIT	YES	YES	2.0(A/B)	13.37 GBPS	YES
UHD OR 4K	3840x2160	60	4:2:0	10 BIT	YES	YES	2.0(A/B)	11.14 GBPS	YES
UHD OR 4K	3840x2160	60	4:2:0	12 BIT	YES	YES	2.0(A/B)	13.37 GBPS	YES
UHD OR 4K	3840x2160	60	4:2:2	12 BIT	YES	YES	2.0(A/B)	17.82 GBPS	YES
UHD OR 4K	3840x2160	60	4:4:4	8 BIT	YES	YES	2.0(A/B)	17.82 GBPS	YES

# Maintenance

To ensure reliable operation of this product as well as protecting the safety of any person using or handling this device while powered, please observe the following instructions.

- Use the power supplies provided. If an alternate supply is required, check voltage, polarity and that it has sufficient power to supply the device it is connected to.
- Do not operate these products outside the specified temperature and humidity range given in the above specifications.
- Ensure there is adequate ventilation to allow this product to operate efficiently.
- Repair of the equipment should only be carried out by qualified professionals as these products contain sensitive components that may be damaged by any mistreatment.
- Only use this product in a dry environment. Do not allow any liquids or harmful chemicals to come into contact with these products.
- Clean this unit with a soft, dry cloth. Never use alcohol, paint thinner or benzene to clean this unit.

## Damage Requiring Service

The unit should be serviced by qualified service personnel if:

- The DC power supply cord or AC adapter has been damaged
- Objects or liquids have gotten into the unit
- The unit has been exposed to rain
- The unit does not operate normally or exhibits a marked change in performance
- The unit has been dropped or the housing damaged

Should you experience any problems while using this product, first, refer to the Troubleshooting section of this manual before contacting Technical Support. When calling, the following information should be provided:

- Product name and model number
- Product serial number
- Details of the issue and any conditions under which the issue is occurring
- Clean this unit with a soft, dry cloth. Never use alcohol, paint thinner or benzene to clean this unit.

## Warranty

### THE BASICS.

AVPro Edge warrants its products that are purchased from all Authorized AVPro Edge Resellers or direct purchases. Products are guaranteed to be free from manufacturing defects and of sound physical and electronic condition.

AVPro Edge has developed a warranty that anyone can get behind. We really wanted to take all the "red tape" out of a warranty and just make it simple. Our 10 YEAR NO BS warranty hinges on 3 elements.

1. If you are having trouble, call us. We will attempt to troubleshoot your issue over the phone.
2. If it's broke - We'll replace it in advance on our dime. (We'll cover return shipping too.) Repair is an option too, but it's YOUR call.
3. We know you know what you are doing. We will not make you go through unnecessary steps to troubleshoot an extender...

### COVERAGE DETAILS.

AVPro Edge will replace or repair (at customer choice) the defective product. If the product is out of stock or on back order it can either be replaced with a comparable product of equal value/feature set (if available) or repair.

Your warranty begins at receipt of product (as confirmed by shipping firm tracking). If tracking information is unavailable for any reason, the warranty will commence 30 ARO (After Receipt of Order). The coverage continues for 10 YEARS.

## **RED TAPE.**

AVPro Edge is not responsible for untraceable purchases or those that were made outside of an authorized channel.

If we conclude that a product or serial number has been tampered with as identified by warranty seal or physical examination the warranty will be void. Additionally, excessive physical damage (beyond normal wear & tear) the warranty may be voided or pro-rated based on the extent of the damage as examined by an AVPro Edge representative.

Damage caused by "acts of God" are not covered. They can include natural disasters, power surges, storms, earthquakes, tornadoes, sink holes, typhoons, tidal waves, hurricanes, or any other uncontrollable event related to nature.

Damage caused by incorrect installation will not be covered. Incorrect power supply, inadequate cooling, improper cabling, inadequate protection, static discharge are examples of this.

Products installed or sold by a third party to AVPro Edge will be serviced by the Authorized AVPro Edge Reseller.

Accessories (IR Cables, RS-232, Power Supplies, etc...) are not included in the warranty. We will make acceptable effort to source and supply replacements for defective accessories at a discounted rate as needed.

## **OBTAINING AN RMA.**

Dealers, Re-sellers, and Installers can request an RMA AVPro Edge Tech Support Rep or their Sales Engineer. Or you may email [support@avproedge.com](mailto:support@avproedge.com) or fill out the general contact form at [www.avproedge.com](http://www.avproedge.com)

End users may not request an RMA directly from AVPro Edge and will be referred back to the Dealer, Re-seller or Installer.

## **SHIPPING.**

For USA (not including Alaska and Hawaii). Shipping is covered on advanced replacements for FedEx Ground (some expressed exceptions may apply). Defective product return shipping is covered by AVPro Edge using an emailed return label. Item must be returned within 30 days of receipt of replacement product, after 30 days, the customer will be billed. Other return shipping methods will not be covered.

For International (and Alaska and Hawaii) return shipping costs will be the responsibility of the returnee. Once the unit is scanned for return shipping AVPro Edge will ship new unit for replacement.

## **LEGAL STUFF.**

Limitation on Liability

The maximum liability of AVPro Global Holdings LLC under this limited warranty shall not exceed the actual purchase price paid for the product. AVPro Global Holdings LLC is not responsible for direct, special, incidental or consequential damages resulting from any breach of warranty or condition, or under any other legal theory to the maximum extent permitted by law.

Taxes, Duties, VAT, and freight forwarding service charges are not covered or paid for by this warranty.

Obsolescence or incompatibility with newly invented technologies (after manufacture of product) is not covered by this warranty.

Obsolescence is defined as:

“Peripherals are rendered obsolete when current technology does not support product repair or re-manufacture. Obsolete products cannot be re-manufactured because advanced technologies supersede original product manufacturer capabilities. Because of performance, price and functionality issues, product redevelopment is not an option.”

Discontinued or out of production items will be credited at fair market value towards a current product of equal or comparable capabilities and cost. Fair market value is determined by AVPro Edge.

### **Exclusive Remedy**

To the maximum extent permitted by law, this limited warranty and the remedies set forth above are exclusive and in lieu of all other warranties, remedies and conditions, whether oral or written, express or implied. To the maximum extent permitted by law, AVPro Global Holdings LLC specifically disclaims any and all implied warranties, including, without limitation, warranties of merchantability and fitness for a particular purpose. If AVPro Global Holdings LLC cannot lawfully disclaim or exclude implied warranties under applicable law, then all implied warranties covering this product, including warranties of merchantability and fitness for a particular purpose, shall apply to this product as provided under applicable law.

This warranty supersedes all other warranties, remedies and conditions, whether oral or written, express or implied.





Thank you for choosing AVProEdge!

Please contact us with any questions, we are happily at your service!

**AVPro** edge



AVProEdge  
2222 E 52nd St N ~ Sioux Falls, SD 57104

1-877-886-5112 ~ 605-274-6055  
[support@avproedge.com](mailto:support@avproedge.com)