

DVDO



DVDO-H265-4KENC-1 Encoder DVDO-H265-4KDEC-1 Decoder with Video Wall

4K60 H.265/H.264 AV over IP System

User Manual

Version v1.0

Disclaimer

The product name and brand name may be registered trademark of related manufactures. ™ and ® may be omitted on the user manual. The pictures in this user manual are just for reference. We reserve the right to make changes without further notice to a product or system described herein to improve reliability, function or design.

• Important Safety Instructions

- 1) Do not expose this device to rain or place it near water. Any liquid that goes into the device may cause a failure, fire, or electric shock.
- 2) Never insert anything metallic into the open parts of this device. This may cause a danger of electric shock.
- 3) Do not place this device near or over a radiator or heat register, or where it is exposed to direct sunlight.
- 4) The device should be repaired only by a qualified technician.
- 5) If a third-party power supply is used, please ensure that the power supply specifications meet the product requirements.

• Introduction

The DVDO-H265-4KENC-1 encoder and DVDO-H265-4KDEC-1 decoder work seamlessly together to deliver high performance AV over IP distribution.

Connected through an IGMP enabled network switch, they provide flexible switching, extension and distribution of 4K@60Hz audio and video signals across your network, supporting up to 256 encoders and 256 decoders.

Powered by advanced H.265 technology, the system delivers high-definition and low-latency transmission up to 120m (394 ft), while supporting one-to-one, one-to-many and many-to-many setups as well as advanced video wall configurations.

The system can be controlled via a free app (iOS or Android) or front panel buttons. Designed for professional integration, it also features PoE as well as bi-directional IR, RS-232 & I/O control pass-through.

• Features

1. Built on advanced technology to deliver high-definition and low-latency transmission.
2. Supports up to 3840 x 2160@60Hz resolution, backwards compatible.
3. Compatible with Cat5e/6 and above networking cables, transmission distance up to 120 meters with Cat6 cables.
4. Supports one-to-one or many-to-many connections through the gigabit switch.
5. Supports RS-232 passthrough and control.
6. The encoder includes an HDMI loop out.
7. Supports bi-directional IR pass-through (20 ~ 60KHz); Supports IR learning remote and control device with app.
8. Supports I/O interface control.
9. Supports PoE (Power over Ethernet).
10. Creating multi-screen splicing with up to 5x5 (also include 1x1/1x2/1x3/1x4/1x5/2x1/2x2/2x3/2x4/2x5/3x1/3x2/3x3/3x4/3x5/4x1/4x2/4x3/4x4/4x5/5x1/5x2/5x3/5x4/5x5) video wall through switch and controlled by app.
11. Supports 256 signal source inputs and 256 signal outputs, providing flexible many-to-many matrix configuration (Require app control operation while connecting more than 100 TX-to-RXs).
12. Firmware upgrade via Micro USB port.
13. Lightning protection, surge protection, ESD protection.
14. Stable 24/7 operation.

• Package Contents



OR





User manual x1

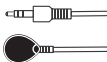

IR receiver extension cable x1

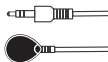

IR blaster extension cable x1



Mounting ear x2



Screw x5



Grounding Screw x1



Terminal block (3P) x1



Terminal block (4P) x1



DC5V/2A Power adapter x 1

• Installation Requirements

Item	Description	Requirement
Signal source device	PC, DVD, NVR, etc. with HDMI port	HDMI cable ≤ 5m
Cable	Cat5e/6 or above, following standard IEEE-568B	Cat6/6A/7 ≤ 120m
Display device	TV, projector, LED screen, etc. with HDMI port	HDMI cable ≤ 5m
Network switch	one-to-many or switch cascade	IGMP PoE Gigabit switch
Router	Use the app to control the product while in the same network	Gigabit bandwidth or higher

• Mounting Instructions

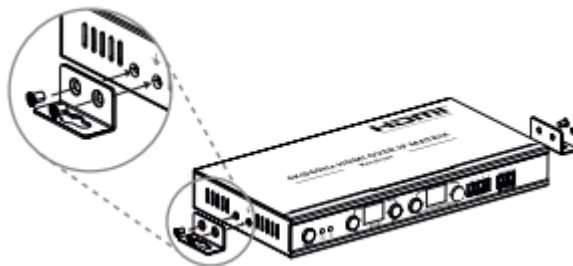

Note: Choose the wall mounting position and attach the mounting ears to the unit according to the diagram.

• Device Description

1. Encoder (Tx)

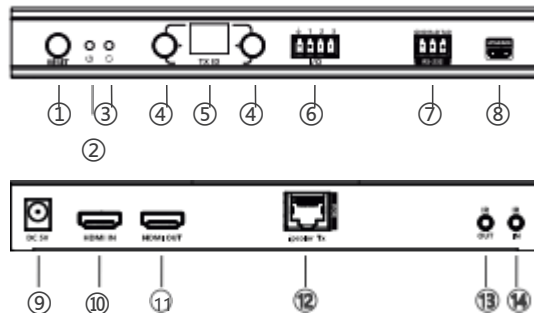

①	Reset	1) Press to restart the device 2) Press and hold for 5 seconds to restore factory settings
②	Power indicator	Indicator lights up when power is applied
③	Status indicator	1) Light off: The encoder and the decoder have not established a connection 2) Flash: The encoder and the decoder are connected but no video data transmission 3) Steady on: The video data is transmitting
④	Encoder ID setting button	Set up the ID of the encoder When using more than one TX, you need to change the TX ID to a different number, such as 01/02/03
⑤	Encoder ID indicator	Indicate the ID of the encoder
⑥	I/O interface	Use the terminal block to connect the external device, and control the output signal via the control APP
⑦	RS-232 (GND/RXD/TXD)	1) RS-232 passthrough commands for TX/RX 2) RS-232 control commands for APP
⑧	Micro USB port	For firmware upgrading
⑨	Power	Connect with DC5V/2A power adapter
⑩	HDMI input	Connect with HDMI source device
⑪	HDMI output	Connect with HDMI display device
⑫	ipcolor Tx	Connect with CAT5e/6 or higher-level networking cables (PoE input)
⑬	IR output	Connect with IR blaster extension cable
⑭	IR input	Connect with IR receiver extension cable

2. Decoder (Rx)

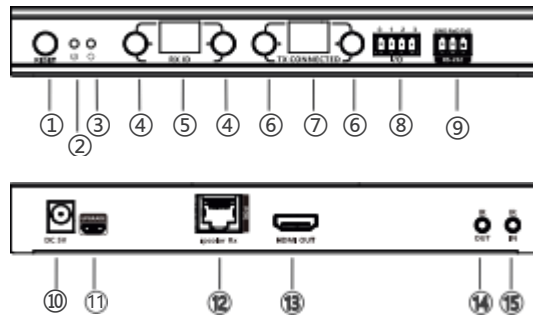

①	Reset	1) Press to restart the device 2) Press and hold for 5 seconds to restore factory settings
②	Power indicator	Indicator lights up when power is applied
③	Status indicator	1) Light off: The encoder and the decoder have not established a connection 2) Flash: The encoder and the decoder are connected but no video data transmission 3) Steady on: The video data is transmitting
④	Decoder ID setting button	Set up the ID of the decoder
⑤	Decoder ID indicator	Indicate the decoder' s ID
⑥	Encoder connected ID setting button	Set the ID of the encoder connected

⑦	Encoder connected ID indicator	Indicate the ID of the encoder connected
⑧	I/O interface	Use the terminal block to connect the external device, and control the output signal via the control app
⑨	RS-232 (GND/RXD/TXD)	1) RS-232 passthrough commands for TX/RX 2) RS-232 control commands for app
⑩	Power	Connect with DC5V/2A power adapter
⑪	Micro USB port	Firmware upgrade
⑫	LAN Rx	Connect with CAT5e/6 or higher-level networking cables (PoE input)
⑬	HDMI output	Connect with HDMI display device
⑭	IR output	Connect with IR blaster extension cable
⑮	IR input	Connect with IR receiver extension cable

• Installation Instructions

1. How to Make a Network Cable



Follow the standard of IEEE-568B:

- 1 -white and orange 2-orange 3-white and green 4-blue
5-white and blue 6-green 7-white and brown 8-brown

2. Connection Diagrams

2.1 One-to-one connection

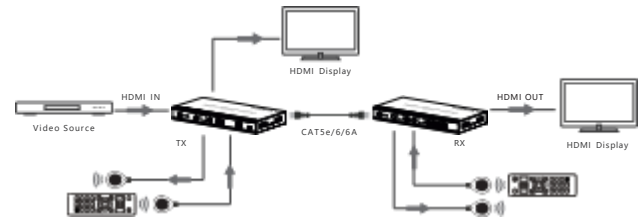

2.2 Many-to-many connection (through gigabit switch):

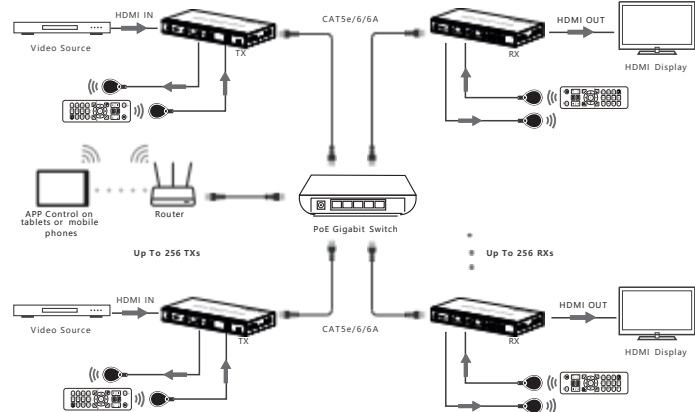

2.3 Many-to-many switch cascade connection (through gigabit switch):

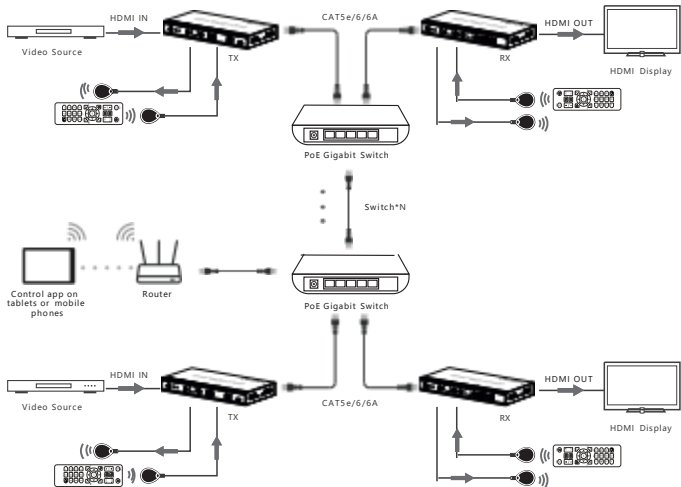

2.4 Creating multi-screen splicing with up to 5x5 video wall through switch and controlled by app.

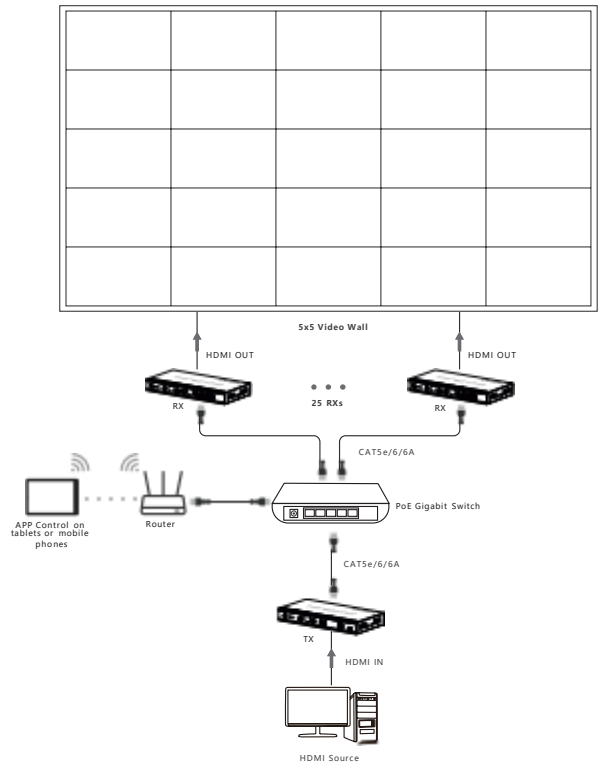

Note: It is suggested to use gigabit (1000 Mbps) IGMP PoE switches in LAN transmission. DO NOT mix 100Mbps and gigabit switches when using switches cascading. The capacity of connecting encoders and decoders units when using switch cascading depends on the switch bandwidth.

3. Connection Instructions

- 1) Connect the source device to the HDMI IN port of the encoder with an HDMI cable, and connect the HDMI OUT port of the decoder to the display device with another HDMI cable.
- 2) If the connection is one-to-one, connect the RJ45 port of the encoder and decoder with an Ethernet cable. If the connection is one-to-many, utilize the IGMP PoE gigabit switch as a bridge to connect the encoders and decoders with Ethernet cables.
- 3) HDMI loop out: connect the display device to the HDMI OUT port of the encoder.
- 4) IR pass-back: insert the IR blaster extension cable into IR OUT and the IR receiver extension cable into IR IN.
- 5) RS-232 control: insert the terminal block in the RS-232 port of the encoder or decoder, and then connect it to the computer or control device.
- 6) I/O control: insert a wiring terminal into the I/O interface of the encoder and decoder, then connect it to an external device.
- 7) Plug the power supply into the devices to get started.

4. IR Control

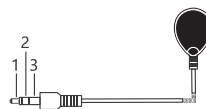

IR blaster

1. Power
2. IR Signal
3. Null

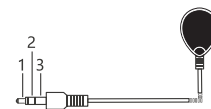

IR receiver

1. Power
2. IR Signal
3. Grounding

- 1) IR blaster extension cable should plug in the IR OUT port of the encoder or decoder, IR receiver extension cable should plug in the IR IN port of the encoder or decoder.
- 2) The emitter of the IR blaster extension cable should be as close as possible to the IR receiving window of the source device.
- 3) Point the remote control at the receiving head of the IR receiver extension cable to operate.

5. RS-232 Control

5.1 Baud rate

Different encoding mechanisms cannot be mixed, the baud rate of the RS-232 port of this encoder and decoder is 2400, 4800, 9600, 19200, 38400, 57600, 115200.

5.2 Line order

Make sure the RS-232 serial line is firmly connected and that the serial data line is connected correctly as follows:

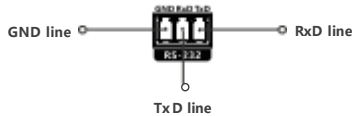

If the RS-232 serial does not work by following the above connection, please try to change the order of the TXD line and RXD line.

5.3 Check baud rate



If you need to check the baud rate, set the baud rate value of the serial port test tool to the default value of 115200, connect the serial port test tool to the product, and then power on the product. The baud rate printed at this time is the current baud rate. For example:

" Baudrate:9600 ", that is, the baud rate value is 9600.

5.4 Set baud rate

For example: the baud rate of the product is 9600, and the baud rate of the serial port test tool is 115200. At this time, the baud rate of the serial port test tool must be set to 9600, which is consistent with the product, and then input the command you want to set "Bset:19200", if "Succeed" is displayed after sending data, the baud rate 19200 is set successfully.

6. ID Control

Adjust the ID indicator value of the LED display by pressing the buttons on the left and right of "TX ID"  on the encoders, and "RX ID"  and "TX CONNECTED"  on the decoders.

The left button controls the left digit, and the right button controls the right digit (the original display value of "00", after pressing both the left and right button, the display value of the LED display changes to "11").

The connection is established when the display value of "TX ID" on the encoders is the same as that of "TX CONNECTED" on the decoders.

Short press: Set the IGMP group and display the settled value, the product automatically switches to the corresponding IGMP group after 5 seconds pressing.

• Control App



The control app is called iMMS for ipcolor. Download the iOS app from the App Store or the Android app from the Google Play Store.

Note: we recommend using a tablet with a SOC Snapdragon 865 or above, 8GB or more of RAM, and a gigabit network to guarantee optimal experience.

For instructions on using the app interface, please refer to the Control App Interface document available in the Downloads section of the encoder/decoder product page on the DVDO website.

• FAQs

Q: Why is the status indicator off?

A: Please check whether all equipment is powered on and the networking cable is connected properly.

Q: Why is the status indicator has been flashing?

A: Please check whether there is HDMI signal input for the TX. Try to connect the signal source directly to the display device, or try to change the signal source and HDMI cable and test again.

Q: Why is the output image unstable?

A: Check whether the length of the Ethernet cable is within the specified range, the length of HDMI cable is recommended to be ≤ 5 meters. Press the "reset" button on TX and RX panels to restart and reconnect.

• Technical Parameters

Item	Encoder (Tx)	Decoder (Rx)
Video		
Input interface	1 × HDMI	1 × RJ45
Output interface	1 × HDMI 1 × RJ45	1 × HDMI
HDMI length	≤ 5 m	≤ 5 m
Maximum transfer rate	18Gbps	
Compatibility	HDMI 2.0	
	HDCP 1.4/HDCP 2.2	
Resolutions	4096x2160@24/30Hz, 3840x2160@24/30/50/60Hz, 1080p@50/60Hz,720p@50/60Hz, 1920x1200@60Hz, 2560x1440@60Hz	
Connection types	One-to-one connection Many-to-many connection Switch cascading	
Transmission distance	CAT5E 100m / CAT6 120m	
Transmission latency	4K@60Hz: 130~200ms	
	1080P@60Hz: 70~130ms	
Audio signal		
Input interface	1 × HDMI	1 × RJ45
Output interface	1 × HDMI 1 × RJ45	1 × HDMI
HDMI output	LPCM 2.0	
Command Signal		
Input interface	1x 3.5mm IR input 1x 3.5mm IR output	1x 3.5mm IR input 1x 3.5mm IR output
IR receiving range	≤ 5 m	
IR frequency	20kHz~60kHz	

RS-232 (GND/RXD/TXD)	Default baud rate: 115200 Supported: 2400, 4800, 9600, 19200, 38400, 57600, 115200	
Power		
Power Supply	DC 5V/2A(alternative)	DC 5V/2A(alternative)
Power Consumption	TX ≤ 5.5W	RX ≤ 3.5W
Operating Environment		
Working temperature	- 20°C~60°C	
Storage temperature	- 30°C~70°C	
Humidity	0~90%RH (no condensation)	
Physical Properties		
Housing	Metal	
Weight	523g	514g
Color	Black	
Dimensions	191.0(L)*96.0(W)*25.0(H)mm	
Protection	ESD protection 1a Contact discharge level 2 (±4KV) 1b Air discharge level 3 (±8KV) Implementation of the standard: IEC61000-4-2	
	Lightning protection, Surge protection	

DVDO

Follow us

