

# DVDO



## DVDO-USBC-HDMI-PS-21-XL

4K 2x1 Presentation Switcher with USB-C & HDMI Inputs,  
Audio Input & Output, 2 LAN Ports

## User Manual

Version v1.0

## Thank you for purchasing DVDO-USBC-HDMI-PS-21-XL

For optimum performance and safety, please read these instructions carefully before connecting, operating or adjusting this product. Please keep this manual for future reference.

## Surge protection device recommended

This product contains sensitive electrical components that may be damaged by electrical spikes, surges, electric shock, lightning strikes, etc. Use of surge protection systems is highly recommended in order to protect and extend the life of your equipment.

## Table of Contents

1. Introduction .....	1
2. Features .....	1
3. Package Contents. ....	2
4. Specifications. ....	3
5. Operation Controls and Functions. ....	6
6. IR Cable Pin Assignment.....	8
7. Web GUI User Guide. ....	9
8. API Commands. ....	26
9. Application Example. ....	46

# 1. Introduction

DVDO-USBC-HDMI-PS-21-XL is a 2x1 Huddle Room Switcher with multiple control methods, designed with one HDMI™ and one USB-C inputs, one HDMI™ output, one USB host, one USB-C device, two USB-A devices, dual 1G Ethernet ports. Video resolution is up to 4K@60Hz 4:4:4, delivering high-quality visuals for presentations and displays. Audio embedding and de-embedding on a balanced analog audio interface, ensuring clear and synchronized audio record and playback.

DVDO-USBC-HDMI-PS-21-XL also supports USB KVM, RS-232, GPIO, IR and Ethernet switching functions, as well as auto and manual switching, auto signal detection and wake up the whole system including external devices. It can be controlled via front panel button, RS-232, TCP/IP and Web GUI. It features multiple interfaces for the easy connection between the BYOD devices and the meeting room devices, providing versatility and enhanced connectivity for presentation environments. It is designed to meet the demands of modern huddle room setups, providing a user-friendly and feature-rich solution for enhanced connectivity and control.

## 2. Features

- ☆ HDCP 2.3 and DP 1.4a compliant
- ☆ 2x1 huddle room switcher with USB-C/HDMI™ input and HDMI™ output
- ☆ USB-C input with DP Alt mode up to 4K60Hz 4:4:4, USB 3.2 Gen 1 (5Gbps), 1G ethernet and 100W charging
- ☆ HDMI™ input up to 4K60Hz 4:4:4, as specified in HDMI™ 2.0b
- ☆ Fast switching including auto and manual switching
- ☆ Auto switching with signal detection and 5V detection

(Continued)

- ☆ USB 3.2 Gen 1 (5Gbps) host and local hub
- ☆ USB 3.2 Gen 1 (5Gbps) device with 5V/1.5A power output
- ☆ Support balanced/un-balanced analog audio embedding to USB or HDMI™ audio
- ☆ Support balanced/un-balanced analog audio de-embedding from USB or HDMI™ audio
- ☆ Advanced EDID management
- ☆ User defined welcome screen and no signal display image
- ☆ Dual 1G Ethernet ports with 802.1x and VLAN
- ☆ IR eye for IR learning and control
- ☆ Auto display on/off control
- ☆ External device control via CEC/IR/RS-232/LAN/GPIO
- ☆ Control via front panel buttons, RS-232, TCP/IP and Web GUI

### 3. Package Contents

- ① 1× DVDO-USBC-HDMI-PS-21-XL Huddle Room Switcher
- ② 1× 24V/7.5A Power Supply
- ③ 1× IR Blaster Cable (1.5m)
- ④ 1× 3pin-3.5mm Phoenix Connector (male)
- ⑤ 2× 5pin-3.5mm Phoenix Connector (male)
- ⑥ 1× 6pin-3.5mm Phoenix Connector (male)
- ⑦ 4× Rubber Foot
- ⑧ 2× Mounting Ear
- ⑨ 4× Machine Screw (M3\*5, for rubber feet)
- ⑩ 4× Machine Screw (KM3\*6, for mounting ears)
- ⑪ 1× User Manual

## 4. Specifications

Technical	
HDMI™ Compliance	HDMI™ 2.0b
HDCP Compliance	HDCP 2.3
DP Compliance	DP 1.4a (USB-C input)
USB Compliance	USB 3.2 Gen1 (5Gbps)
Video Bandwidth	18Gbps
Video Network Bandwidth	1G
Video Resolution (Input&Output)	640x480p60Hz, 800x600p60Hz, 1024x768p60Hz, 1280x1024p60Hz, 1360x768p60Hz, 1440x900p60Hz, 1440x1050p60Hz, 1600x1200p60Hz, 720x480i59.94Hz(480i59), 720x480p59.94Hz(480p59), 720x576i50Hz(576i50), 720x576p50Hz(576p50), 1280x720p50Hz(720p50), 1280x720p59.94Hz(720p59), 1280x720p60Hz(720p60), 1920x1080i50Hz(1080i50), 1920x1080i59.94Hz(1080i59), 1920x1080i60Hz(1080i60), 1920x1080p23.98Hz(1080p23), 1920x1080p24Hz(1080p24), 1920x1080p25Hz(1080p25), 1920x1080p29.97Hz(1080p29), 1920x1080p30Hz(1080p30), 1920x1080p50Hz(1080p50), 1920x1080p59.94Hz(1080p59), 1920x1080p60Hz(1080p60), 3840x2160p23.98Hz(2160p23), 3840x2160p24Hz(2160p24), 3840x2160p25Hz(2160p25), 3840x2160p29.97Hz(2160p29), 3840x2160p30Hz(2160p30), 3840x2160p50Hz(2160p50), 3840x2160p59.94Hz(2160p59), 3840x2160p60Hz(2160p60), 4096x2160p23.98Hz, 4096x2160p24Hz, 4096x2160p25Hz, 4096x2160p29.97Hz, 4096x2160p30Hz, 4096x2160p50Hz, 4096x2160p59.94Hz, 4096x2160p60Hz
Color Space	RGB, YCbCr_4:4:4, YCbCr_4:2:2, YCbCr_4:2:0
Color Depth	8/10/12-bit, 8-bit (4K@60Hz, 4:4:4)
HDR	HDR, HDR10, HDR10+, Dolby Vision, HLG
Audio Formats	<b>HDMI™/USB-C IN, HDMI™ OUT:</b> LPCM, Dolby Digital/Plus/EX, Dolby True HD, Dolby Atmos, DTS, DTS-EX, DTS-96/24, DTS High Res, DTS-HD Master Audio, DSD

Technical		
Audio Formats	<b>Analog Audio IN/OUT:</b> LPCM 2CH (sample rate 32~192kHz)	
Audio In	Input Impedance	20K Ohm balanced 10K Ohm unbalanced
	Input Level	Max 8.2dBu (2Vrms) balanced audio
	Frequency Response	20Hz to 20kHz (-/+0.5dB)
	Dynamic Range	>90dB@0dBu, 1kHzA-weighted
	Audio S/N Ratio	>90dB@0dBu, 1kHzA-weighted
	Audio THD+N	< 0.01% at +4dBu, 1KHz
	Audio Output Delay	<1ms
Audio Out	Output Impedance	600 Ohm balanced 300 Ohm unbalanced
	Output Level (Maximum)	Max 8.2dBu (2Vrms) balanced audio Max 2.2dBu (1Vrms) unbalanced audio
	Frequency Response	20Hz to 20kHz (-/+1dB)
	Dynamic Range	>90dB@0dBu, 1kHzA-weighted
	Audio S/N Ratio	>90dB@0dBu, 1kHzA-weighted
	Audio THD+N	< 0.067% at +4dBu, 1KHz
	Audio Output Delay	<1ms
IR Level	5Vp-p	
IR Frequency	20K-60KHz	
Transmission Distance	USB 3.2 Passive Cable: 1.5m/4.9ft HDMI™ Passive Cable: 3m/9.8ft	
ESD Protection	IEC 61000-4-2: ±8kV (Air-gap discharge) & ±4kV (Contact discharge)	

<b>Connection</b>	
Input ports	1× IN2 [HDMI™ Type A, 19-pin female] 1× USB-C IN1 [USB-C, 24-pin female] 1× HOST [USB Type B, 9-pin female] 1× L/R AUDIO IN [5-pin 3.5mm phoenix connector]
Output ports	1× OUT [HDMI™ Type A, 19-pin female] 1× USB DEVICE [USB Type C, 24-pin female] 2× USB DEVICE [USB Type A, 9-pin female] 1× L/R AUDIO OUT [5-pin 3.5mm phoenix connector]
Control ports	1× RS-232 [3-pin 3.5mm phoenix connector] 1× IR OUT [3.5mm stereo mini-jack] 2× LAN [RJ45 connector] 1× GPIO [6-pin 3.5mm phoenix connector] 1× SERVICE [USB-C, FW update port]
<b>Mechanical</b>	
Housing	Metal Enclosure
Color	Black
Dimensions	230mm [W] × 130mm [D] × 23mm [H]
Weight	796g
Power Supply	Input: AC 100-240V 50/60Hz, Output: DC 24V/7.5A (US/EU standard, CE/FCC/UL certified)
Power Consumption	37W (without USB-C charging); 145W (with 100W USB-C charging)
Operating Temperature	32°F - 104°F / 0°C - 40°C
Storage Temperature	-4°F - 140°F / -20°C - 60°C
Operating Humidity	20%~80% relative humidity, non-condensing
Storage Humidity	10%~90% relative humidity, non-condensing

# 5. Operation Controls and Functions

## 5.1 Front Panel

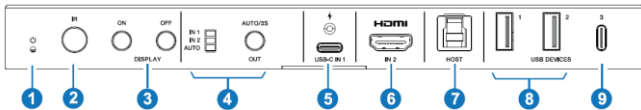

NO.	Name	Function Description
1	Power LED	The LED will light in green when the product is working normally, and red when the product is standby.
2	IR	IR signal receiving window. It can be used for IR learning.
3	DISPLAY ON/OFF	Press to enable or disable the output of display devices. Please refer to "Display Page" in Web GUI for more details.
4	IN1/IN2/AUTO switch button & indicator	<ul style="list-style-type: none"><li>■ Short press the button to switch between IN1 and IN 2. If one channel is selected, the corresponding LED will light up.</li><li>■ Long press the button for 3 seconds to enable or disable the auto switching mode. If the auto switching mode is enabled, the AUTO LED will light up.</li></ul>
5	USB-C IN1	USB-C input port, supporting USB 3.2 Gen 1, DP Alt mode, 1G Ethernet and up to 100W charging. <b>Note 1:</b> The 1G Ethernet function of this port can be enabled or disabled on System page in Web GUI. If the PC connected to this port needs to be online, the Ethernet should be networked. <b>Note 2:</b> When USB-C IN port is connected to a PC, the USB-C port on PC must support DP Alt mode to transmit video signal.
6	HDMI IN2	HDMI signal input port, connected to a source device.
7	HOST	USB-B upstream port, connected to PC or other devices.

NO.	Name	Function Description
8	USB DEVICES 1/2	USB-A downstream port, with output power 5V/1.5A. Connects to USB device.
9	USB DEVICES 3	USB-C downstream port, with output power 5V/1.5A. Connects to USB device.

## 5.2 Rear Panel

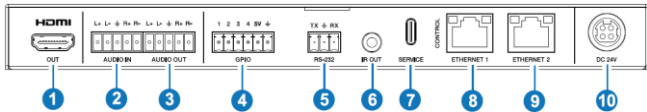

NO.	Name	Function Description
1	HDMI OUT	HDMI signal output port, connected to a display device.
2	L/R AUDIO IN	Analog audio input port, connected to an audio input device such as a microphone. Supports balanced audio input and unbalanced audio input (with a maximum support of 2Vrms). Balanced connection method: L+, L-, GND, R+, R Unbalanced connection method: L+, GND, R+
3	L/R AUDIO OUT	Analog audio output port, connected to an audio output device such as a speaker. Supports balanced audio output (with a maximum support of 2Vrms) and unbalanced audio output (with a maximum support of 1Vrms). Balanced connection method: L+, L-, GND, R+, R Unbalanced connection method: L+, GND, R+
4	GPIO	Used for user-defined function extension.
5	RS-232	RS-232 control port, connected to a PC or control system for API command control on this product or other devices with RS-232 ports.
6	IR OUT	IR signal output port, connected to the IR blaster cable.

NO.	Name	Function Description
7	SERVICE	USB 2.0 type C port, supporting API command control and firmware upgrade.
8	ETHERNET 1	1G Ethernet port, connected to a PC to visit Web GUI of this product to set the parameters.
9	ETHERNET 2	1G Ethernet port, connected to the router to surf the internet via a computer with USB-C port.
10	DC 24V	DC 24V/7.5A power input port.

**Note:**

ETHERNET ports support two modes, you can set it via API command and Web GUI page.

**Separated Mode** (Default): ETHERNET 1 is used for TCP/IP/Web GUI; ETHERNET 2 is used for 1G Ethernet only.

**Switch Mode:** ETHERNET 1 and ETHERNET 2 are both used for TCP/IP/ Web GUI and 1G Ethernet access.

## 6. IR Cable Pin Assignment

IR blaster pin's definition is as below:



## 7. Web GUI User Guide

This product can be controlled by Web GUI. The operation method is shown as below:

**Step 1:** Get the current IP Address.

The default IP address is 192.168.0.100. You can get the current IP address via API command. Send the command “get ip addr” through an ASCII Command tool, and then you’ll get the current IP address (The IP address is variable, depending on what the specific device returns).

For the details of API control, please refer to “8. API Commands”.

**Step 2:** Connect the ETHERNET port of the product to a PC, and set the IP address of the PC to be in the same network segment with the product. For example, if its IP address is 192.168.62.106, the IP address of PC must be set to 192.168.62.xxx; if its IP address is 192.168.0.100, the IP address of PC must be set to 192.168.0.xxx.

**Step 3:** Enter the IP address of the product into your browser on the PC. After entering the Web GUI page, there will be a Login page, as shown below:

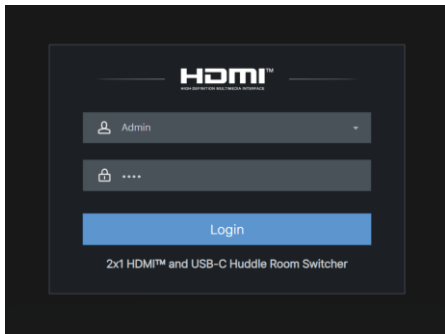

The default usernames and passwords are as below:

Username	Password
Admin	1234
User	1234

Select the username "Admin", enter the default password "1234", and then click "Login". The web page provides the following tabs for navigating the interface:

## ■ Information Page

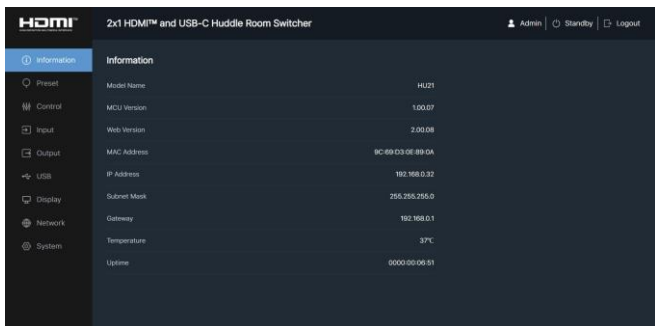

The screenshot shows the web interface for a "2x1 HDMI™ and USB-C Huddle Room Switcher". The top navigation bar includes the HDMI logo, the device name, and user controls for "Admin", "Standby", and "Logout". A left sidebar contains navigation tabs: "Information" (selected), "Preset", "Control", "Input", "Output", "USB", "Display", "Network", and "System". The main content area displays the "Information" page with the following details:

Model Name	HU21
MCU Version	1.00.07
Web Version	2.00.08
MAC Address	9C:89:D3:0E:89:0A
IP Address	192.168.0.32
Subnet Mask	255.255.255.0
Gateway	192.168.0.1
Temperature	37°C
Uptime	0000:00:00:51

The Information page provides basic information such as the Model, the installed firmware version and the network settings of the device.

The buttons at the top right of the web interface are always available:

- Clicking the Logout button will log out and return to the login page.
- Clicking the Standby button will set the matrix to standby mode or power on the matrix.

## ■ Preset Page

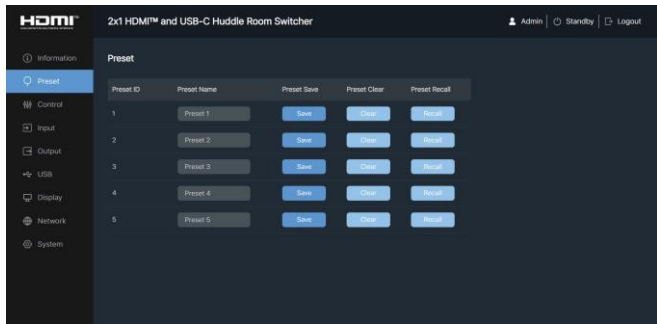

You can set up to 5 preset scenes on the Preset page.

- ① **Preset Name:** You can name the preset scene, up to 16 characters.
- ② **Preset Save:** Click the Save button to save the scene.
- ③ **Preset Clear:** Click the Clear button to clear the saved scene.
- ④ **Preset Recall:** Click the Recall button to recall the saved scene.

## ■ Control Page

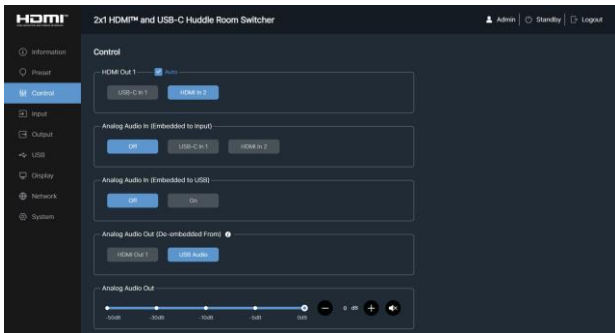

You can do the following operations on the Control page:

① **HDMI Out:** Click "USB-C In 1" or "HDMI In 2" to select the input channel.

If the "Auto" checkbox is ticked, the auto switching mode is enabled.

② **Analog Audio In (Embedded to Input):**

**Off:** Click to turn off the audio embedding function.

**USB-C In 1/HDMI In 2:** Click to embed the audio to the input channel, and it will be output on the TV connected to the HDMI output port.

③ **Analog Audio In (Embedded to USB):**

**Off:** Click to turn off the audio embedding function.

**On:** Click to turn on the audio embedding function.

Now the microphone input can be selected on the PC which is connected to the Host port when the audio embedding function is enabled.

④ **Analog Audio Out (De-embedded From):**

**HDMI Out:** Click to select "HDMI Out" as the source for de-embedding audio.

**USB Audio:** Click to select "USB Audio" as the source for de-embedding audio.

**Note:** When the audio embedding function (Analog Audio In) is enabled, the audio de-embedding function (Analog Audio Out) will not work. That is to say, the audio of "Analog Audio In" can't be routed to "Analog Audio Out" to output.

⑤ **Analog Audio Out:**

Click to increase, decrease or mute the volume.

## ■ Input Page

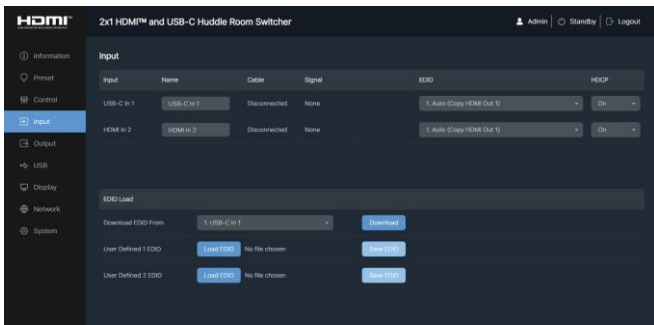

You can do the following operations on the Input page:

- ① **Input:** The input channel of this product.
- ② **Name:** You can modify the name if needed, up to 16 characters.
- ③ **Cable:** It shows the connection status of the input ports.
- ④ **Signal:** It shows the basic info of the input signal.
- ⑤ **EDID:** Click the drop-down list to set EDID for each input port.

The EDID list is shown below:

No.	EDID Mode	No.	EDID Mode
1	Auto (Copy HDMI Out 1)	11	720P60_444, Audio 2CH PCM
2	4K2K60_444, Audio 2CH PCM	12	1920x1200, Audio 2CH PCM
3	4K2K60_444, Audio 5.1CH DTS/ DOLBY	13	1680x1050, Audio 2CH PCM
4	4K2K60_444, Audio 7.1CH DTS/ DOLBY/HD	14	1600x1200, Audio 2CH PCM
5	4K2K30_444, Audio 2CH PCM	15	1440x900, Audio 2CH PCM
6	4K2K30_444, Audio 5.1CH DTS/ DOLBY	16	1360x768, Audio 2CH PCM
7	4K2K30_444, Audio 7.1CH DTS/ DOLBY/HD	17	1280x1024, Audio 2CH PCM
8	1080P60_444, Audio 2CH PCM	18	1024x768, Audio 2CH PCM
9	1080P60_444, Audio 5.1CH DTS/ DOLBY	19	User Defined 1
10	1080P60_444, Audio 7.1CH DTS/ DOLBY/HD	20	User Defined 2

⑥ **HDCP:** Click the drop-down list to select ON or OFF as required.

⑦ **Download EDID from:** Click the drop-down list to select USB-C In 1 / HDMI In 2 / HDMI Out for EDID download. Then click the Download button and generate a .bin file.

⑧ **User-Defined EDID:** Click the Load EDID button to upload the defined EDID. Please note that only two user-defined EDID and .bin files are supported. Click the Save EDID button to save the user-defined EDID. Then it will be displayed in the EDID drop-down list, corresponding to the User Defined 1/User Defined 2.

## ■ Output Page

The screenshot shows the 'Output' page of the HDMI control interface. At the top, it says '2x1 HDMI™ and USB-C Huddle Room Switcher'. The left sidebar has 'Output' selected. The main content area has a table with columns: Output, Name, Cable, Signal, HDCP, Video Mode, and Output Signal. The table has one row: HDMI Out 1, HDMI Out 1, Disconnected, None, 1. Auto, 1. Auto, 1. On. Below the table is the 'Internal Pattern' section with Resolution set to 1. 6000Hz and Pattern set to 1. Back. Below that is the 'Welcome Screen' section with 'Welcome Screen' and 'No Signal Screen' both turned on. There are also options for 'Display Image', 'Load New Image', and 'Clear Current Image'.

You can do the following operations on the Output page:

① **Output:** It shows the information of the output channel, such as name, connection status, HDCP, video mode.

The screenshot shows a close-up of the HDCP dropdown menu. The menu is open, showing four options: 1. Auto, 2. Force HDCP 1.4, 3. Force HDCP 2.2, and 4. Signal Management.

There are four options of HDCP:

**Auto:** HDCP version follows the corresponding display device.

**Force HDCP 1.4:** HDCP 1.4 compliant.

**Force HDCP 2.2:** HDCP 2.2 compliant.

**Signal Management:** Reserved mode.

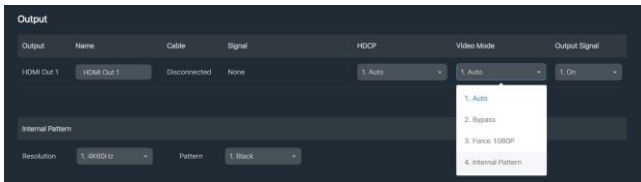

There are four options of Video Mode:

**Auto:** It means the output resolution is according to the EDID of the corresponding display device.

**Bypass:** It means the output resolution follows the input source.

**Force 1080P:** Downscales any 4K signal to 1080p to output.

**Internal Pattern:** User-defined mode.

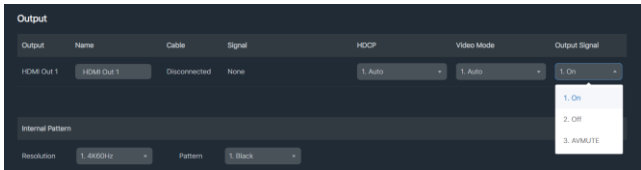

There are three options of Output Signal:

**On:** Turn on the output channel.

**Off:** Turn off the output channel.

**AVMUTE:** Mute the output channel.

② **Internal Pattern:**

**Resolution:** 4K60Hz / 4K50Hz / 4K25Hz / 4K24Hz / 1080P60Hz / 480P60Hz / 576P50Hz

**Pattern:** 1. Black / 2. Checkboard / 3. Strip / 4. Red / 5. Green / 6. Blue / 7. White / 8. Ramp / 9. Red ramp / 10. Green ramp / 11. Blue ramp / 12. PRBS

③ **Welcome Screen:**

**Welcome Screen:** Click to turn on or turn off the welcome screen.

**No Signal Screen:** If there is no signal in 60 seconds, it will display welcome screen automatically. You can click to turn on or turn off the no

signal screen.

**Display Image:** Click to display the starting image for 30 seconds, and then disappear automatically.

**Load New Image:** Click to load the image you want and save it.

**Clear Current Image:** Click to clear the current image.

## ■ USB Page

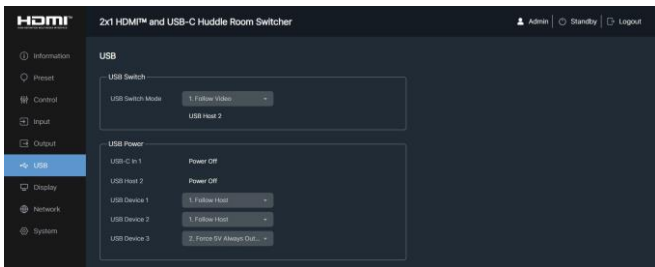

You can do the following operations on the USB page:

① **USB Switch Mode:** Select the USB switch mode.:

- **Follow Video:** Set the USB transmission to follow the video.
- **Manual Switch:** Switch the USB manually as required. Click the dropdown list to select USB-C 1/USB Host 2 as the upstream port.
- **Auto Switch:** Switch the USB automatically. The system will detect and switch to the latest connected port as the upstream port automatically.

② **USB Power:**

**USB-C In 1/USB Host 2:** "Power On" means the power of the upstream device is detected. "Power Off" means the power of the upstream device is not detected.

**USB Device 1/2/3:** Click the drop-down list to set 5V detection for each USB device.

- **Follow Host:** 5V detection of the USB device follows the connection status of the selected host.
- **Force 5V Always Output:** 5V detection of the USB device is forced to be enabled.
- **Disable 5V Output:** 5V detection of the USB device is forced to be disabled.

## ■ Display Page

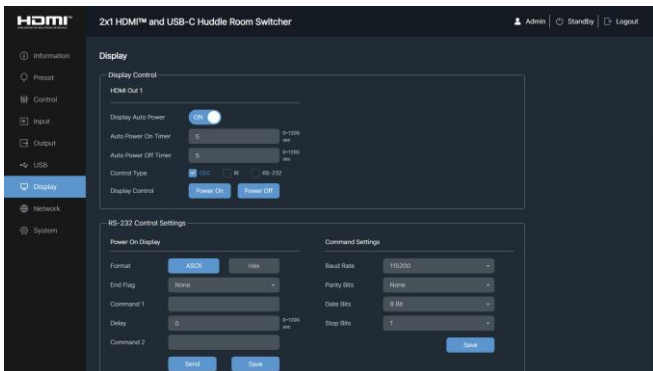

You can do the following operations on the Display page:

### ① Display Control (HDMI Out):

**Display Auto Power:** The display device will be powered on or powered off following the product. You can enable or disable this function.

**Auto Power On Timer (0~1200 seconds):** Set the time interval to send the starting command to the display device when this product is powered on.

**Auto Power Off Timer (0~1200 seconds):** Set the time interval to send the shutdown command to the display device when this product is standby.

**Control Type:** Set the control type of the display device, such as IR, CEC or RS-232.

**Display Control:** Click to turn on or turn off the connected display device.

The screenshot shows a dark-themed interface titled "RS-232 Control Settings". It is divided into four main sections:

- Power On Display:** Includes a "Format" selector (ASCII selected, Hex available), an "End Flag" dropdown (None selected), "Command 1" and "Command 2" text input fields, a "Delay" input (0) with a "0-1200 sec" range indicator, and "Send" and "Save" buttons.
- Command Settings:** Includes "Baud Rate" (115200), "Parity Bits" (None), "Data Bits" (8 Bit), and "Stop Bits" (1) dropdown menus, and a "Save" button.
- Power Off Display:** Includes a "Format" selector (ASCII selected, Hex available), an "End Flag" dropdown (None selected), "Command 1" and "Command 2" text input fields, a "Delay" input (0) with a "0-1200 sec" range indicator, and "Send" and "Save" buttons.
- RS-232 General Command:** Includes a "Format" selector (ASCII selected, Hex available), an "End Flag" dropdown (Select selected), a "Command" text input field, and a "Send" button.

## ② RS-232 Control Settings:

### Power On/Off Display:

Format: ASCII and Hex

End Flag: None, \r, \n, \r\n

Command1: Enter the command1 to control the display device.

Delay: The time interval between sending the command1 and Command2.

Command2: Enter the command2 to control the display device.

Send: Click to send the commands.

Save: Click to save the commands.

### Command Settings:

Click the drop-down list to set Baud Rate, Parity Bits, Data Bits and Stop Bits, and then click "Save".

**RS-232 General Command:** Used to control the third-party device via sending serial command.

Format: ASCII and Hex

End Flag: None, \r, \n, \r\n

Command: Enter the command to control the display device.

Send: Click to send the commands.

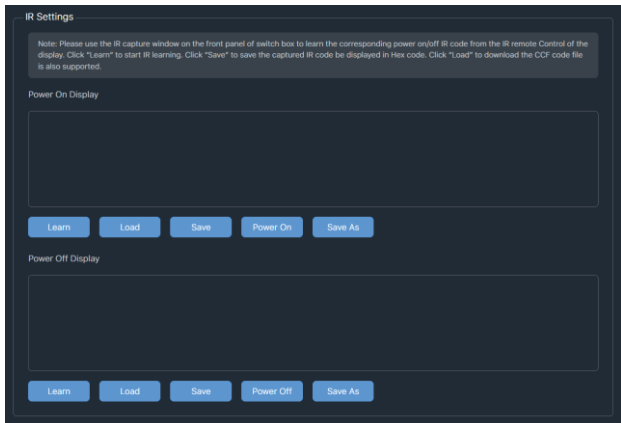

### ③ IR Settings:

#### Power On/Off Display

**Learn:** Click "Learn", and then let the IR remote aim at IR window on the front panel of this switcher to operate. When learning is finished, the Hex code will display in the text box on the IR Setting page.

**Load:** Click to load the CCF code of .bin file.

**Save:** Click to save the learned IR code.

**Power On/Off:** Click to send the IR code in the text box.

**Save As:** Click to save the learned IR code as a .bin file.

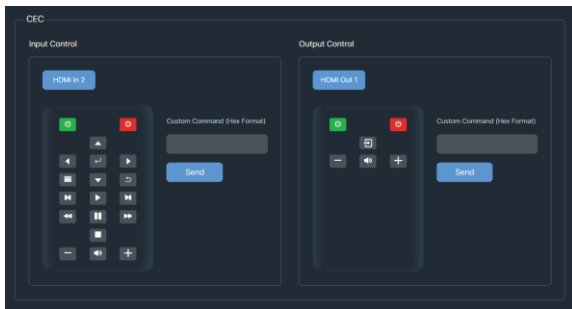

#### ④ CEC:

**Input Control:** Click the buttons to control the source device connected to the HDMI In2 port.

You can also enter a command with Hex format to control.

**Output Control:** Click the buttons to control the display device connected to the HDMI Out port.

You can also enter a command with Hex format to control.

### ■ Network Page

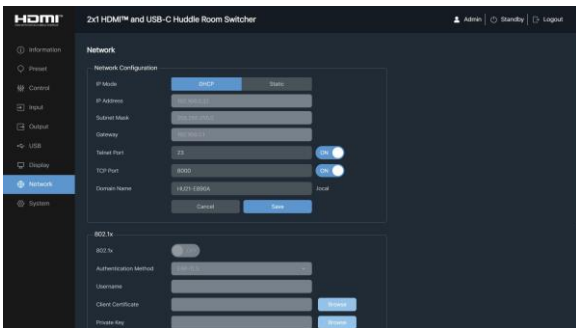

## ① Network Configuration:

If the Mode is “Static”, you can set manually the IP Address/Gateway/ Subnet/Telnet Port/Domain Name as required.

If the Mode is “DHCP”, it will search and be filled with the IP Address assigned by the router automatically. You can't modify it now.

Click “Save” to take effect, and click “Cancel” to cancel the setting.

### Note:

1. The domain name "HU21-E890A.local" can be used to login Web GUI.
2. The Telnet and TCP ports can be turned off if required. Click "Save" to take effect. It is turned on by default.

## ② 802.1x:

**On/Off:** Click to turn on or turn off 802.1x.

**Authentication Method:** EAP-TLS and EAP-MSCHAPv2

**Username:** Enter a username.

**Client Certificate:** Click "Browse" to load the client certificate.

**Private Key:** Click "Browse" to load the private key.

**Private Key Password:** Set the password.

**Serve Certificate:** Click to turn on or turn off.

**CA Certificate:** Click "Browse" to load the CA certificate.  
Then click "Save" to save the settings.

### ③ Network Mode:

#### Mode 1 (Separated Mode):

ETHERNET 1 is used for TCP/IP/Web GUI.

ETHERNET 2 is used for 1G Ethernet only.

#### Mode 2 (Switch Mode):

Both ETHERNET 1 and ETHERNET 2 are used for TCP/IP/Web GUI and 1G Ethernet access.

## ■ System Page

The screenshot displays the 'System' configuration page for an HDMI 2x1 HDMI™ and USB-C Huddle Room Switcher. The page is dark-themed and includes a sidebar with navigation options: Information, Preset, Control, Input, Output, USB, Display, Network, and System (highlighted). The main content area is titled 'System' and contains three sections:

- Auto Switch:** Includes 'Auto Switch Mode' set to 'Input Signal' and 'HDMI Out 1 Fallback' set to '1. Next Input'.
- GPIO:** A table with four rows, each representing a GPIO pin (GPIO 1 to GPIO 4). Each row has a dropdown menu set to '1. Input (Default High Level 5V)', a 'Save' button, and a 'Current Level' indicator set to 'High'.
- System Utilities:** Includes 'Front Panel Key' (ON), 'HDMI Power Saving' (ON), 'USB-C Access Network' (OFF), 'Auto Standby Time' (15 min), and 'RS-232 Baud' (115200).

### ① Auto Switch:

#### Auto Switch Mode:

Two modes are supported: Input Signal and Source 5V.

#### HDMI Out1 Fallback:

There are four options: Next Input, Previous Input, USB-C In1, HDMI In2.

## ② GPIO:

There are four options:

1. Input (default High Level 5V)
2. Input (default Low Level 0V)
3. Output High Level (5V)
4. Output Low Level (0V)

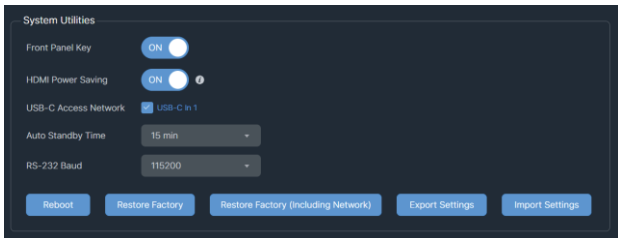

## ③ System Utilities:

**Front Panel Key:** Click to lock or unlock the front panel button.

**HDMI Power Saving:** Click to turn on or turn off the function.

If "HDMI Power Saving" is On, 5V power on the HDMI output port will be turned off when all inputs are not connected.

**Note:** Now the "No Signal Screen" output function is not available if all inputs are not connected.

If "HDMI Power Saving" is Off, 5V power on the HDMI output port will be remained, whether or not any input port is connected or disconnected.

**USB-C Access Network:** If the checkbox is ticked, 1G Ethernet function of the USB-C In1 port will be available.

**Auto Standby Time:** Click the drop-down list to set the time to enter into standby mode when no signal is detected.

**RS-232 Baud:** Select the baud rate.

You can also reboot, restore factory, export settings or import settings via clicking the corresponding buttons.

The screenshot shows a dark-themed web interface. At the top, there is a section titled "Firmware Update". It contains a "Choose File" button, the text "No file chosen", an "Update" button, and a progress bar showing 0%. Below this is a section titled "Account Passwords". It has two rows: "User" and "Admin". Each row contains three input fields: "Old Password...", "New Password...", and "Confirm Password...", followed by a "Save" button.

④ **Firmware Update:** Support update for MCU, Web and Video. Choose the update file first, and then click Update.

⑤ **Account Passwords:**

Enter the correct Old Password, New Password, and Confirm Password, and then click "Save".

**Note:** Input rules for changing passwords:

- (1) The password can't be empty.
- (2) New Password can't be the same as Old Password.
- (3) New Password and Confirm Password must be the same.

## 8. API Commands

The product also supports API command control. Connect the RS-232 port of the product to a PC. Then, open a Serial Command tool on PC to send ASCII command to control the device.

The ASCII command list is shown as below.

ASCII Command				
RS-232 Baud rate: 115200, Data bit: 8, Stop bit: 1, Parity bit: none, TCP/IP Port: 8000				
x - Parameter 1, y - Parameter 2				
Command	Function Description	Example	Feedback	Default
<b>System Setting</b>				
?	Get the list of all commands	?		List all API commands
help	Get the list of all commands	help		List all API commands
get model	Get device model	get model	HU21	
status	Get device current status	status	Please refer to the note at the end of the list.	
get version	Get firmware version	get version	BOOT: V1.00.01 MCU: V1.00.01 WEB: V1.00.01	
power on	Power on the device	power on	Power: on System initializing... Initialization finished! BOOT: V1.00.01 MCU: V1.00.01 WEB: V1.00.01	
power off	Power off the device	power off	Power: off	
get power	Get current power state	get power	Power: off	
reboot	Reboot the device	reboot	Reboot... System initializing... Initialization finished! BOOT: V1.00.01 MCU: V1.00.01 WEB: V1.00.01	

Command	Function Description	Example	Feedback	Default
<b>System Setting</b>				
reset	Reset system settings to default (Should type "yes" to confirm, "no" to discard)	reset	Sure to reset system settings to default? Type "yes" after next prompt to confirm...	
reset all	Reset system and network settings to default (Should type "yes" to confirm, "no" to discard)	reset all	Sure to reset system and network settings to default? Type "yes" after next prompt to confirm...	
set front button x	Set front button locked on/off x=0: Unlocked x=1: Locked	set front button 0	Button: unlocked	0
get front button	Get front button locked on/off status	get front button	Button: unlocked	
set hdmi power saving x	Set HDMI power saving on/off x=0: Off x=1: On	set hdmi power saving 1	HDMI power saving: on	1
get hdmi power saving	Get HDMI power saving on/off status	get hdmi power saving	HDMI power saving: on	
set auto standby time x	Set auto standby time (x=0~5) when input signal is off x=0: Never x=1: 5 min x=2: 10 min x=3: 15 min x=4: 30 min x=5: 60 min	set auto standby time 3	Auto standby time: 15 min	15 min
get auto standby time	Get auto standby time	get auto standby time	Auto standby time: 15 min	
set usbc x access network y	Set USB-C (x=0~1) access network on/off x=0: All USB-C inputs x=1: USB-C input 1 y=0: Off y=1: On	set usbc 0 access network 1 set usbc 1 access network 1	USB-C input 1 access network: on	1

Command	Function Description	Example	Feedback	Default
<b>System Setting</b>				
get usbc x access network	Get USB-C (x=0~1) access network on/off status x=0: All USB-C inputs x=1: USB-C input 1	get usbc 0 access network get usbc 1 access network	USB-C input 1 access network: on	
set gpio x value y	Set GPIO (x=0~4) value (y=1~4) x=0: All GPIOs x=1: GPIO 1 x=2: GPIO 2 x=3: GPIO 3 x=4: GPIO 4 y=1: Input (default High Level 5V) y=2: Input (default Low Level 0V) y=3: Output High Level (5V) y=4: Output Low Level (0V)	set gpio 1 value 1 set gpio 2 value 4	GPIO 1: input (default high level 5v) GPIO 2: output low level (0v)	1
get gpio x	Get GPIO (x=0~4) status x=0: All GPIOs x=1: GPIO 1 x=2: GPIO 2 x=3: GPIO 3 x=4: GPIO 4	get gpio 0	GPIO 1: low GPIO 2: high GPIO 3: low GPIO 3: high	Yes
set baud x	Set RS-232 baud rate to (x=1~6) bps x=1: 4800 x=2: 9600 x=3: 19200 x=4: 38400 x=5: 57600 x=6: 115200	set baud 6	Baudrate: 115200	115200
get baud	Get RS-232 baud rate	get baud	Baudrate: 115200	
get temp	Get device internal temperature	get temp	65C	
get uptime	Get device running time (Day:Hour:Min:Sec)	get uptime	0000:00:13:04	

Command	Function Description	Example	Feedback	Default
<b>System Setting</b>				
set auto event report x	Set auto event report on/off x=0: Off x=1: On	set auto event report 1	Auto event report: on	1
get auto event report	Get auto event report on/off status	get auto event report	Auto event report: on	
<b>Input Setting</b>				
set input x name y	Set input (x=1~2) name to y (16 characters max) x=1: USB-C input 1 x=2: HDMI input 2	set input 1 name MacBook set input 2 name Dell Laptop	USB-C input 1 name: MacBook HDMI input 2 name: Dell Laptop	USB-C In 1 HDMI In 2
get input x name	Get input (x=0~2) name x=0: All inputs x=1: USB-C input 1 x=2: HDMI input 2	get input 0 name	USB-C input 1 name: MacBook HDMI input 2 name: Dell Laptop	
get input x connected	Get input (x=0~2) cable connected status x=0: All inputs x=1: USB-C input 1 x=2: HDMI input 2	get input 0 connected	USB-C input 1: connected HDMI input 2: connected	
set input x edid y	Set input (x=0~2) EDID (y=1~20) x=0: All inputs x=1: USB-C input 1 x=2: HDMI input 2 y=1: Auto (Copy HDMI Out 1) y=2: 4K2K60_444, Audio 2CH PCM y=3: 4K2K60_444, Audio 5.1CH DTS/DOLBY y=4: 4K2K60_444, Audio 7.1CH DTS/DOLBY/HD y=5: 4K2K30_444, Audio 2CH PCM y=6: 4K2K30_444, Audio 5.1CH DTS/DOLBY	set input 0 edid 1	USB-C input 1 EDID: auto (copy HDMI out 1) HDMI input 2 EDID: auto (copy HDMI out 1)	1

Command	Function Description	Example	Feedback	Default
<b>Input Setting</b>				
set input x edid y	(Continued) y=8: 1080P60_444, Audio 2CH PCM y=9: 1080P60_444, Audio 5.1CH DTS/DOLBY y=10: 1080P60_444, Audio 7.1CH DTS/DOLBY/HD y=11: 720P60_444, Audio 2CH PCM y=12: 1920x1200, Audio 2CH PCM y=13: 1680x1050, Audio 2CH PCM y=14: 1600x1200, Audio 2CH PCM y=15: 1440x900, Audio 2CH PCM y=16: 1360x768, Audio 2CH PCM y=17: 1280x1024, Audio 2CH PCM y=18: 1024x768, Audio 2CH PCM y=19: User Defined 1 y=20: User Defined 2	set input 0 edid 1	USB-C input 1 EDID: auto (copy HDMI out 1) HDMI input 2 EDID: auto (copy HDMI out 1)	1
get input x edid	Get input (x=0~2) EDID mode x=0: All inputs x=1: USB-C input 1 x=2: HDMI input 2	get input 0 edid	USB-C input 1 EDID: auto (copy HDMI out 1) HDMI input 2 EDID: auto (copy HDMI out 1)	
set user edid x <y>	Set user defined EDID (x=1~2) x=1: User defined 1 x=2: User defined 2 y = 00 FF FF FF ..... (y is 256 bytes EDID data)	set user edid 1 <00 FF FF FF....>	User defined 1 EDID is loaded successfully	

Command	Function Description	Example	Feedback	Default
<b>Input Setting</b>				
get edid data x	Get EDID data (x=1~5) x=1: USB-C input 1 x=2: HDMI input 2 x=3: HDMI output 1 x=4: User defined 1 x=5: User defined 2	get edid data 1	USB-C input 1 EDID data <00 FF FF FF....>	
set input x hdcp y	Set input (x=0~2) HDCP on/off x=0: All inputs x=1: USB-C input 1 x=2: HDMI input 2 y=0: Off y=1: On	set input 0 hdcp 1	USB-C input 1 HDCP: on HDMI input 2 HDCP: on	1
get input x hdcp	Get input (x=0~2) HDCP on/off status x=0: All inputs x=1: USB-C input 1 x=2: HDMI input 2	get input 0 hdcp	USB-C input 1 HDCP: on HDMI input 2 HDCP: on	
<b>Output Setting</b>				
set output x name y	Set output (x=1) name to y (16 characters max) x=1: HDMI output 1	set output 1 name Sony TV	HDMI output 1 name: Sony TV	HDMI Out 1
get output x name	Get input (x=0~1) name x=0: All outputs x=1: HDMI output 1	get output 0 name get output 1 name	HDMI output 1 name: Sony TV	
get output x connected	Get output (x=0~1) cable connected status x=0: All outputs x=1: HDMI output 1	get output 0 connected get output 1 connected	HDMI output 1: connected	
set output x hdcp y	Set output (x=0~1) hdcp mode (y=1~4) x=0: All outputs x=1: HDMI output 1 y=1: Auto (follow sink) y=2: Force HDCP 1.4 y=3: Force HDCP 2.2 y=4: Signal management	set output 0 hdcp 1 set output 1 hdcp 1	HDMI output 1 HDCP: auto	1

Command	Function Description	Example	Feedback	Default
<b>Output Setting</b>				
get output x hdcp	Get output (x=0~1) hdcp mode x=0: All outputs x=1: HDMI output 1	get output 0 hdcp get output 1 hdcp	HDMI output 1 HDCP: auto	
set output x video y	Set output (x=0~1) video mode (y=1~4) x=0: All outputs x=1: HDMI output 1 y=1: Auto (auto downscale according to display's capability) y=2: Bypass y=3: Force 1080P y=4: Internal pattern	set output 0 video 1 set output 1 video 1	HDMI output 1 video: auto	1
get output x video	Get output (x=0~1) video mode x=0: All outputs x=1: HDMI output 1	get output 0 video get output 1 video	HDMI output 1 video: auto	
set output x signal y	Set output (x=0~1) signal on/off/avmute x=0: All outputs x=1: HDMI output 1 y=1: On y=2: Off y=3: AVMute	set output 0 signal 1 set output 1 signal 1	HDMI output 1 signal: on	1
get output x signal	Get output (x=0~1) signal status x=0: All outputs x=1: HDMI output 1	get output 0 signal get output 1 signal	HDMI output 1 signal: on	
get pattern	Get internal pattern generator resolution and pattern	get pattern	Pattern: 4K60Hz checkboard	
set welcome screen x	Set welcome screen function on/off x=0: Off x=1: On	set welcome screen 1	Welcome screen: on	1

Command	Function Description	Example	Feedback	Default
<b>Output Setting</b>				
set pattern x y	Set internal pattern generator resolution (x=1~7) pattern (y=1~12) x=1: 4K60Hz x=2: 4K50Hz x=3: 4K25Hz x=4: 4K24Hz x=5: 1080P60Hz x=6: 480P60Hz x=7: 576P50Hz y=1: Black y=2: Checkboard y=3: Strip y=4: Red y=5: Green y=6: Blue y=7: White y=8: Ramp y=9: Red ramp y=10: Green ramp y=11: Blue ramp y=12: PRBS	set pattern 1 2	Pattern: 4K60Hz checkboard	
get welcome screen	Get welcome screen function on/off status	get welcome screen	Welcome screen: on	
set no signal screen x	Set no signal after 60s display welcome screen function on/off x=0: Off x=1: On	set no signal screen 1	No signal screen: on	1
get no signal screen	Get no signal display welcome screen function on/off status	get no signal screen	No signal screen: on	
set image display	Set welcome screen image display	set image display	Welcome image display	
set image clear	Clear welcome screen image	set image clear	Welcome image clear	

Command	Function Description	Example	Feedback	Default
<b>Video Setting</b>				
set output x from y	Set output (x=0~1) from input (y=1~2) x=0: All outputs x=1: HDMI output 1 y=1: USB-C input 1 y=2: HDMI input 2	set output 0 from 1 set output 1 from 1	HDMI output 1: USB-C input 1	1
get output x from	Get output (x=0~1) from which input x=0: All outputs x=1: HDMI output 1	get output 0 from get output 1 from	HDMI output 1: USB-C input 1	
set output x auto switch y	Set output (x=0~1) auto switch on/off x=0: All outputs x=1: HDMI output 1 y=0: Off y=1: On	set output 0 auto switch 1 set output 1 auto switch 1	HDMI output 1 auto switch: on	on
get output x auto switch	Get output (x=0~1) auto switch on/off status x=0: All outputs x=1: HDMI output 1	get output 0 auto switch get output 1 auto switch	HDMI output 1 auto switch: on	
set output auto switch mode x	Set output auto switch detection mode (x=1~2) x=1: Input signal x=2: Source 5V	set output auto switch mode 1	Auto switch mode: input signal	1
get output auto switch mode	Get output auto switch detection mode	get output auto switch mode	Auto switch mode: input signal	
set output x fallback input y	Set output (x=0~1) fallback input source (y=1~4) when active signal is removed in single source auto switching mode x=0: All outputs x=1: HDMI output 1 y=1: Next input y=2: Previous input y=3: USB-C input 1 y=4: HDMI input 2	set output 0 fallback input 1 set output 1 fallback input 1	HDMI output 1 fallback: next input	1

Command	Function Description	Example	Feedback	Default
<b>Video Setting</b>				
get output x fallback input	Get output (x=0~1) fallback input source x=0: All outputs x=1: HDMI output 1	get output 0 fallback input get output 1 fallback input	HDMI output 1 fallback: next input	
<b>Audio Setting</b>				
set analog audio input x	Set analog audio input embedded to (x=0~2) x=0: Off x=1: USB-C input 1 x=2: HDMI input 2	set analog audio input 0	Analog audio input: off	0
get analog audio input	Get analog audio input embedded to	get analog audio input	Analog audio input: off	
set analog audio input to usb x	Set analog audio input embedded to USB audio on/off x=0: Off x=1: On	set analog audio input to usb 0	Analog audio input to USB: off	0
get analog audio input to usb	Get analog audio input embedded to USB audio on/off status	get analog audio input to usb	Analog audio input to USB: off	
set analog audio output x	Set analog audio de-embedded from (x=1~2) x=1: HDMI output 1 x=2: USB audio	set analog audio output 1	Analog audio output: HDMI output 1	1
get analog audio output	Get analog audio de-embedded from	get analog audio output	Analog audio output: HDMI output 1	
set analog audio gain x	Set analog audio gain (x=0dB ~ -50dB)	set analog audio gain -5	Analog audio gain: -5dB	0dB
get analog audio gain	Get analog audio gain value	get analog audio gain	Analog audio gain: -5dB	
set analog audio gain+ set analog audio gain+x	Increase analog audio gain +1dB Increase analog audio gain +xdB	set analog audio gain+ set analog audio gain+5	Analog audio gain: -4dB Analog audio gain: 0dB	

Command	Function Description	Example	Feedback	Default
<b>Audio Setting</b>				
set analog audio gain- set analog audio gain-x	Increase analog audio gain -1dB Increase analog audio gain -xdB	set analog audio gain- set analog audio gain-5	Analog audio gain: -6dB Analog audio gain: -10dB	
set analog audio mute x	Set analog audio mute on/off x=0: Off x=1: On	set analog audio mute 1	Analog audio mute: on	Off
get analog audio mute	Get analog audio mute status	get analog audio mute	Analog audio mute: off	
<b>USB Setting</b>				
get usb host x power	Get USB host (x=0~2) power x=0: All hosts x=1: USB-C input 1 x=2: USB host 2	get usb host power 0	USB-C input 1 power: on USB Host 2 power: off	
set usb switch mode x	Set USB switch mode (x=1~3) x=1: Follow video x=2: Manual switch x=3: Auto switch	set usb switch mode 1	USB switch mode: follow video	1
get usb switch mode	Get USB switch mode	get usb switch mode	USB switch mode: follow video	
set usb manual switch x	Set USB manual switch (x=1~2) x=1: USB-C input 1 x=2: USB host 2	set usb manual switch 1	USB manual switch: USB-C input 1	
get usb switch status	Get USB switch status	get usb switch status	USB switch status: USB-C input 1	
set usb device x power y	Set USB device (x=0~3) power mode (y=1~3) x=0: All USB device ports x=1: USB device 1 x=2: USB device 2 x=3: USB device 3 y=1: Follow host y=2: Force 5V always output y=3: Disable 5V output	set usb device 0 power	USB device 1 power: follow host USB device 2 power: follow host USB device 3 power: follow host	Follow host

Command	Function Description	Example	Feedback	Default
<b>USB Setting</b>				
get usb device x power	Get USB device (x=0~3) power mode x=0: All USB device ports x=1: USB device 1 x=2: USB device 2 x=3: USB device 3	get usb device 0 power	USB device 1 power: follow host USB device 2 power: follow host USB device 3 power: follow host	
<b>Display Control</b>				
set display x power y	Set display (x=0~1) power on/off x=0: All outputs x=1: HDMI output 1 y=0: Off y=1: On	set display 0 power 1 set display 1 power 1	Display 1 power: on	
set display x auto power feature y	Set display (x=0~1) auto power feature on/off when system power on/off x=0: All outputs x=1: HDMI output 1 y=0: Off y=1: On	set display 0 auto power feature 1 set display 1 auto power feature 1	Display 1 auto power feature: on	on
get display x auto power feature	Get display (x=0~1) auto power feature on/off status x=0: All outputs x=1: HDMI output 1	get display 0 auto power feature get display 1 auto power feature	Display 1 auto power feature: on	
set display x auto power on timer y	Set display (x=0~1) auto power on after period time (y=0~1200) when system power on x=0: All outputs x=1: HDMI output 1 y= 0~1200sec	set display 0 auto power on timer 5 set display 1 auto power on timer 5	Display 1 auto power on timer: 5 sec	5 sec
get display x auto power on timer	Get display (x=0~1) auto power on timer x=0: All outputs x=1: HDMI output 1	get display 0 auto power on timer get display 1 auto power on timer	Display 1 auto power on timer: 5 sec	

Command	Function Description	Example	Feedback	Default
<b>Display Control</b>				
set display x auto power off timer y	Set display (x=0~1) auto power off after period time (y=0~1200) when system power off x=0: All outputs x=1: HDMI output 1 y= 0~1200sec	set display 0 auto power off timer 5 set display 1 auto power off timer 5	Display 1 auto power off timer: 5 sec	5 sec
get display x auto power off timer	Get display (x=0~1) auto power off timer x=0: All outputs x=1: HDMI output 1	get display 0 auto power off timer get display 1 auto power off timer	Display 1 auto power off timer: 5 sec	
set display x control type y	Set display (x=1) power on/off control type (y[2:0]) x=1: HDMI output 1 y[0]: CEC y[1]: IR y[2]: RS-232	set display 1 control type 111	Display 1 control type: 111	100
get display x control type	Get display (x=0~1) power on/off control type x=0: All outputs x=1: HDMI output 1	get display 0 control type get display 1 control type	Display 1 control type: 111	
<b>RS-232 Setting</b>				
set serial setting y	Set serial setting to y=115200-8n1 Baud rate: 115200/57600/5600 0/38400/19200/9600/4800/2400 Data bits: 7/8 Parity: n(None)/ o(Odd) / e(Even) Stop bits: 1/2	set serial setting 115200-8n1	Serial setting: 115200-8n1	115200-8n1
get serial setting	Get serial setting	get serial setting	Serial setting: 115200-8n1	
set serial HEX/ASCII <end> <command>	Set serial general command, command format is HEX or ASCII <end>= command end flag, can be null/CR/LF/CR+LF <command>= RS-232 command	set serial ASCII <CR+LF> <VOL+>	Serial: ASCII <CR+LF> <VOL+>	

Command	Function Description	Example	Feedback	Default
<b>RS-232 Setting</b>				
set serial power on/off HEX/ASCII <end> <command1> <delay> <command2>	Set serial power on/off commands, command format is HEX or ASCII <end>= command end flag, can be null/CR/LF/CR+LF <command1>= RS-232 power on/off command 1 <delay>= 0~1200sec <command2>= RS-232 power on/off command 2 NOTE: <delay> and <command2> can be NULL	set serial power on ASCII <CR+LF> <PWRON> <10> <INPUT1> set serial power off ASCII <CR+LF> <PWROFF> <10> <LAMPOFF> set serial power on ASCII <CR+LF> <PWRON> set serial power off ASCII <CR+LF> <PWROFF> set serial power on HEX <null> <11 22> set serial power off HEX <null> <33 44>	Serial power on: ASCII <CR+LF> <PWRON> <10> <INPUT1> Serial power off: ASCII <CR+LF> <PWROFF> <10> <LAMPOFF> Serial power on: ASCII <CR+LF> <PWRON> Serial power off: ASCII <CR+LF> <PWROFF> Serial power on: HEX <null> <11 22> Serial power off: HEX <null> <33 44>	
get serial power on/off command	Get serial power on/off commands	get serial power on command get serial power off command	Serial power on: ASCII <CR+LF> <PWRON> <10> <INPUT1> Serial power off: ASCII <CR+LF> <PWROFF> <10> <LAMPOFF> Serial power on: ASCII <CR+LF> <PWRON> Serial power off: ASCII <CR+LF> <PWROFF> Serial power on: HEX <null> <11 22> Serial power off: HEX <null> <33 44>	
<b>IR Setting</b>				
set ir power on/off	Set IR power on/off	set ir power on set ir power off	IR power: on IR power: off	

Command	Function Description	Example	Feedback	Default
<b>CEC Setting</b>				
set input x cec <y>	Set input (x=0, x=2) CEC command <y> x=0: All inputs x=2: HDMI input 2 y=power on/power off y=menu/select/up/down/ left/right/exit y=play/stop/pause/ rewind/fast forward/ previous/next y=volume up/volume down/mute	set input 0 cec <power on> set input 2 cec <power on>	HDMI input 2 CEC: power on	
set input x custom cec <y>	Set input (x=0, x=2) custom CEC command <y> x=0: All inputs x=2: HDMI input 2 y=custom CEC command (hex format)	set input 0 custom cec <87 01> set input 1 custom cec <87 01>	HDMI input 2 CEC: <87 01>	
set output x cec <y>	Set output (x=0~1) CEC command <y> x=0: All outputs x=1: HDMI output 1 y=power on/power off y=active source/image view on/text view on y=volume up/volume down/mute	set output 0 cec <power off> set output 1 cec <power off>	HDMI output 1 CEC: power off	
set output x custom cec <y>	Set output (x=0~1) custom CEC command <y> x=0: All outputs x=1: HDMI output 1 y=custom CEC command (hex format)	set output 0 custom cec <87 01> set output 1 custom cec <87 01>	HDMI output 1 CEC: <87 01>	

Command	Function Description	Example	Feedback	Default
<b>Preset Setting</b>				
set preset save x	Save the current unit's settings to the specified preset (x=1~5) All settings except network setting. x=1~5: Preset 1 ~ Preset 5	set preset save 1	Preset 1: save	
set preset recall x	Recall a specified preset into unit (x=1~5) All settings except network setting. x=1~5: Preset 1 ~ Preset 5	set preset recall 1	Preset 1: recall	
set preset clear x	Clear a specified preset into unit (x=1~5) All settings except network setting. x=1~5: Preset 1 ~ Preset 5	set preset clear 1	Preset 1: clear	
set preset x name y	Set preset (x=1~5) name to y (16 characters max) x=1~5: Preset 1 ~ Preset 5	set preset 1 name MeetingRoom 1	Preset 1 name: MeetingRoom 1	
get preset x name	Get preset (x=1~5) name x=1~5: Preset 1 ~ Preset 5	get preset 1 name	Preset 1 name: MeetingRoom 1	
<b>Network Setting</b>				
get mac addr	Get network MAC address	get mac addr	MAC address: 6C:DF:FB:0C:B3:8E	
set ip mode x	Set network IP mode to static IP or DHCP (x=0~1) x=0: Static x=1: DHCP	set ip mode 0	IP mode: static (Please use "set net reboot" command to apply new config!)	1

Command	Function Description	Example	Feedback	Default
<b>Network Setting</b>				
get ipconfig	Get the Current IP Configuration	get ipconfig	IP mode: DHCP IP address: 192.168.62.106 Subnet mask: 255.255.255.0 Gateway: 192.168.62.1 TCP/IP port: 8000 Telnet port: 23 MAC address: 6C:DF:FB:0C:B3:8E (Static: 169.254.100.200 255.255.0.0 169.254.100.1)	default static IP is 192.168.0. 100/255.2 55.0.0/192 .168.0.1
get ip mode	Get network IP mode	get ip mode	IP mode: static	
set ip addr xxx.xxx.xxx. xxx	Set network IP address	set ip addr 192.168.1.100	IP address: 192.168.1.100 (Please use "set net reboot" command to apply new config!) DHCP on, device can't config static address, set DHCP off first.	
get ip addr	Get network IP address	get ip addr	IP address: 192.168.1.100	
set subnet xxx.xxx.xxx. xxx	Set network subnet mask	set subnet 255.255.255.0	Subnet mask: 255.255.255.0 (Please use "set net reboot" command to apply new config!) DHCP on, device can't config subnet mask, set DHCP off first.	

Command	Function Description	Example	Feedback	Default
<b>Network Setting</b>				
get subnet	Get network subnet mask	get subnet	Subnet mask: 255.255.255.0	
set gateway xxx.xxx.xxx. xxx	Set network gateway	set gateway 192.168.1.1	Gateway: 192.168.1.1 (Please use "set net reboot" command to apply new config!) DHCP on, device can't config gateway, set DHCP off first.	
get gateway	Get network gateway	get gateway	Gateway: 192.168.1.1	
set tcp/ip x	Set network TCP/IP port on/off x=0: Off x=1: On	set tcp/ip 1	TCP/IP port: on	1
get tcp/ip	Get network TCP/IP port on/off status	get tcp/ip	TCP/IP port: on	
set tcp/ip port x	Set network telnet port(x=1~65535)	set tcp/ip port 8000	TCP/IP port: 8000	8000
get tcp/ip port	Get network TCP/IP port	get tcp/ip port	TCP/IP port: 8000	
set telnet x	Set network telnet port on/off x=0: Off x=1: On	set telnet 1	Telnet port: on	1
get telnet	Get network telnet port on/off status	get telnet	Telnet port: on	
set telnet port x	Set network telnet port(x=1~65535)	set telnet port 23	Telnet port: 23	23
get telnet port	Get network telnet port	get telnet port	Telnet port: 23	
set net hostname xxxx	Set network hostname to xxxx (x={32 characters max})	set net hostname xxxx	Hostname: 1234	HU21+ (Mac{3}%16, Mac{4}, Mac{5})
get net hostname	Get network hostname	get net hostname	Hostname: 1234	

Command	Function Description	Example	Feedback	Default
<b>Network Setting</b>				
set net reboot	Reboot network modules	set net reboot	Network reboot... Search for IP, Please wait ...! IP mode: DHCP IP address: 192.168.62.106 Subnet mask: 255.255.255.0 Gateway: 192.168.62.1 TCP/IP port: 8000 Telnet port: 23 MAC address: 6C:DF:FB:0C:B3:8E (Static: 169.254.100.200 255.255.0.0 169.254.100.1)	
set net mode x	Set network working mode (x=1~2) x=1: Mode 1 (separated mode), LAN 1 is for TCP/IP and Web GUI access, LAN 2 is for 1G ethernet. x=2: Mode 2 (switch mode), LAN 1 and LAN 2 both can access TCP/IP and Web GUI and 1G ethernet.	set net mode 1	Network mode: 1	1
get net mode	Get network working mode	get net mode	Network mode: 1	
<b>Password Setting</b>				
set admin password x	Set admin login password (x=[16 characters max])	set admin password 1234	Admin password: 1234	1234
get admin password	Get admin login password	get admin password	Admin password: 1234	
set user password x	Set user login password (x=[16 characters max])	set user password 1234	User password: 1234	1234
get user password	Get user login password	get user password	User password: 1234	

Note: The feedback of the command of "status" is as following.

=====  
Status Info HU21

MCU: V1.00.06 WEB: V2.00.06

**Power Key Baud WelcomeScreen NoSignalScreen HDMIPowerSaving**

On On 15200 On On On

**AutoSwitch\_Mode AutoStandbyTime UsbcAccessNetwork Temp(C) Uptime(Day:Hour:Min:Sec)**

Input\_Signal 5min USB-C 1 49 0000:00:19:07

**Input Name Cable Resolution ColorSpace ColorDepth HDCP**

USB-C\_In1 USB-C In 1 Connected 3840x2160p59.94 RGB 8 Off

HDMI\_In2 HDMI In 2 Disconnected None None None Off

**EDID**

Auto (Copy HDMI Out 1)

Auto (Copy HDMI Out 1)

**Output Name Cable Resolution ColorSpace ColorDepth HDCP**

HDMI\_Out1 HDMI Out 1 Connected 3840x2160p59.94 RGB 8 Off

**VideoMode OutputSignal AutoSwitch From**

Auto On On USB-C\_In1

**Analog\_Audio\_In Analog\_Audio\_In\_To\_USB Analog\_Audio\_Out\_From**

Off On HDMI\_Out1

**Analog\_Audio\_Out\_Mute Analog\_Audio\_Out\_Gain**

Off 0dB

**USB\_Switch USB-C\_In1 USB\_Host2 USB\_Device1 USB\_Device2 USB\_Device3**

Follow Video Power Off Power Off Follow Host Follow Host Force 5V Always Out

**Display\_AutoPower On/Off Power\_On\_Time(s) Power\_Off\_Time(s) Control\_Mode**

HDMI\_Out1 On 5 5 CEC

**GPIO1 GPIO2 GPIO3 GPIO4**

Input\_High Input\_High Input\_High Input\_High

**TCP/IP TCP/IP\_Port Telnet Telnet Port MAC**

On 8000 On 0023 6C:DF:FB:07:4D:4C

**DHCP IP Gateway SubnetMask**

On 169.254.100.106 255.255.255.000 169.254.100.001

(Static: 192.168.000.100 255.255.000.000 192.168.000.001)

## 9. Application Example

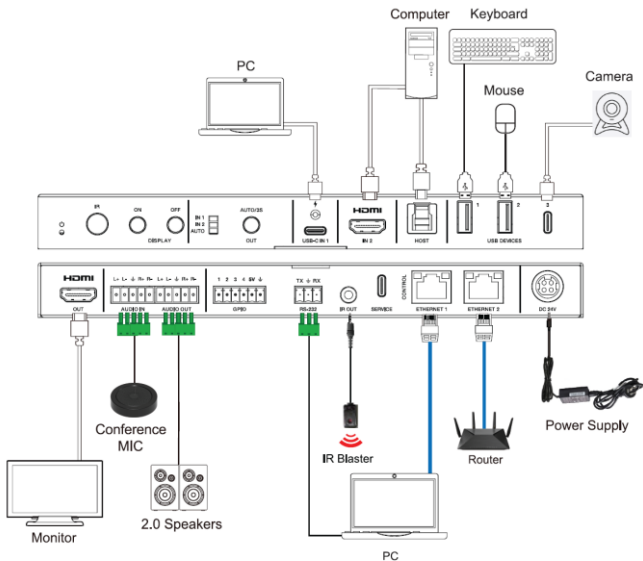

**Mode 1 (separated mode):** LAN 1 = TCP/IP/Web GUI, LAN 2 = 1G Ethernet only

**Mode 2 (switch mode):** LAN 1 and LAN 2 = TCP/IP/Web GUI and 1G Ethernet

**HDMI™**  
HIGH-DEFINITION MULTIMEDIA INTERFACE

The terms HDMI, HDMI High-Definition Multimedia Interface, HDMI trade dress and the HDMI Logos are trademarks or registered trademarks of HDMI Licensing Administrator, Inc.

# DVDO

Follow us

