



# USER MANUAL

## MODEL:

**MTX3-88-HSA**

**4K HDMI 8x8 Matrix Switcher**

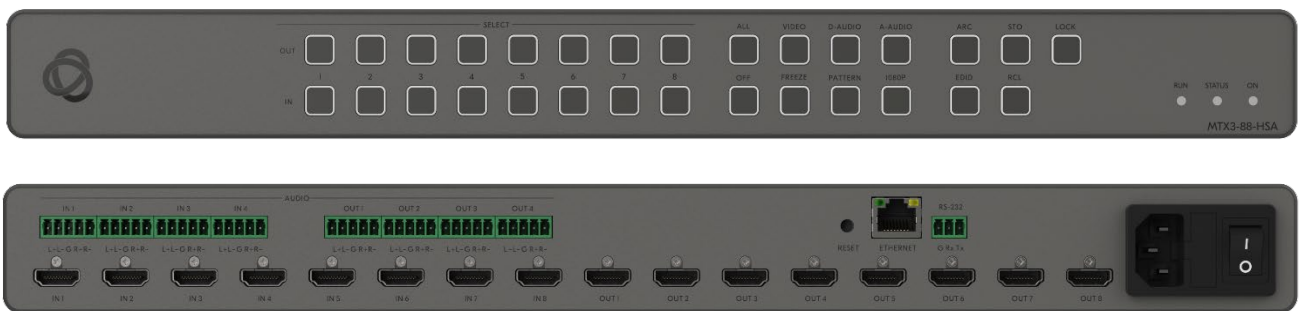

# Contents

<b>Introduction</b>	<b>1</b>
Getting Started	1
Overview	2
Typical Applications	3
<b>Defining MTX3-88-HSA 4K HDMI 8x8 Matrix Switcher</b>	<b>4</b>
<b>Mounting MTX3-88-HSA</b>	<b>6</b>
<b>Connecting MTX3-88-HSA</b>	<b>7</b>
Connecting a Balanced/Unbalanced Stereo Audio Source to the Balanced Input	8
Connecting to MTX3-88-HSA via RS-232	9
<b>Operating MTX3-88-HSA via Front Panel Buttons</b>	<b>10</b>
Routing Signals	11
Turning OFF Selected or All Video Outputs	14
Routing a Pattern to the Output	15
Operating in ARC Mode	16
Storing and Recalling a Setup	16
Switching Modes	18
Copying EDID	18
Operating via Ethernet	19
<b>Using Embedded Web Pages</b>	<b>23</b>
Routing	24
AV Routing	25
Presets	27
AV Settings	30
Video Wall	37
Managing EDID	40
Setting CEC Gateway Properties	41
Setting Device Properties	44
Security	50
Diagnostics	55
<b>Upgrading Firmware with RS-232</b>	<b>56</b>
<b>Technical Specifications</b>	<b>57</b>
Default Communication Parameters	58
<b>Protocol 3000</b>	<b>59</b>
Understanding Protocol 3000	59
Protocol 3000 Commands	60
Result and Error Codes	74

# Introduction

Welcome to Kramer Electronics! Since 1981, Kramer Electronics has been providing a world of unique, creative, and affordable solutions to the vast range of problems that confront the video, audio, presentation, and broadcasting professional on a daily basis. In recent years, we have redesigned and upgraded most of our line, making the best even better!

---

## Getting Started

We recommend that you:

- Unpack the equipment carefully and save the original box and packaging materials for possible future shipment.
- Review the contents of this user manual.



Go to <http://www.kramerav.com/downloads/MTX3-88-HSA> to check for up-to-date user manuals, application programs, and to check if firmware upgrades are available (where appropriate).

## Achieving Best Performance

- Use only good quality connection cables (we recommend Kramer high-performance, high-resolution cables) to avoid interference, deterioration in signal quality due to poor matching, and elevated noise levels (often associated with low quality cables).
- Do not secure the cables in tight bundles or roll the slack into tight coils.
- Avoid interference from neighboring electrical appliances that may adversely influence signal quality.
- Position your Kramer **MTX3-88-HSA** away from moisture, excessive sunlight and dust.

## Safety Instructions



### Caution:

- This equipment is to be used only inside a building. It may only be connected to other equipment that is installed inside a building.
- For products with relay terminals and GPIO ports, please refer to the permitted rating for an external connection, located next to the terminal or in the User Manual.
- There are no operator serviceable parts inside the unit.



### Warning:

- Use only the power cord that is supplied with the unit.
- Disconnect the power and unplug the unit from the wall before installing.
- Do not open the unit. High voltages can cause electrical shock! Servicing by qualified personnel only.
- To ensure continuous risk protection, replace fuses only according to the rating specified on the product label which is located on the bottom of the unit.

## Recycling Kramer Products

The Waste Electrical and Electronic Equipment (WEEE) Directive 2002/96/EC aims to reduce the amount of WEEE sent for disposal to landfill or incineration by requiring it to be collected and recycled. To comply with the WEEE Directive, Kramer Electronics has made arrangements with the European Advanced Recycling Network (EARN) and will cover any costs of treatment, recycling and recovery of waste Kramer Electronics branded equipment on arrival at the EARN facility. For details of Kramer's recycling arrangements in your particular country go to our recycling pages at <https://www.kramerav.com/social-responsibility/environment/>.

---

## Overview

Congratulations on purchasing your Kramer **MTX3-88-HSA**.

MTX3-88-HSA is a high-quality scaler-based matrix with eight HDMI inputs independently routable to eight HDMI outputs. The video scaling processor provides a fast and clean (1sec) switching time. Each HDMI output supports down or up scaling to account for any sink / source capability difference. The integrated audio matrix, with four analog audio input and four analog audio output ports supports routing of any digital or analog audio sources to sinks, including ARC (Audio Return Channel) sources.

## Exceptional Quality

- Flexible and Safe Matrix Routing — Clean and fast switching between inputs, with smooth and safe transition between presented content on displays, for convenient presentation experience of end-users.
- HDMI Signal Switching — HDCP 2.3 compliant, supporting deep color, ARC, up to 7.1 uncompressed audio channels, and 3D, as specified in HDMI 2.0b.
- I-EDIDPro™ Kramer Intelligent EDID Processing™ — Individual EDID management per input for flexibly capturing and storing EDID from output-connected displays or custom files. Intelligent EDID handling and processing ensures plug & play operation for HDMI source and display systems.
- Splash screens support – up to 16 pre-loaded images can be selected to any HDMI output. This provides a simple implementation of useful features like room welcome screens, emergency announcement screens and more.
- IP Gateway support – CEC control messages to sinks or sources as well as GPIO control messages may be defined and generated using the IP control gateway mechanism.

## Advanced and User-friendly Operation

- Auto Switcher Ease of Use — Automatically switches source signals to the connected displays according to user-configured preferences, such as priority or last-connected input.
- Multiview support – each HDMI output can display content from two inputs in several layouts including picture-in-picture and side-by-side.
- Supports legacy controllers using RS-232 protocol with P3K API commands.

- Simple and intuitive integrated backlit panel buttons allow operating the device manually.
- Simple Control — Remote IP–controller connection, browser operation webpage, or local panel buttons, and multiple preset configurations, for easy and fully flexible user ports selection, signals routing, and matrix control.
- Secured Web-UI Operation — User credentials authentication for secured web-UI access and operation.

## Flexible Connectivity

- Independent Audio Breakaway and Routing — The digital audio signals passing through to the selectable outputs, and ARC (Audio Return Channel) signals from the output-connected displays, are extracted, converted to analog audio signals, and input to the built-in audio matrix. Flexible matrix routing enables insertion of any audio input signal, either the breakaway input signals or from the matrix input ports, to any AV matrix output port or audio matrix analog balanced ports. This allows playing the audio on a locally connected professional audio system (such as DSP) and speakers, in parallel to playing it on the speakers connected to the AV acceptor devices (such as TVs with speakers).
- Comprehensive Management — Local panel–button operation, remote IP–driven firmware upgrade and management via user–friendly embedded web pages, built-in test video patterns for outputs and displays diagnostics, and remote IP or local serial service and management via API commands and responses communication, for flexible service options and ensure lasting, field proven deployment.
- Easy and Elegant Installation — 19” enclosure for rack mounting in a 1U rack space with included rack ears and universal 100–240V AC power supply.

---

## Typical Applications

The **MTX3-88-HSA** is ideal for the following typical applications:

- Small to medium sized conference / lecture or training spaces
- Hotel lobbies
- Museums and experience centers

## Controlling your MTX3-88-HSA

Control your **MTX3-88-HSA** directly via the front panel push buttons, or:

- By RS-232 serial commands transmitted by a touch screen system, PC, or other serial controller.
- Via the Ethernet using built-in user-friendly Web pages.

# Defining MTX3-88-HSA 4K HDMI 8x8 Matrix Switcher

This section defines MTX3-88-HSA.

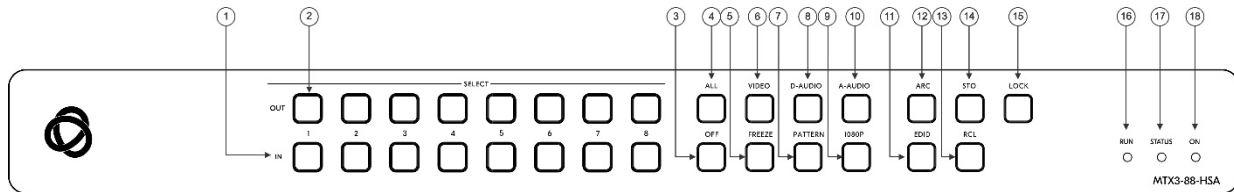

Figure 1: MTX3-88-HSA 4K HDMI 8x8 Matrix Switcher Front Panel

#	Feature	Function	
①	IN (SELECTOR) Buttons	Press to select the input (1 to 8) to switch after selecting an output.	
②	OUT (SELECTOR) Buttons	Press to select an output (1 to 8) to which the input is routed. Also used for storing machine presets.	
③	OFF Button	Press after pressing an output button to disconnect the selected output from the inputs. To disconnect all the outputs, press ALL followed by OFF.	
④	ALL Button	For switching, press ALL and then a specific IN button to route the selected input to all outputs. For example, press ALL and then IN 2 to route input 2 to all the outputs. Press to perform an action on all outputs (for example setting Pattern mode).	
⑤	FREEZE Button	Press to freeze/unfreeze a display.	
⑥	VIDEO Button	Press to select video inputs. When pressed together with D-AUDIO/A-AUDIO, video is switched together with audio.	
⑦	PATTERN Button	Press the PATTERN button, followed by an OUT button to route a pattern to the selected output.	
⑧	D-AUDIO Button	Press to enable digital audio routing. When pressed together with VIDEO, the digital audio is routed together with the video signal.	
⑨	1080P Button	Press OUT button, followed by 1080P button to set the Out resolution to 1080P.	
⑩	A-AUDIO Button	Press to enable analog audio routing. When pressed together with VIDEO, the analog audio is routed together with the video signal.	
⑪	EDID Button	Press to capture the EDID of the currently selected output to its input source.	
⑫	ARC Button	Press ARC, an input button, and then an output button. The selected output port sources its ARC to the selected input port ARC.	
⑬	RCL Button	Press to recall the switch setting from a preset, followed by pressing the output button of the required previously stored preset.	
⑭	STO Button	Press to store the current switching setting to a preset, followed by pressing an output button (for 1 to 8 presets).	
⑮	LOCK Button	Press and hold to toggle locking/releasing of the front panel buttons.	
⑯	RUN LED	<b>LED Status</b>	<b>Indicates</b>
		Lights green	The device is working properly
		Flashes red	Switching or internal operation execution
		<b>LED Status</b>	<b>Indicates</b>

#	Feature	Function	
17	STATUS LED (Status Alarm)	Flashes red	The temperature, voltage, or fan is not working properly.
		Lights green	The device is working properly.
18	ON LED	<b>LED Status</b>	<b>Indicates</b>
		Lights green	Power is supplied to device

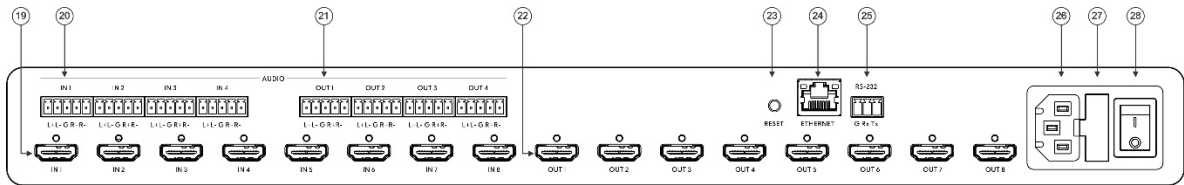

Figure 2: MTX3-88-HSA 4K HDMI 8x8 Matrix Switcher Rear Panel

#	Feature	Function
19	IN HDMI Connectors	Connect to HDMI sources (from 1 to 8).
20	AUDIO IN on Balanced 5-pin Terminal Block Connectors	Connect to unbalanced stereo analog audio sources (from 1 to 4).
21	AUDIO OUT on 5-pin Terminal Block Connectors	Connect to balanced stereo analog audio acceptor (from 1 to 4).
22	OUT HDMI Connectors	Connect to HDMI acceptors (from 1 to 8).
23	RESET Button	<ul style="list-style-type: none"> <li>Press and hold for 5 seconds; The device performs a factory reset and restarts.</li> <li>Short press: The device restarts.</li> </ul>
24	ETHERNET RJ-45 Port	Connect to your LAN.
25	RS-232 3-pin Terminal Block Connectors	Connect to a PC or a serial controller.
26	Mains Power Connector	Connect to the mains power.
27	Mains Power Fuse	Fuse for protecting the device.
28	Mains Power Switch	Switch for turning the device on or off.

# Mounting MTX3-88-HSA

This section provides instructions for mounting **MTX3-88-HSA**. Before installing, verify that the environment is within the recommended range:



- Operation temperature – 0° to 40°C (32 to 104°F).
- Storage temperature – -40° to +70°C (-40 to +158°F).
- Humidity – 10% to 90%, RHL non-condensing.

**Caution:**

- Mount **MTX3-88-HSA** before connecting any cables or power.

**Warning:**

- Ensure that the environment (e.g., maximum ambient temperature & air flow) is compatible for the device.
- Avoid uneven mechanical loading.
- Appropriate consideration of equipment nameplate ratings should be used for avoiding overloading of the circuits.
- Reliable earthing of rack-mounted equipment should be maintained.

**Mount MTX3-88-HSA in a rack:**

- To rack mount the machine, attach both rack ears (by removing the screws from each side of the machine and replacing those screws through the rack ears) or place the machine on a table.

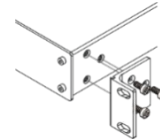

# Connecting MTX3-88-HSA

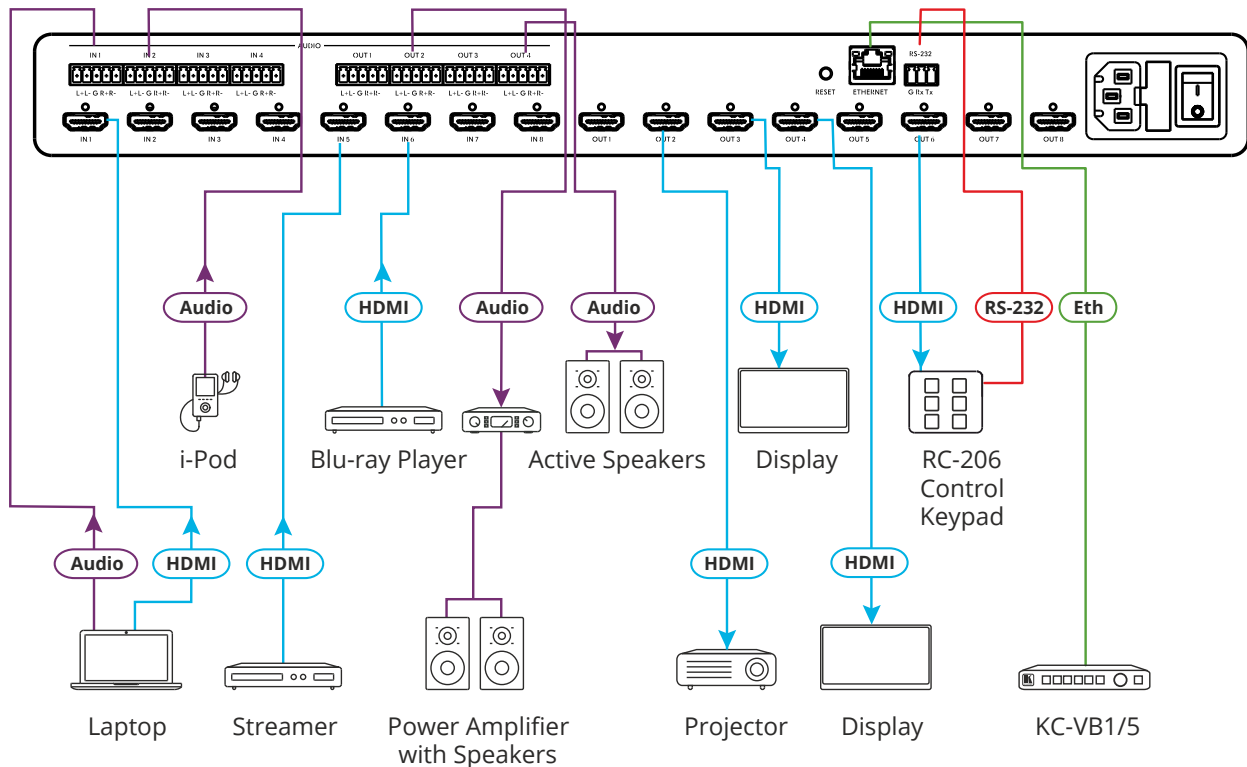

Figure 3: Connecting to the MTX3-88-HSA Rear Panel

To connect MTX3-88-HSA as illustrated in the example in [Figure 3](#):

- Connect up to eight video sources to the HDMI INPUT connectors <sup>(19)</sup> (from INPUT 1 to INPUT 8). For example, connect:
  - A laptop to IN 1.
  - A Streamer to IN 5.
  - Blu-ray player to IN 6.
- Connect up to four analog stereo audio sources to the AUDIO IN <sup>(20)</sup> (from IN 1 to IN 4). For example, connect:
  - The analog audio output of a laptop to AUDIO IN 1.
  - An I-Pod to AUDIO IN 2.
- Connect the eight video HDMI OUTPUT connectors <sup>(22)</sup> (from OUTPUT 1 to OUTPUT 8) to up to eight acceptors. For example, connect:
  - OUTPUT 2 to a projector.
  - OUTPUT 3, OUTPUT 4 and OUTPUT 6 HDMI each to a display.
- Connect the four balanced analog output 5-pin terminal block connectors <sup>(21)</sup> (from OUT 1 to OUT 4) to up to four audio acceptors. For example, connect:
  - OUTPUT 2 to a power amplifier with speakers.

- OUTPUT 4 to active speakers.
5. If required, connect:
- The ETHERNET port (24) to a control device (in [Figure 3](#), KC-VB 1/5).
  - The RS-232 port (25) to a controlled device (in [Figure 3](#), TV monitor).
6. Connect the power cord to the power connector (26) and to the mains electricity (not shown in [Figure 3](#)).
- We recommend that you use only the power cord that is supplied with this machine.

---

## Connecting a Balanced/Unbalanced Stereo Audio Source to the Balanced Input

The following are the pinouts for connecting the output to a balanced or unbalanced stereo audio acceptor:

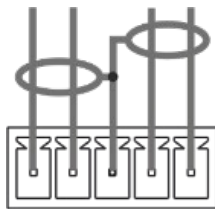

L+ L- G R+ R-

Figure 4: Connecting to a Balanced Stereo Audio Acceptor

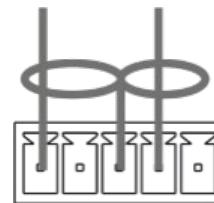

L+ L- G R+ R-

Figure 5: Connecting to an Unbalanced Stereo Audio Acceptor

## Connecting to MTX3-88-HSA via RS-232

You can connect to **MTX3-88-HSA** via an RS-232 connection (25) using, for example, a PC.

**MTX3-88-HSA** features an RS-232 3-pin terminal block connector allowing the RS-232 to control **MTX3-88-HSA**.

Connect the RS-232 terminal block on the rear panel of **MTX3-88-HSA** to a PC/controller, as follows:

From the RS-232 9-pin D-sub serial port connect:

- Pin 2 to the TX pin on the **MTX3-88-HSA** RS-232 terminal block
- Pin 3 to the RX pin on the **MTX3-88-HSA** RS-232 terminal block
- Pin 5 to the G pin on the **MTX3-88-HSA** RS-232 terminal block

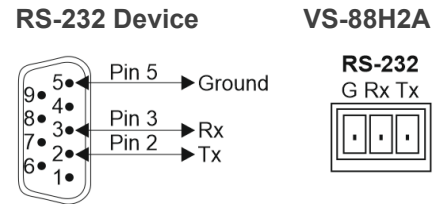

# Operating MTX3-88-HSA via Front Panel Buttons

Press the power switch to power the device. The device enters a self-checking state, and then initialization begins.

During the 10-second initialization process, the:

- All of the keyboard indicators are fully illuminated for a short time.
- The RUN and STATUS LED indicator lights change from red to green.
- The indicator lights turn off.

Following initialization, the front panel buttons enter normal operation:

- The **IN** button indicator light indicates the active signal connected to the input.
- The **OUT** button indicator indicates that the receiver is connected to the output.

Following initialization, the front panel buttons enter normal operation:

- The **IN** button indicator light indicates the active signal connected to the input.
- The **OUT** button indicator indicates that the receiver is connected to the output.

In general, the front panel buttons indicate the device operation modes follows:

Button	LED Status	Operation Mode
Press VIDEO	On	Pressing an output button will light the input which it is routed from. Pressing a different input button will modify the routing. Video inputs are switched to video outputs.
Press D-AUDIO	On	Pressing an output will light the digital audio input which it is routed to. Pressing a different input button will modify the routing of the digital audio. Digital inputs (HDMI input audio) are switched to digital outputs (HDMI output audio). If after pressing the output button, no input is lit on, this indicates that an analog input audio is routed to this video digital output.
Press twice D-AUDIO	Flashing	Pressing an input button followed by an output button routes analog Audio inputs and embeds : Analog audio inputs are switched to the digital audio outputs (HDMI output audio).
A-AUDIO	On	Audio de-embedding: Digital audio outputs (HDMI input audio) are switched to Analog audio outputs.
Press twice A-AUDIO	Flashing	Pressing input button following output button routes Analog digital audio inputs are switched to analog audio outputs.
VIDEO	On	Video and digital inputs (HDMI) are switched to video and digital audio outputs (HDMI).
D-AUDIO	On	
VIDEO	On	Video inputs (HDMI) are switched to video outputs and analog audio inputs (AUDIO IN) are switched to digital audio outputs (HDMI).
A-AUDIO	On	

MTX3-88-HSA front panel buttons enable performing the following functions:

- [Routing Signals](#) on page [11](#).
- [Turning OFF Selected or All Video Outputs](#) on Page [14](#).
- [Routing a Pattern to the Output](#) on Page [15](#).
- [Operating in ARC Mode](#) on Page [16](#).
- [Storing and Recalling a Setup](#) on Page [16](#).
- [Switching Modes](#) on Page [18](#).
- [Copying EDID](#) on Page [18](#).

---

## Routing Signals

You can switch the video and the audio signals together (AFV) or switch them separately, via the following switching modes:

- [Switching the Video Signal](#) on page [11](#).
- [Routing Analog Audio](#) on page [12](#).
- [Routing an Audio Input to the Digital HDMI Output](#) on page [12](#).
- [Switching Video and Audio Signal Simultaneously](#) on page [13](#).

## Switching the Video Signal

The **VIDEO** button on the **MTX3-88-HSA** front panel enables video routing.



On the front panel buttons:

- An illuminated input button means that an active signal is detected on that input.
- An illuminated output button means that a display is connected to that output.
- A flashing output button means that a non-HDCP display is connected to that output.

**To switch a video input to an output:**

1. Press **VIDEO**.  
The button illuminates.
2. Press **OUT** button. The button illuminates and shows the current output port video status.



On the front panel buttons:

- If the corresponding source of the output is HDMI input, the corresponding IN button light is ON.
  - If the output is off, the OFF button light is ON.
  - If the output is pattern, the PATTERN button is ON.
2. Press the corresponding **IN / OFF / PATTERN / FREEZE** button; the corresponding button illuminates and the output is immediately switched to the corresponding channel.



Press **ALL** (instead of an output button) to route the selected input to all the outputs.

## Routing Analog Audio

The **A-AUDIO** button on the **MTX3-88-HSA** front panel enables to route either the analog audio input signals or the HDMI embedded audio signals to the balanced stereo analog audio outputs.

### To switch an HDMI digital audio input to an analog output:

1. Press twice **A-Audio** button.  
The button flashes (HDMI audio input to balanced audio output mode).
2. While **A-AUDIO** flashes, select an OUT button. The button illuminates (OUT 5 ~ OUT 8 button/light is not valid).



If the signal source of this channel audio is from HDMI audio, the corresponding HDMI IN button illuminates.

3. Press the corresponding **IN 1~IN 8** button, or the OFF button, and switch the output to the corresponding channel immediately.

When switching you can also press:

- **ALL** (instead of an output button) and then an input button to route the selected input to all the outputs.

### To switch an analog audio input to an analog output:

1. Press **A-AUDIO** button. The button illuminates (OUT 5 ~ OUT 8 button/light is not valid).
2. While **A-AUDIO** is ON, select an OUT button (for example, 3) and then an IN button (for example, 4). Analog input 4 is routed to balanced stereo audio output 3.

When switching you can also press:

- **ALL** (instead of an output button) and then an input button to route the selected input to all the outputs.

## Routing an Audio Input to the Digital HDMI Output

The **D-AUDIO** button on the **MTX3-88-HSA** front panel enables to route either the analog audio input signals or the HDMI embedded audio signals to the HDMI outputs.

Generally, digital routing is enabled by pressing **D-AUDIO**:

- When it is illuminated, the HDMI input embedded audio is the audio source.
- When it flashes, the analog audio input is the audio source.

### To switch an HDMI audio input to a digital output:

1. Press **D-AUDIO**.

2. While **D-AUDIO** is on, select an OUT button. The button illuminates.



If the signal source of this channel audio is from HDMI audio, the corresponding HDMI IN button illuminates.

3. Press the corresponding IN button, or the OFF button, and switch the output to the corresponding channel immediately.

When switching you can also press:

- **ALL** (instead of an output button) and then an input button to route the selected input to all the outputs.

#### To switch an analog audio input to a digital output:

1. Press **D-AUDIO** twice.  
The button flashes (analog audio input to HDMI output mode).
2. While **D-AUDIO** flashes, select an OUT button. The button illuminates.  
If the signal source of this channel audio comes from analog audio, the corresponding HDMI IN button is on; otherwise, all HDMI IN buttons are not illuminated.
3. Press the corresponding **IN 1 ~ IN 4** button, or the OFF button, and switch the output to the corresponding channel immediately.

When switching you can also press:

- **ALL** (instead of an output button) and then an input button to route the selected input to all the outputs.

## Switching Video and Audio Signal Simultaneously

You can select the digital audio signal to switch to the output together with the video signal.

#### To switch the audio and video signals together to an output:

1. Press **D-AUDIO** and **VIDEO** simultaneously.  
The buttons illuminate. The buttons light with the input signal and output lights on.
2. Press an **OUT SELECTOR** Button (1 to 8).  
The button illuminates. The IN button light corresponds to the current video switch.



Press the **ALL** Button (instead of an output button) to route the selected input to all the outputs.

3. Press an IN (1 to 8), or OFF button. The selected video and audio input is switched to the selected output (or to all the outputs if **ALL** was pressed instead).

## Switching Video and Analog Audio Signal Simultaneously

You can select the analog audio signal to switch to the output together with the video signal.

#### To switch the analog audio and video signals together to an output:

1. Press **A-AUDIO** and **VIDEO** simultaneously.  
The buttons illuminate. The buttons light with the input signal and output lights on.

2. Press an **OUT SELECTOR** Button (1 to 8).

The button illuminates. The IN button light corresponds to the current video switch.



Press the **ALL** Button (instead of an output button) to route the selected input to all the outputs.

3. Press an IN button, or OFF button. The selected video and audio input is switched to the selected output (or to all the outputs if **ALL** was pressed instead).

---

## Turning OFF Selected or All Video Outputs

You can turn OFF the video output for a specific output or for all outputs.

### To turn OFF a video output:

1. Press the **OFF** button followed by an Output button.  
The selected video output is now off.

### To turn OFF all video outputs:

1. Press the **OFF** button followed by the **ALL** button.  
All video outputs are now OFF.

### To turn ON all video outputs:

1. When all Video outputs are OFF, Press the **OFF** button followed by the **ALL** button.  
All video outputs are now ON.

## Routing a Pattern to the Output

MTX3-88-HSA generates 8 embedded patterns. These patterns can be routed to any of the outputs.



- Once a pattern is selected, that same pattern is routed to all the selected outputs.

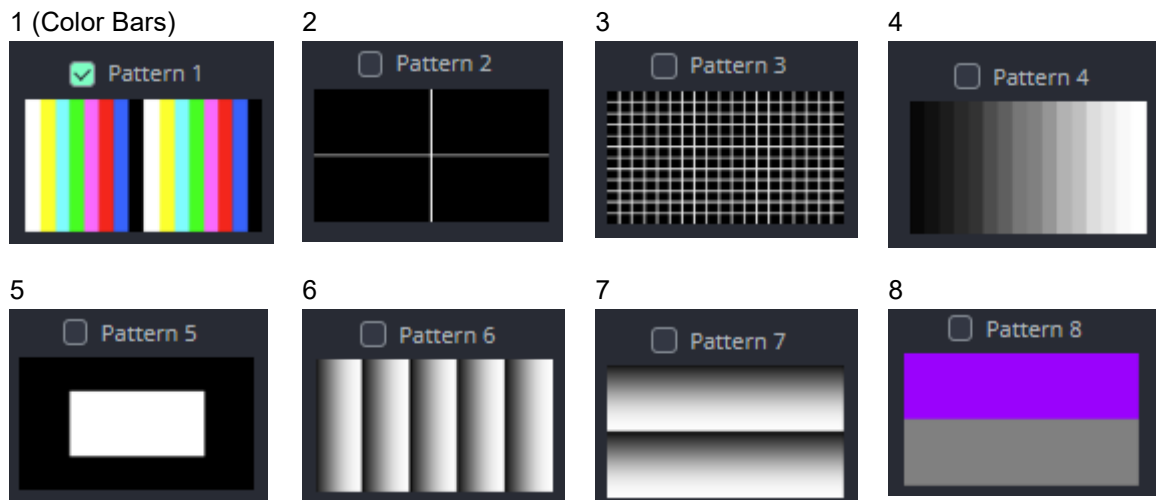

Figure 6: MTX3-88-HSA Embedded Patterns

### To route a pattern:

- Press **VIDEO** button. The VIDEO LED button illuminates.
- Press **OUT** button. The OUT LED button illuminates.



On the front panel buttons:

- An illuminated output button means that a display is connected on that output.
- An illuminated input button indicates the current pattern selected.

- Press the **PATTERN** button. The PATTERN button illuminates, and the output immediately switches to the selected type pattern.



Press **ALL** (instead of an output button) to route a pattern to all the outputs.

## Operating in ARC Mode

ARC (Audio Return Channel) can be set from the front panel whether the output is ARC enabled/disabled.

ARC can also be set via the embedded webpages (only enabled output/input port ARC can be routed).

The HDMI output ARC can be routed only to any of the HDMI ports.

1. Press **ARC** button. The ARC button LED illuminates.
2. Press **IN #** button. The IN# button LED illuminates.  
The OUT # or OFF button LED illuminated shows the current switch.
3. Press the **OUT#** button, or the **OFF** button to switch the output in ARC Audio to the selected IN# ARC Audio.

## Routing HDMI Audio Output Signals to HDMI Input Ports

To route an HDMI audio output to HDMI input ports, enable ARC on the HDMI output ports and then route them.

To set an HDMI output to ARC mode:



ARC can be enabled or disabled at any time, regardless of whether a display is connected to the HDMI output or not.

1. Press the **ARC** button.  
The ARC button LED is illuminated. Other function indicators LED are OFF.
2. Press **IN #** button.  
The IN# button LED illuminates. The OUT# of OFF button LED illuminates showing the current switch status.
3. Press **OUT#** button or the **OFF** button.  
The Output in ARC Audio is switched to the selected IN# ARC audio.

## Storing and Recalling a Setup

**MTX3-88-HSA** can store up to 8 setups. Each setup includes the video and audio current switching state.

In Store-Recall mode, OUT 1 corresponds to setup 1, OUT 8 corresponds to setup 8.

To store a setup:

1. Press **STO**.  
The **STO** button illuminates.
2. Press an **OUT** button (from 1 to 8).  
For example, when pressing OUT 5, the current device state is stored to setup 5.

3. Press **LOCK**.

The corresponding **OUT#** and **STORE** button flashes for 3~5 seconds indicating that the device state is stored to setup 5.

A setup is stored.

**To recall a setup:**

1. Press **RCL**.

The **RCL** button illuminates and **OUT 1** to **OUT 8** flashes.

2. Press the corresponding **OUT** button (from 1 to 8).

3. Press **LOCK**.

The recalled setup is applied and the **RCL** button no longer illuminates.



If the **LOCK** button is not pressed in approximately 15 seconds, the unit will automatically exit the operation mode and return to the **VIDEO** switching interface.

A setup is recalled.

---

## Switching Modes

Use the front panel buttons for the following switching modes:

- Press **VIDEO** to switch the video signal of a selected input to the selected output.
- Press **D-AUDIO** (HDMI embedded audio signal) to switch the digital audio signal of a selected input to the selected output.
- Press **A-AUDIO** (analog signal on 5-pin terminal block) to switch the analog audio signal of a selected input to the selected output.
- Press **VIDEO + D-AUDIO** simultaneously to switch the video and digital audio signals of a selected input to the selected output.
- Press **VIDEO + A-AUDIO** simultaneously to switch the video and analog audio signals of a selected input to the selected output.
- Press **PATTERN** to switch a pattern signal (selected by the input buttons) to the selected output.
- Press **ARC** and then an input button to set that input source to ARC.

---

## Copying EDID

You can copy the EDID to an input from a connected output or use the default EDID.

### To set the input port EDID via the front panel buttons

To set the input port using the output monitor EDID:

1. Press **EDID**. The EDID button LED lights, indicating the EDID operation state: all input indicators off and all output indicators off.
2. Press the corresponding IN button and the button LED flashes: multiple IN buttons can be selected simultaneously.
3. Press an output button the button LED lights.
4. Press **Lock**. The LOCK button LED lights and the EDID LED flashes for about 3-5 seconds to copy output monitor EDID to the selected input port.
5. The setting was successful and the unit returns to the VIDEO switch interface.

To set input port using default EDID:

1. Press **EDID**. The EDID button LED lights, indicating the EDID operation state: all input indicators off and all output indicators off.
5. Press the corresponding IN button and the button LED flashes: multiple IN buttons can be selected simultaneously.
6. Press **LOCK** button. The LOCK button LED lights and the EDID LED flashes for about 3-5 seconds to copy the default EDID to the selected input port.
7. The setting was successful and the unit returns to the VIDEO switch interface.

---

## Operating via Ethernet

You can connect to **MTX3-88-HSA** via Ethernet using either of the following methods:

- Directly to the PC using a crossover cable (see [Connecting Ethernet Port Directly to a PC](#) on page [19](#)).
- Via a network switch or router, using a straight-through cable (see [Connecting Ethernet Port via a Network Switch](#) on page [21](#)).



If you want to connect via a router and your IT system is based on IPv6, speak to your IT department for specific installation instructions.

### Connecting Ethernet Port Directly to a PC

You can connect the Ethernet port of **MTX3-88-HSA** directly to the Ethernet port on your PC using a crossover cable with RJ-45 connectors.



This type of connection is recommended for identifying **MTX3-88-HSA** with the factory configured default IP address.

After connecting **MTX3-88-HSA** to the Ethernet port, configure your PC as follows:

1. Click **Start > Control Panel > Network and Sharing Center**.
2. Click **Change Adapter Settings**.

- Highlight the network adapter you want to use to connect to the device and click **Change settings of this connection**.

The Local Area Connection Properties window for the selected network adapter appears as shown in [Figure 7](#).

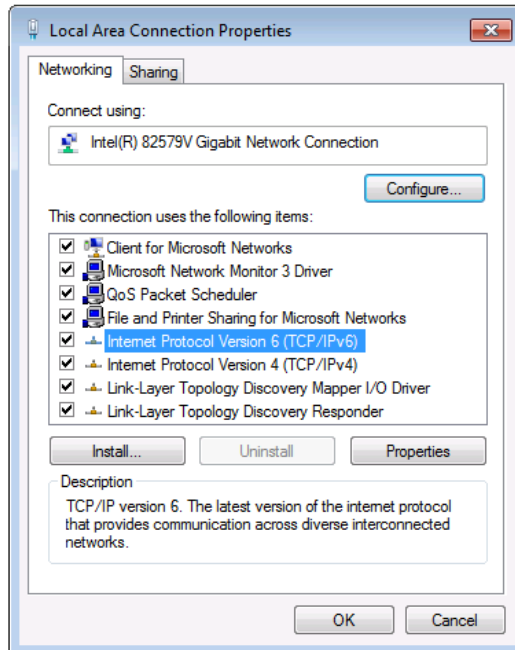

Figure 7: Local Area Connection Properties Window

- Highlight either **Internet Protocol Version 6 (TCP/IPv6)** or **Internet Protocol Version 4 (TCP/IPv4)** depending on the requirements of your IT system.
- Click **Properties**.

The Internet Protocol Properties window relevant to your IT system appears as shown in [Figure 8](#) or [Figure 9](#).

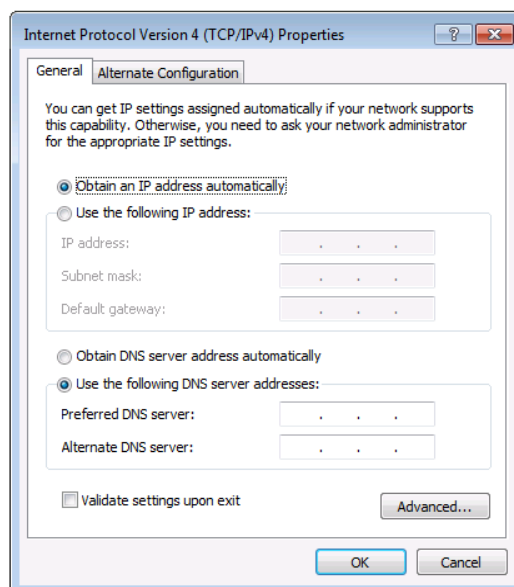

Figure 8: Internet Protocol Version 4 Properties Window

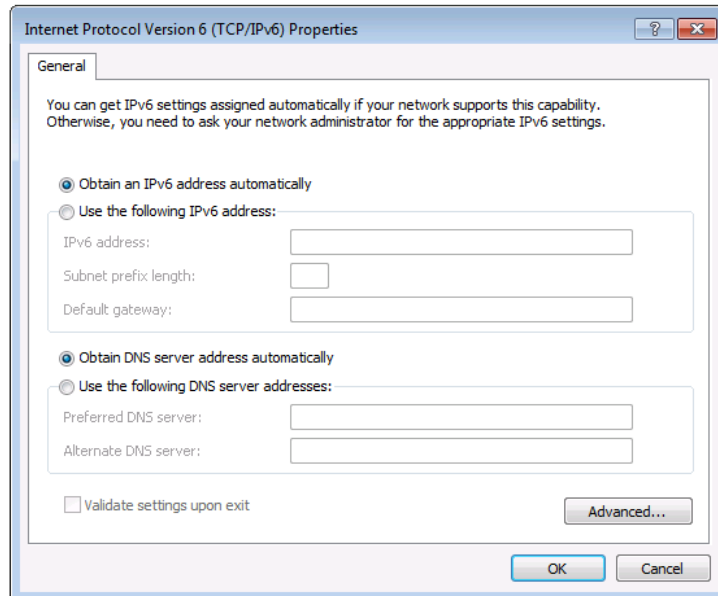

Figure 9: Internet Protocol Version 6 Properties Window

6. Select **Use the following IP Address** for static IP addressing and fill in the details as shown in [Figure 10](#).

For TCP/IPv4 you can use any IP address in the range 192.168.1.1 to 192.168.1.255 (excluding default 192.168.1.39 fallback address) that is provided by your IT department.

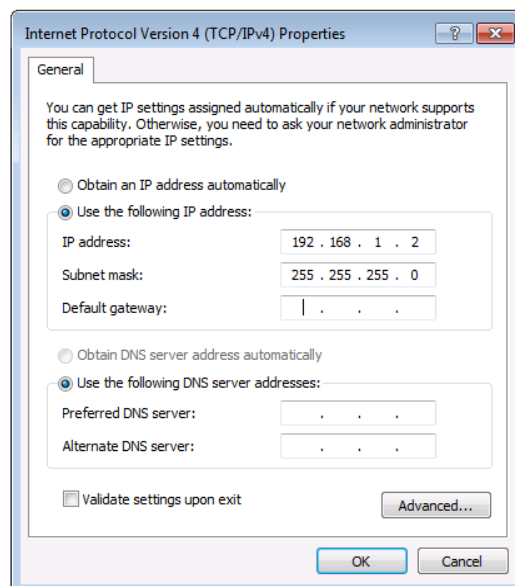

Figure 10: Internet Protocol Properties Window

7. Click **OK**.
8. Click **Close**.

## Connecting Ethernet Port via a Network Switch

You can connect the Ethernet port of **MTX3-88-HSA** to the Ethernet port on a network switch or router using a straight-through cable with RJ-45 connectors.

## Configuring Ethernet Port

You can set the Ethernet parameters via the embedded Web pages.

## Discovering and acquiring IP address

**MTX3-88-HSA** includes IP address auto-acquiring policy via LAN-connected DHCP server by default. When no DHCP server is detected, a fallback static IP address of 192.168.1.39, and 255.255.255.0 subnet mask (class C), is assigned until an IP address is acquired via the DHCP server.

For more information, refer to Product Page Technical Note in <http://www.kramerav.com/product/MTX3-88-HSA>.

# Using Embedded Web Pages

**MTX3-88-HSA** enables you to configure settings via Ethernet using built-in, user-friendly web pages. The Web pages are accessed using a Web browser and an Ethernet connection.

 You can also configure **MTX3-88-HSA** via Protocol 3000 commands (see [Protocol 3000 Commands](#) on page 60).

Before attempting to connect:

- Perform the procedure in (see [Operating via Ethernet](#) on page 19).
- Ensure that your browser is supported.

The following operating systems and Web browsers are supported:

Operating Systems	Browser
Windows 10 and higher	Edge
	Chrome
Mac	Safari
iOS	Safari
Android	N/A

 If a web page does not update correctly, clear your Web browser's cache.

 Check that Security/firewalls are not blocking HTTP traffic between the device and the user PC.

**To browse the MTX3-88-HSA web pages:**

1. Enter the IP address of the device in the address bar of your internet browser (default = 192.168.1.39).

If security is enabled, the Login window appears.

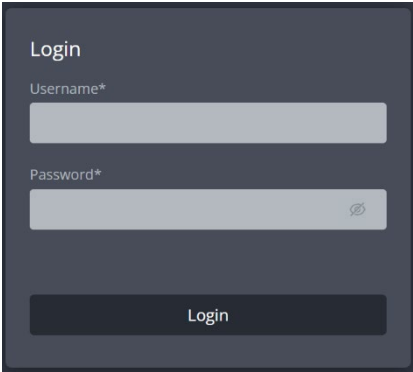

Figure 11: Embedded Web Pages Login Window

2. Enter the Username (default = Admin) and Password (default = Admin) and click **Sign in**. The default web page appears.

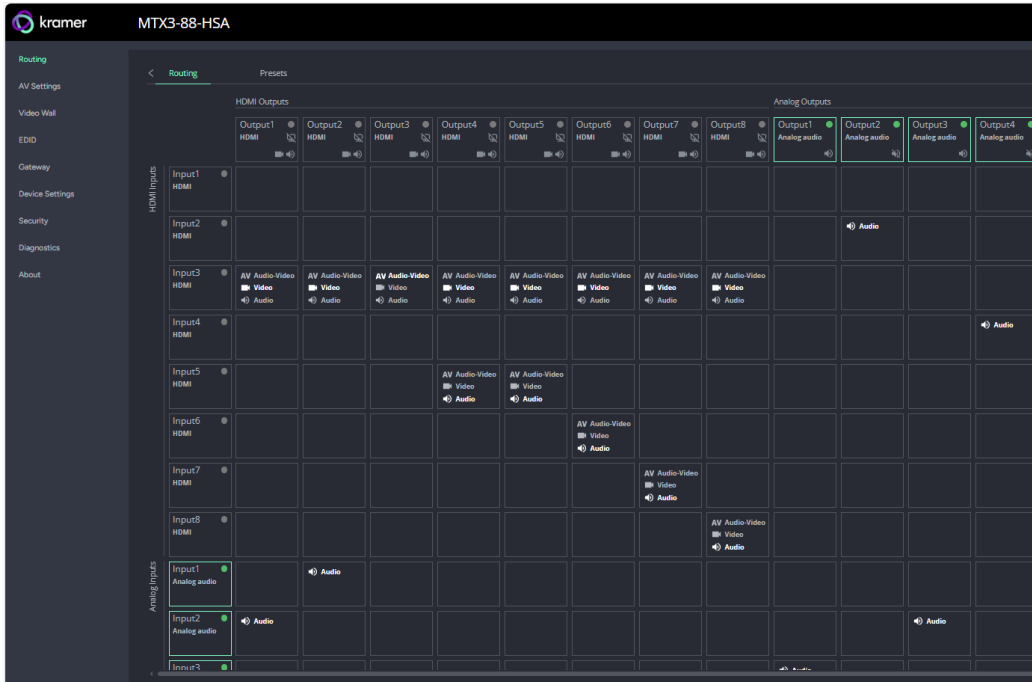

Figure 12: Switching Page with Navigation List on Left

3. Click the desired Web page or click the arrow to hide the navigation list. You can browse webpages.

## Routing

### Navigating to the Routing Tabs

1. In the Navigation pane, click **Routing**. The Routing page appears.
2. Select the **Routing** tab.

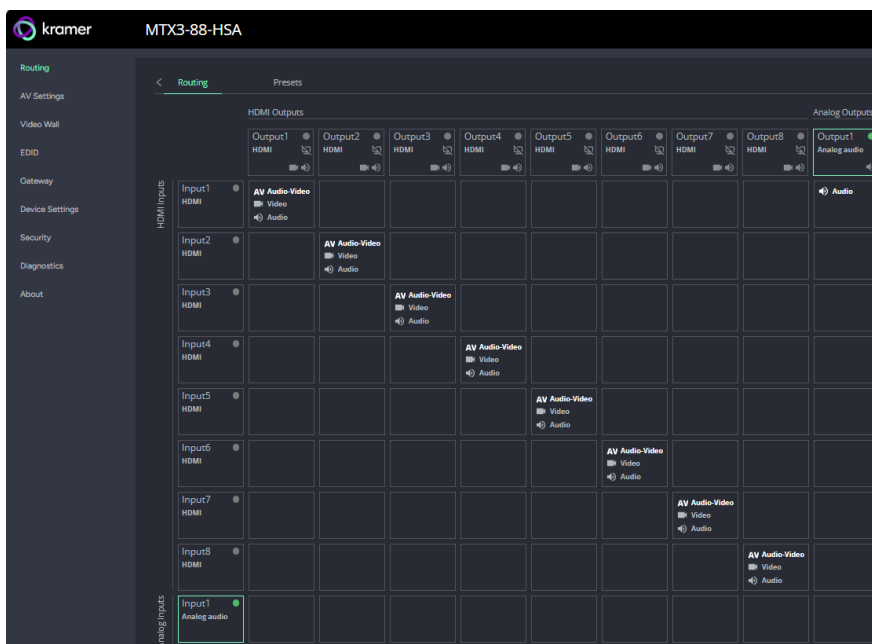

Figure 13: AV Routing Landing Page

# AV Routing

This section allows users to route inputs to outputs.

## AV Routing Operation

Routing is available for Video only, Audio only, or both Audio & Video.

1. In the Navigation pane, click Routing>Routing tab.
2. Click one or multiple cross-points between inputs and outputs to switch the selected inputs to the selected outputs:
  - HDMI Input/Output 1-8
  - ANALOG Input/Output 1-4
  - ARC Input/output 1-8 (dependent on AV configuration>ARC enablement. Refer to [Video Settings](#) onPage 30).



- To select a cross-point, make sure to click the text within the square:
  - Select AV Audio-Video for both Audio & Video.
  - Select Video for switching video only
  - Select Audio for switching Audio only.

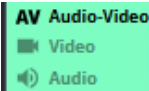

Figure 14: Click Text to Select Cross-Point

- A green light on a button indicates a connected source/acceptor.

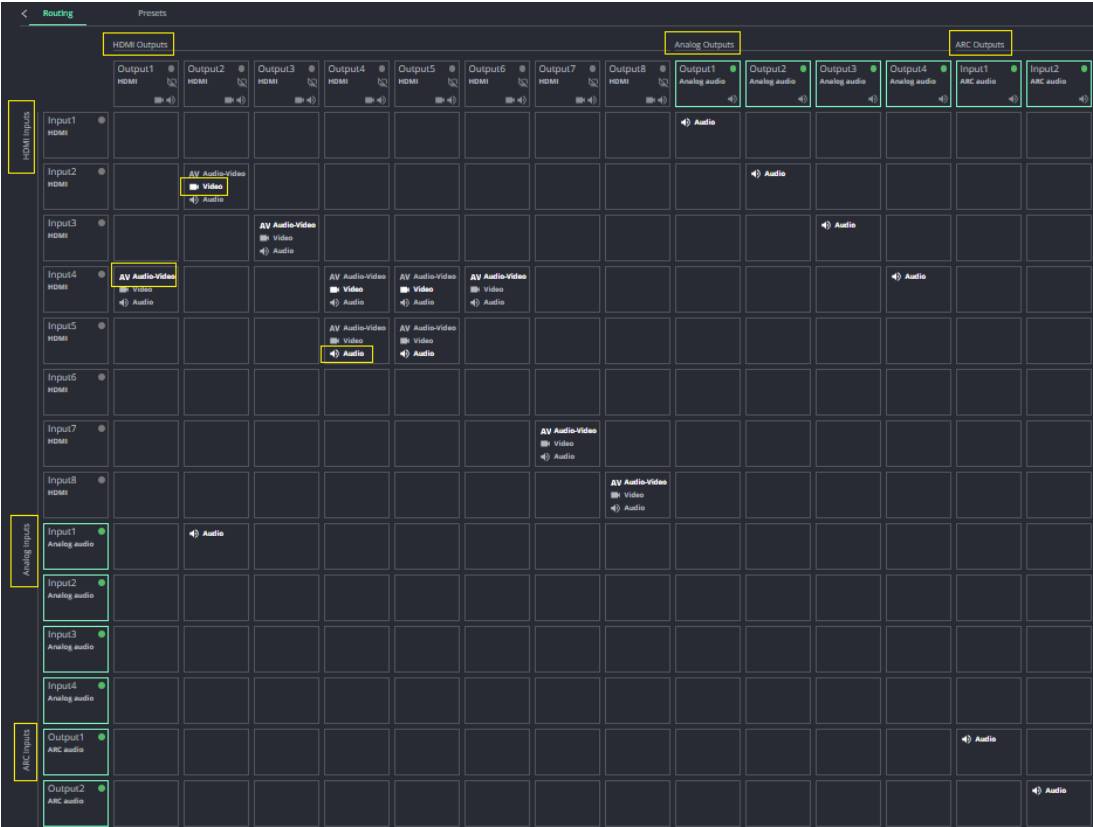







Figure 15: Matrix Grid View

3. If required, perform one of the following:
  - Click  (on output port) to mute the video output signal.  indication appears.
  - Click  (on output port) to mute the audio output signal.  indication appears.
  - Click  (on output port) to turn Pattern set on.  indication appears.

The selected inputs are switched to the selected outputs.

## Adjusting Input and Output Port Settings

1. In the navigation list select AV Settings>Video tab.
  - To adjust input port settings (see [Configuring Video Input Settings](#) on Page 30).
  - To adjust output port settings (see [Configuring Video Output Settings](#) on page 31).

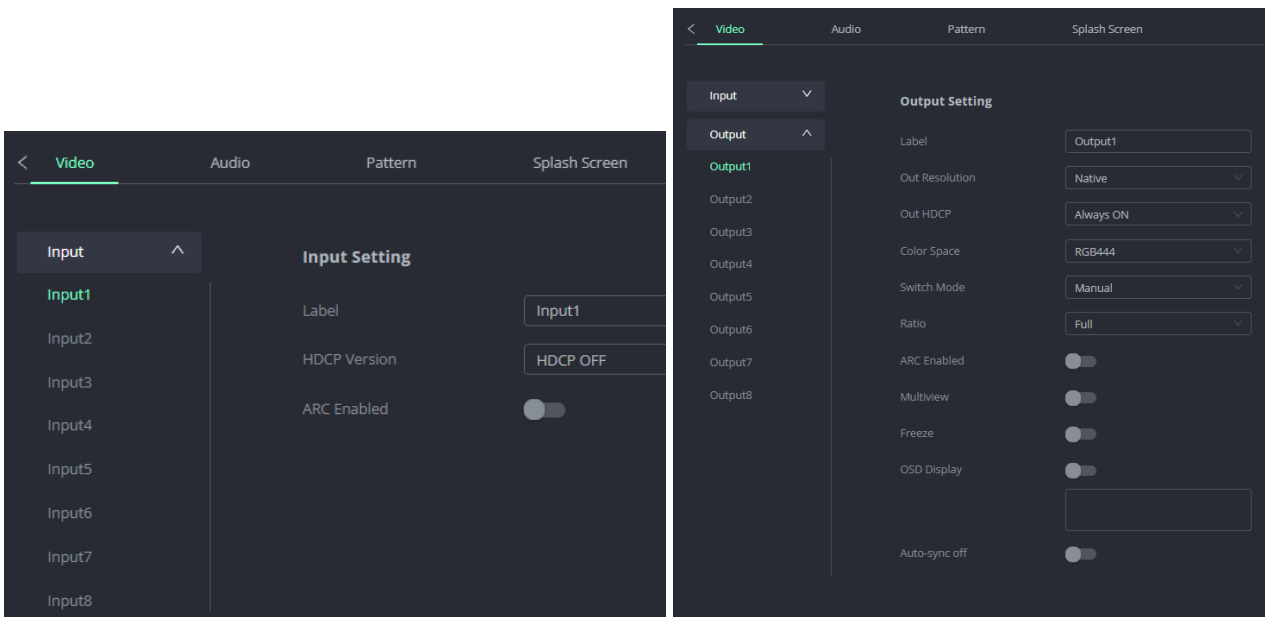

Figure 16: Input/Output Port Settings Page

## Saving a Preset

To save a specific matrix routing scheme and configuration:

1. On the bottom of the AV grid, click **Save as Preset**.

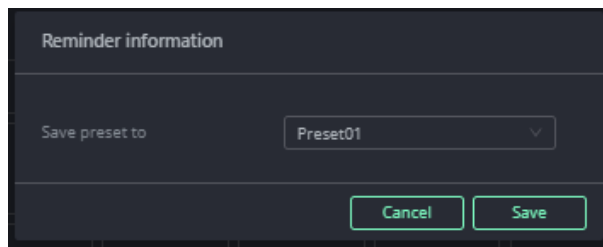

Figure 17: Save Selected Routing & Configuration as a Preset

2. Enter the following data:
  - Select a preset number to save (8 in total).
3. Click:
  - **Save Preset** to save the selected routing and configuration to the selected preset

number.

- **Cancel** to cancel the operation.



If the current selected preset has already saved routing/configuration content, user can still select to save the new routing/configuration content to this preset, but the previous content in this preset will be overwritten.

To check, view, delete and modify any existing preset, go to the Presets page. Refer to [Presets](#) on Page 27.

## Presets

This section allows users to add, display, activate, modify, delete, and recall saved presets.

### Adding a Routing Preset

1. In the Navigation pane, select Routing>Presets tab.



In the figure below, three presets were previously saved in the Routing tab, as examples.

If no presets were saved from the Routing tab, the list is blank.

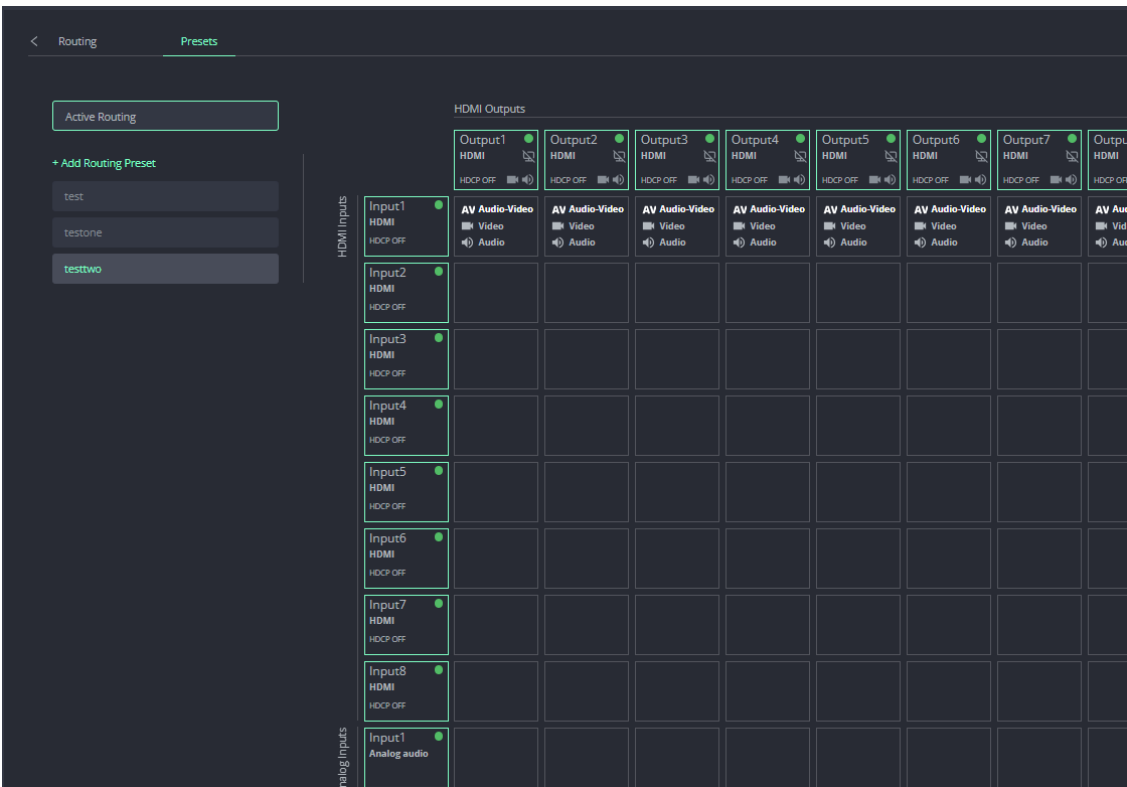

Figure 18: Presets Landing Page

2. Click one or multiple cross-points between inputs and outputs to switch the selected inputs to the selected outputs and then click **+Add Routing Preset**.

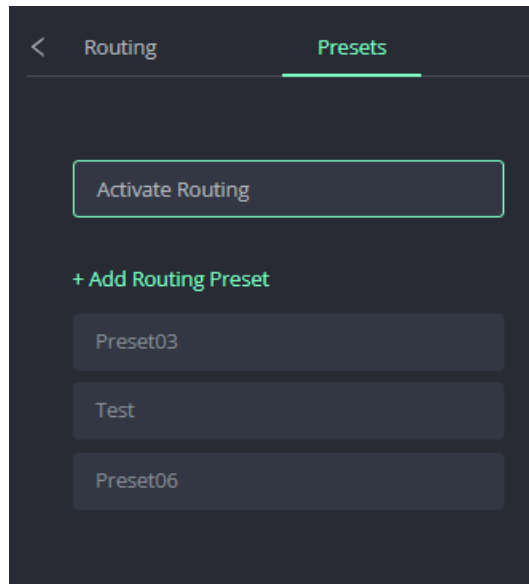

Figure 19: Select +Add Routing Preset

3. In the Reminder information dialog box, select from the Save preset to drop-down box (Preset 01-08) and click **Save**.

The preset is saved and appears in the left hand pane.

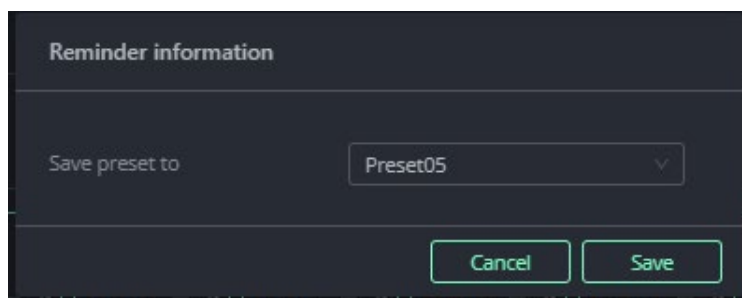

Figure 20: Save a New Routing Preset

## Saving a Preset

The user can save up to 8 presets for AV. For further details, refer to [Saving a Preset](#) in Page [26](#).

## Displaying a Preset

To display a saved preset:

1. In the left-hand pane, select the desired saved preset.
2. In the right-hand pane, the saved preset is displayed.

## Managing the Saved Presets

To activate a saved preset:

1. In the left-hand pane, select the desired saved preset. The saved presets are displayed on the matrix grid.

2. Click **Activate Routing**.

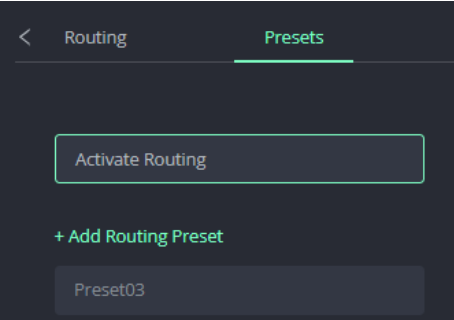

Figure 21: Activate a Saved Preset

4. The saved Preset is activated, and a message appears Application successful.

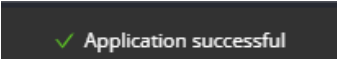

Figure 22: Saved Preset Activated.

4. Select Routing tab to view the saved preset.

**Deleting a Saved Preset**

**To Delete a saved preset:**

- 1. Select the desired saved preset row. It is displayed in green.
- 2. Click  to delete the saved preset.



Figure 23: Deleting a Saved Preset

The Saved Preset is now deleted.

**Modifying a Saved Preset**

**To Modify a saved preset:**

- 1. Select the desired saved preset row. It is displayed in green.



Figure 24: Modifying a Saved Preset

- 2. Click  to enable modification of the text field.
- 3. Delete the current name, enter the new name of the saved present and click **Save**.



Figure 25: Entering a New Name

The Saved Preset name is now modified.

## AV Settings

This section allows users to set parameters for video and audio inputs / outputs.

Users can also set parameters for the Pattern and Splash Screen outputs.

### Navigating to the AV Settings Tab



- The AV Settings tabs include Video, Audio, Pattern and Splash Screen.
- The example below shows how to navigate to the Video Settings tab.

1. In the navigation pane, select **AV Settings**.
2. In the top menu bar, select **Video**.

The Video Settings page is now available.

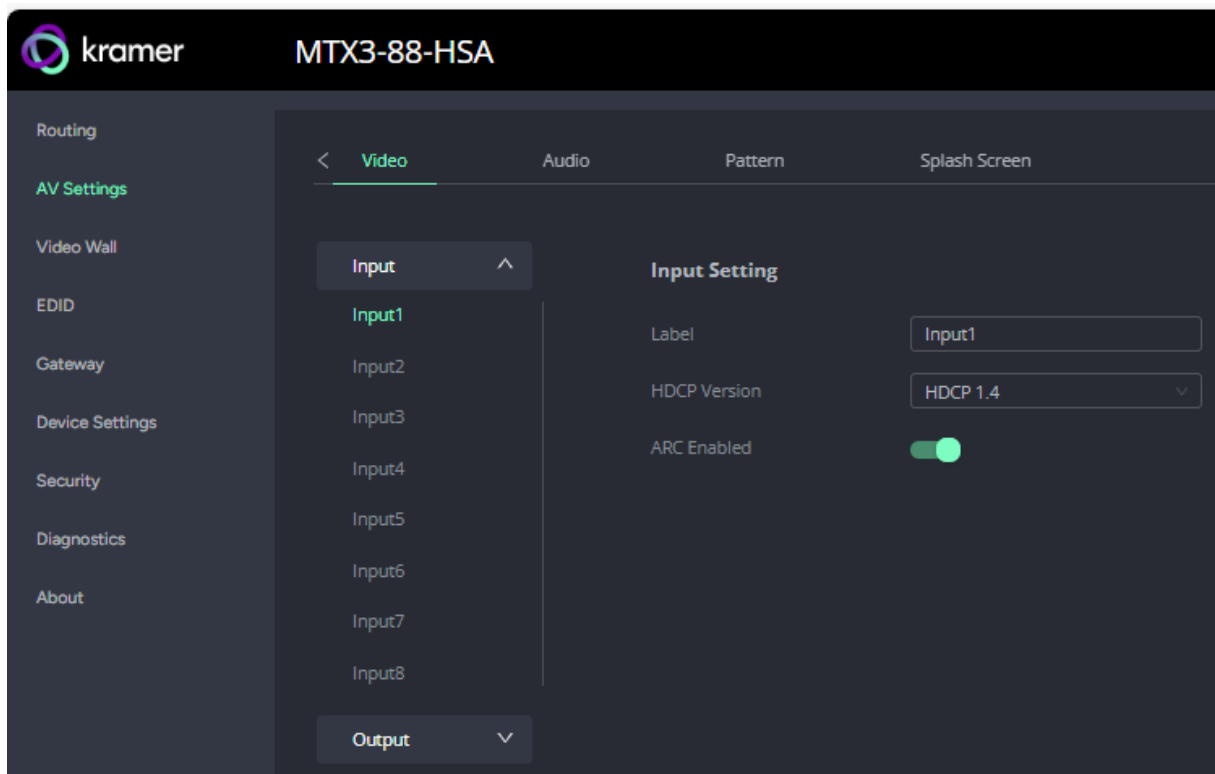

Figure 26: AV Settings Video Landing Page

## Video Settings

### Configuring Video Input Settings

To configure Video input settings:

1. Navigate to the AV Settings>Video tab (see [Navigating to the AV Settings Tab](#) on Page 30).
3. In the left-hand pane, select the relevant **Input** (Input1-8).

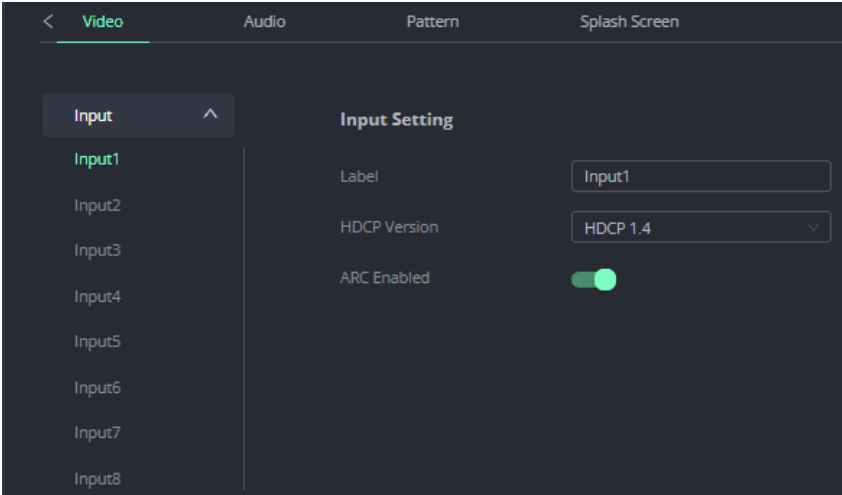

Figure 27: Input Settings

- 4. For each input set the following parameters:
  - **Label:** Enter an input name.
  - **HDCP Version:** Select the HDCP status of the signal: NO HDCP, HDCP 1.4, or HDCP 2.2.
  - **ARC Enabled:** Select to enable/disable.

When ARC function is enabled, the matrix displays the relevant ARC ports on the Routing page, which can be switched over.

- 5. Click **Save**.

Video inputs are set.

### Configuring Video Output Settings

To configure the Video Output settings:

- 1. In the left-hand pane, select the relevant **Output** (Output1-8).

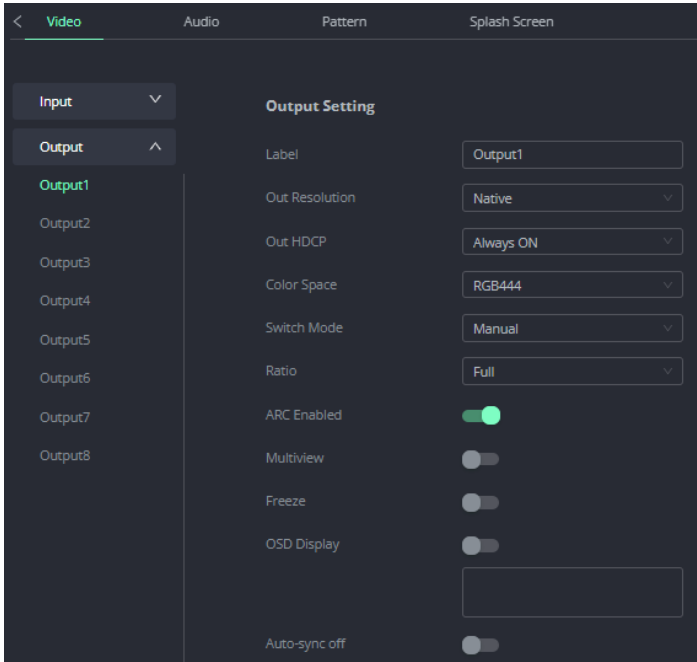



Figure 28: Output Settings

2. For each output set the following parameters:

- **Label:** Enter an output name
  - **OUT Resolution:** Select Out resolution
  - **OUT HDCP:** Set HDCP to Follow Input or Follow Output
  - **Color Space:** Set the color space: RGB444 or YUV444
  - **Switch Mode:** Select the auto switching policy:
    - **Manual Mode:** Channel can be switched manually.
    - **Priority Mode:** Switching mode is performed according to a channel with a pre-determined higher priority.
    - **Last Connected Mode:** Switching is performed according to the order of the last insertion.
  - **Ratio:** Select Full or Best Fit ratio
  - **ARC Enabled:**
    - Enabling ARC changes the state of the matrix audio channel.
    - Set the input and output port ARC parameter value to ON, and the audio data stream can bypass the matrix transmission.
      - For example: The input port is connected to the power amplifier output port, and the output port is connected to the SONY TV.
        - On the webpage, the ARC of the input port serves as the output channel, switching all the effective audio output through the audio matrix, and the sound can be heard through the power amplifier.
        - SONY TV Plays its own audio, through the audio data flow, amplifier output SONY TV played audio, amplifier LCD screen display the word "TV".
  - **Multiview:** can be activated only on outputs: 1,3,5 and 7.
    - Under AV setting: you can activate the Multiview per output.
    - A small screen will appear in the lower right corner of the output screen.
- 
  - If you select for example output1 as a Multiview, output2 will be disabled (no video).
  - If you activate the Multiview on output 3, output4 will be disabled and so on
- **Freeze:** Select to enable output freezing function.
  - **OSD Display:** Set to enable output OSD function option.
    - When the OSD is started, the output port will embed the characters of the character set into the current output video stream, and the corresponding effect can be seen on the TV.
      - Enter the characters in the text field to display on the TV. Maximum character length is 16.

- **Auto-sync off:** Select to enable Auto-sync Off.
  - If disabled, the device will shut down the HDMI output +5v when there is no active signal to the output.
  - If enabled, the device will shut down the HDMI output +5v based on the value entered in the **Set the Auto-sync off time** (detailed below).
  - **Set the Auto-sync off time** value:” Enter a value anywhere from 5 – 900 seconds.



If on an output port the +5V is shut down, a monitor **connected** or **disconnected** from the output cannot be indicated correctly and immediately on the keyboard.

3. Click **Save** to save all settings.

- A screen appears asking if you want to apply the changes to all outputs.
  - Click **Save** to apply changes to all outputs.
  - Click **Cancel** to apply changes to the specific output.

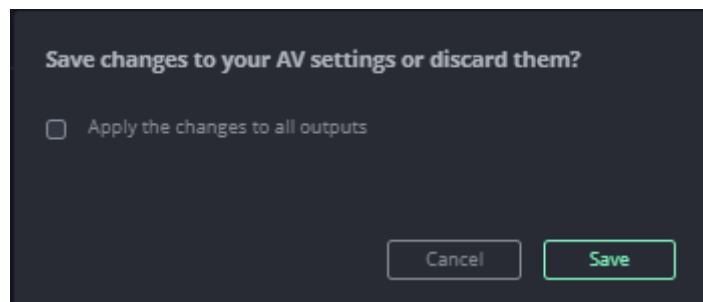

Figure 29: Save Changes to AV Settings

Audio output settings are configured.

## Audio Settings

### Configuring Audio Input Settings

To configure Audio input settings:

1. Navigate to the AV Settings>Audio tab (see [Navigating to the AV Settings Tab](#) on Page [30](#)).
6. In the left-hand pane, select the relevant **Input** (Input1-4).

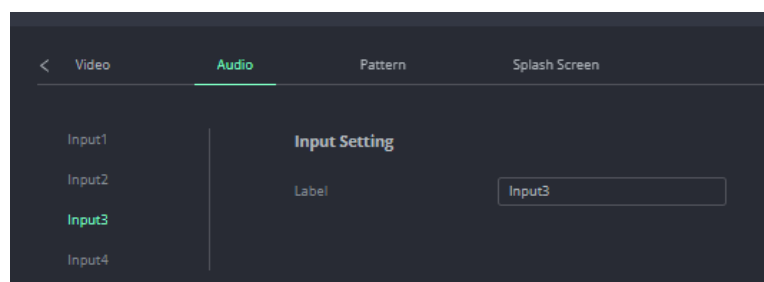

Figure 30: Audio Input Settings

7. For each input set the following parameters:

- **Label:** Enter an input name.
4. Click **Save**, to save the labels.
- Audio Input settings are configured.

## Configuring Audio Output Settings

To configure the Audio Output settings:

1. In the left-hand pane, select the relevant **Output** (Output1-4).

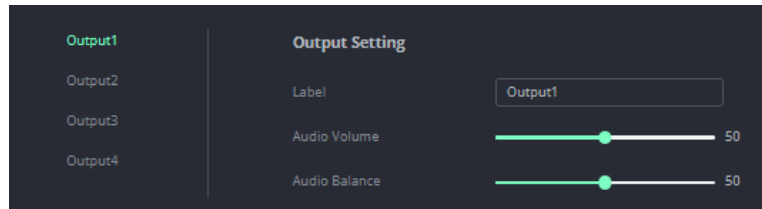

Figure 31: Audio Output Settings

8. For each output set the following parameters:
    - **Label:** Enter an input name.
    - **Audio Volume:** Use the slider to adjust the output volume. Default is 50.
    - **Audio Balance:** Use the slider to set the balance sounds of the analog audio output port. Default is 50.
  4. Click **Save**, to save the Configuration.
- Audio Output settings are configured.

## Pattern Settings

### Setting Output Pattern Settings

To Set Output Pattern settings:

1. Navigate to the AV Settings>Pattern tab (see [Navigating to the AV Settings Tab](#) on Page [30](#)).
9. In the left-hand pane, select the relevant **Output** (Input1-8)

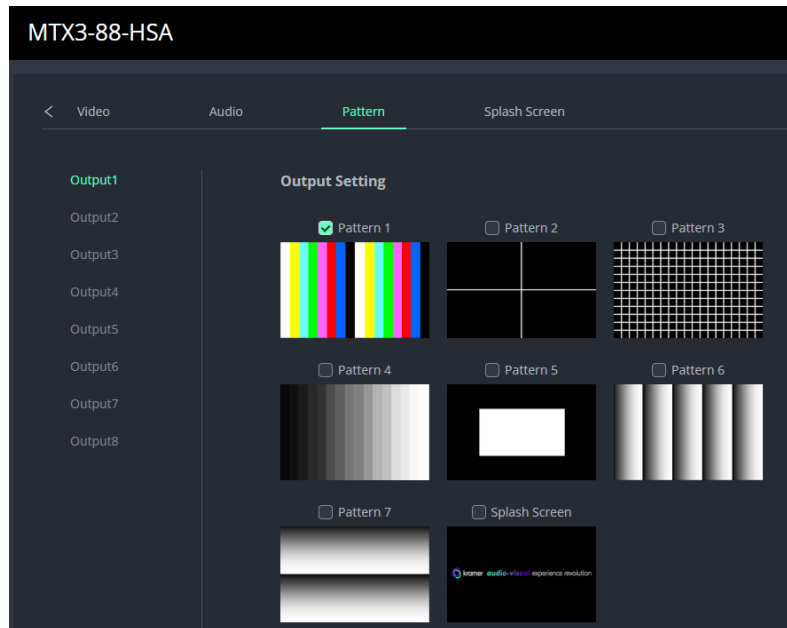

Figure 32: Audio Input Settings

3. For each output port (1-8), select from one of the available seven patterns, or the Splash screen.

4. Click **Save** to save the output pattern settings.

Output pattern settings are configured.

## Splash Screen

### Setting Splash Screen Settings

To Set Splash Screen settings:

1. Navigate to the AV Settings>Splash Screen tab (see [Navigating to the AV Settings Tab](#) on Page [30](#)).

10. In the left-hand pane, select the relevant **Output** (Input1-8).

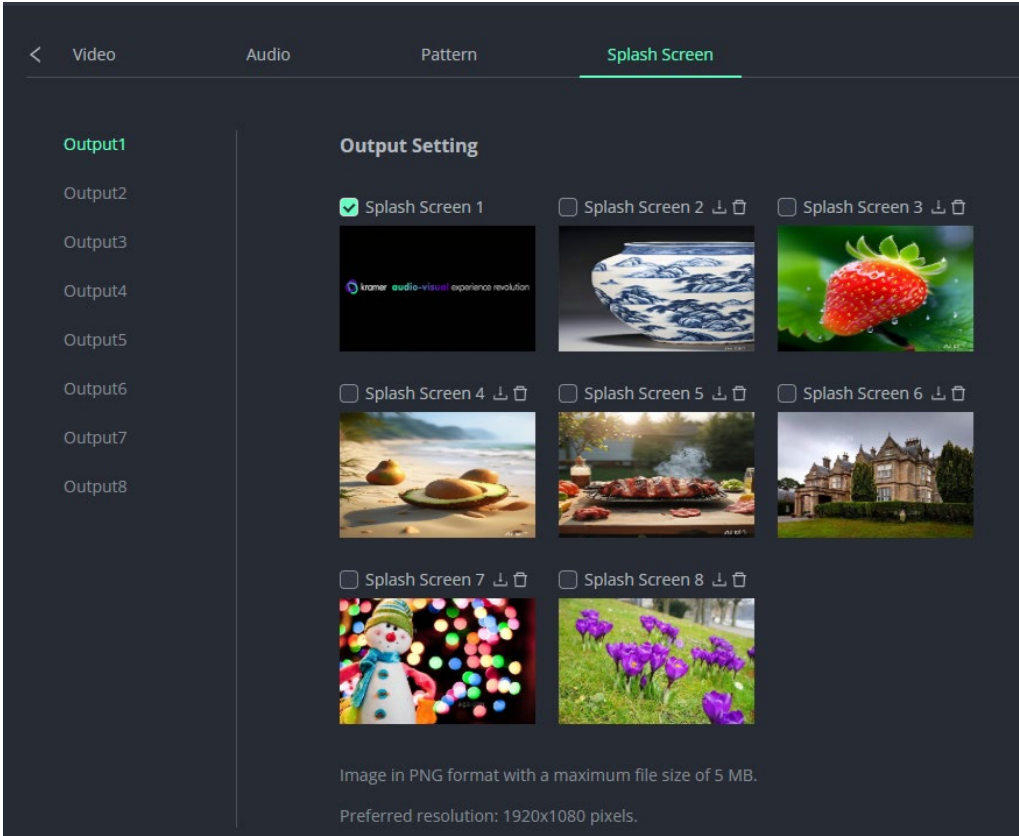

Figure 33: Splash Screen Settings

3. Select one of the following options and click **Save** to save settings:

- **Default:** For no input source, the output port displays the picture shown below as the screen saver.



This image cannot be edited by user.

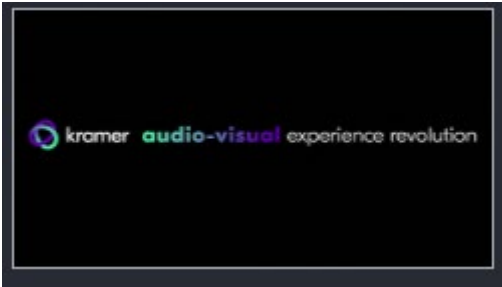



Figure 34: Default Splash Screen

- **Custom:** (Splash Screen 2-8) User can select, edit and/or delete the input source.
  - a. Next to the Splash Screen# field, click  .
  - b. Select the pictures from the connected PC library and click Open.
  - c. Select the quality of the image (High or Standard) and click **Save**.  
The image is uploaded and you can preview the image.

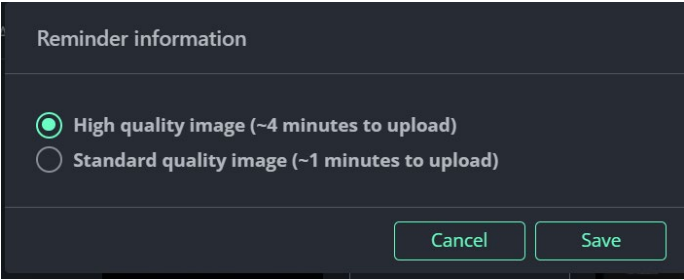

Figure 35: Select Image Quality



Image must be in .png format with a maximum file size of 5MB.  
Preferred resolution: 1900 X 1080 pixels.

d. Click **Save**, to save the custom splash screen saver.

Splash Screen savers are set for output ports.

# Video Wall

This section allows the user to set the output layout, resolution and bezel settings for the video wall.

## Configuring the Video Wall

To Configure the Video Wall:

1. In the Navigation pane, click Video Wall. The Video Wall page is now available.

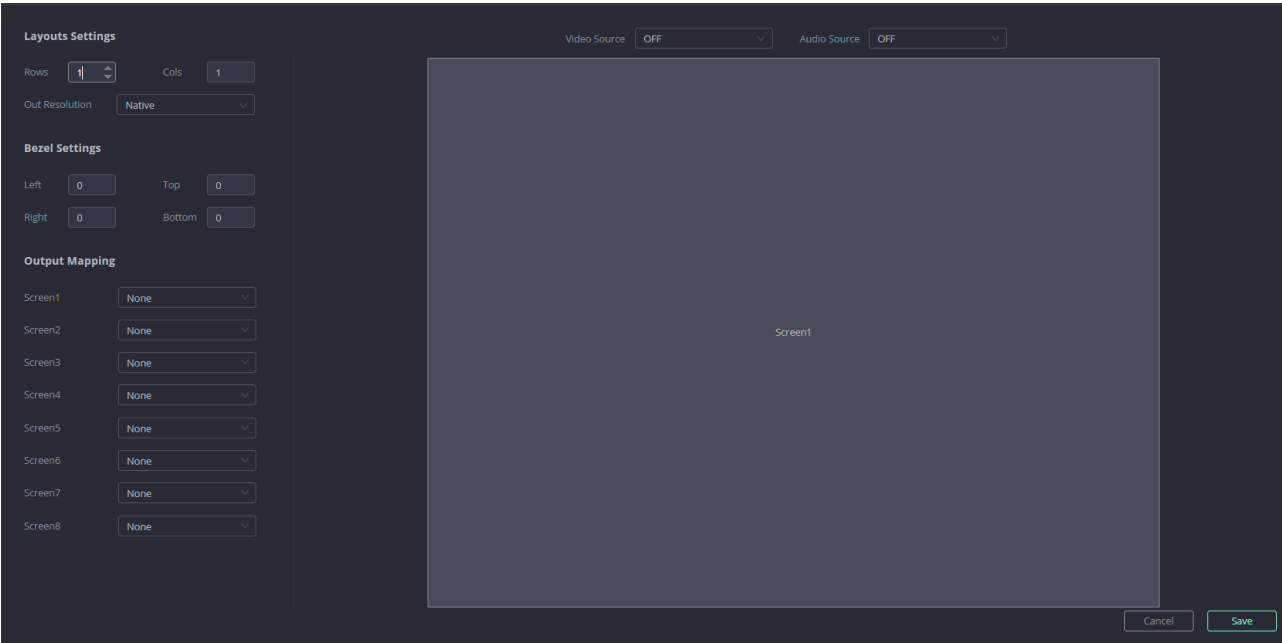

Figure 36: Video Wall Settings Page

2. In the **Layouts Settings**, set the output screen configuration::
  - Use the up/down arrows to select the number of rows/columns.
  - In the figure below, two rows and 4 columns are selected.

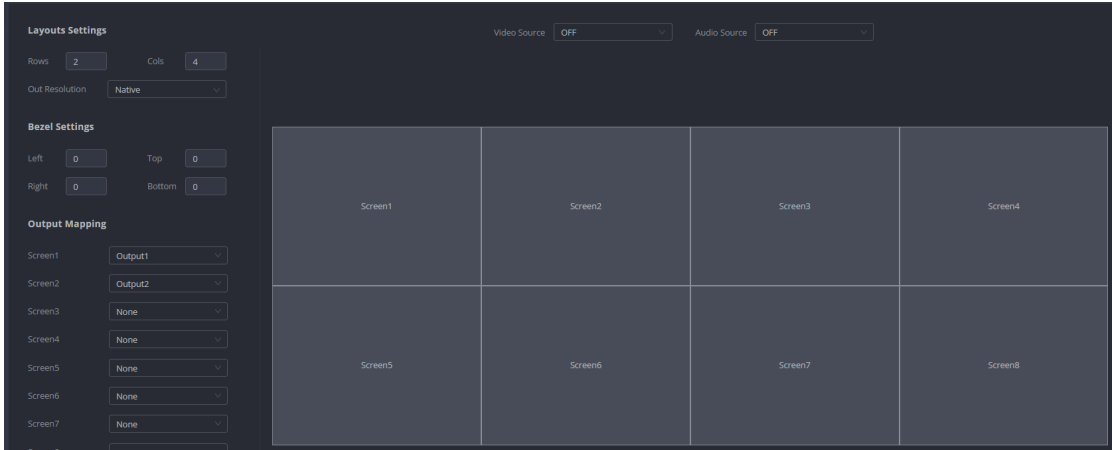
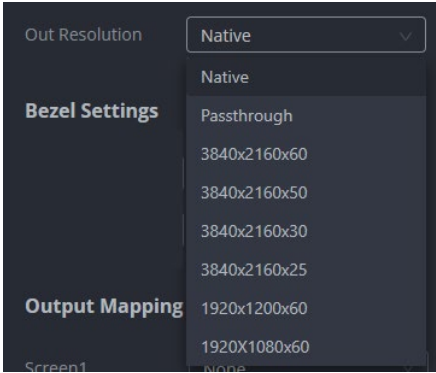

Figure 37: Setting Layout Settings

3. Select the **Out(put) Resolution:**



38: Setting Output Resolution Settings

4. Set Bezel compensation (mm) parameters for clean image

- **Top/Bottom/Left/Right:** Set bezel compensation for the distance between the inner frame and the outer frame in top/bottom/left/right position, to eliminate any image position deviations between video-wall displays.

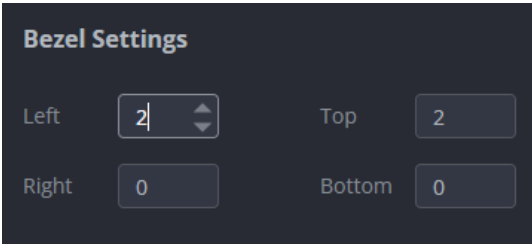

39: Setting Bezel Compensation

5. Set **Output Mapping:** Select the relevant output for each screen.

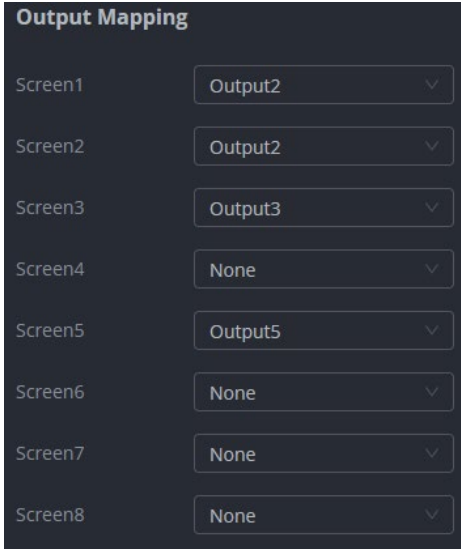

40: Setting the Position of the Output Screen

- 5. Select **Video Source**: Select the relevant Input for the video.
- 5. Select **Audio Source**: Select the relevant input for the audio.

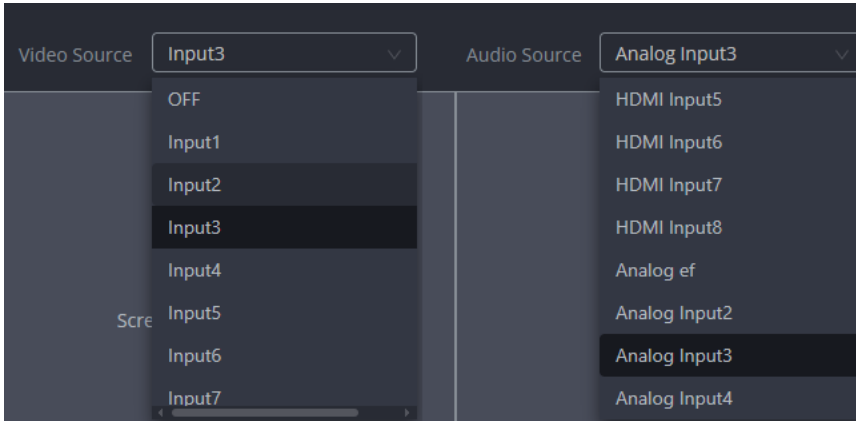

41: Setting the Input for Video and Audio

- 5. Set **Output Mapping**: Select the relevant output for each screen.
- 5. Click **Save** to set the Video Wall configurations.

# Managing EDID

MTX3-88-HSA enables you to copy an EDID from one of several different sources to the inputs.

To copy the EDID to the inputs:

- 1. Go to the EDID Management page.

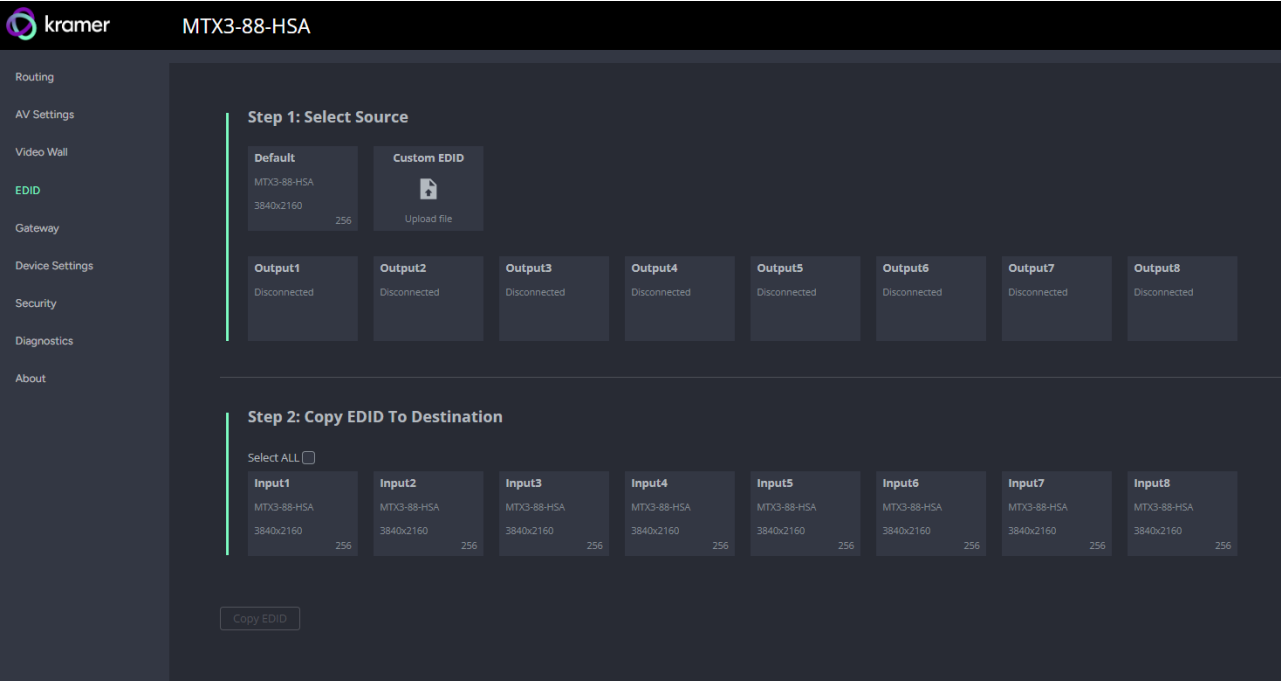

Figure 42: EDID Management Page

- 2. Under Step 1, select the EDID source (the output, any of the inputs, default or custom EDID).
- 3. Under Step 2, select one or more inputs as the destination for copying the EDID.
- 4. Click **COPY EDID**.

The EDID is copied to the destination.

# Setting CEC Gateway Properties

This section allows the users to select the CEC Gateway function for input / output ports.

If Gateway mode is selected, the user can control the connected devices using the commands control dialog box to the connected display(s).

If Extension (Passthrough) mode is selected, CEC commands pass from the connected source to the connected display.

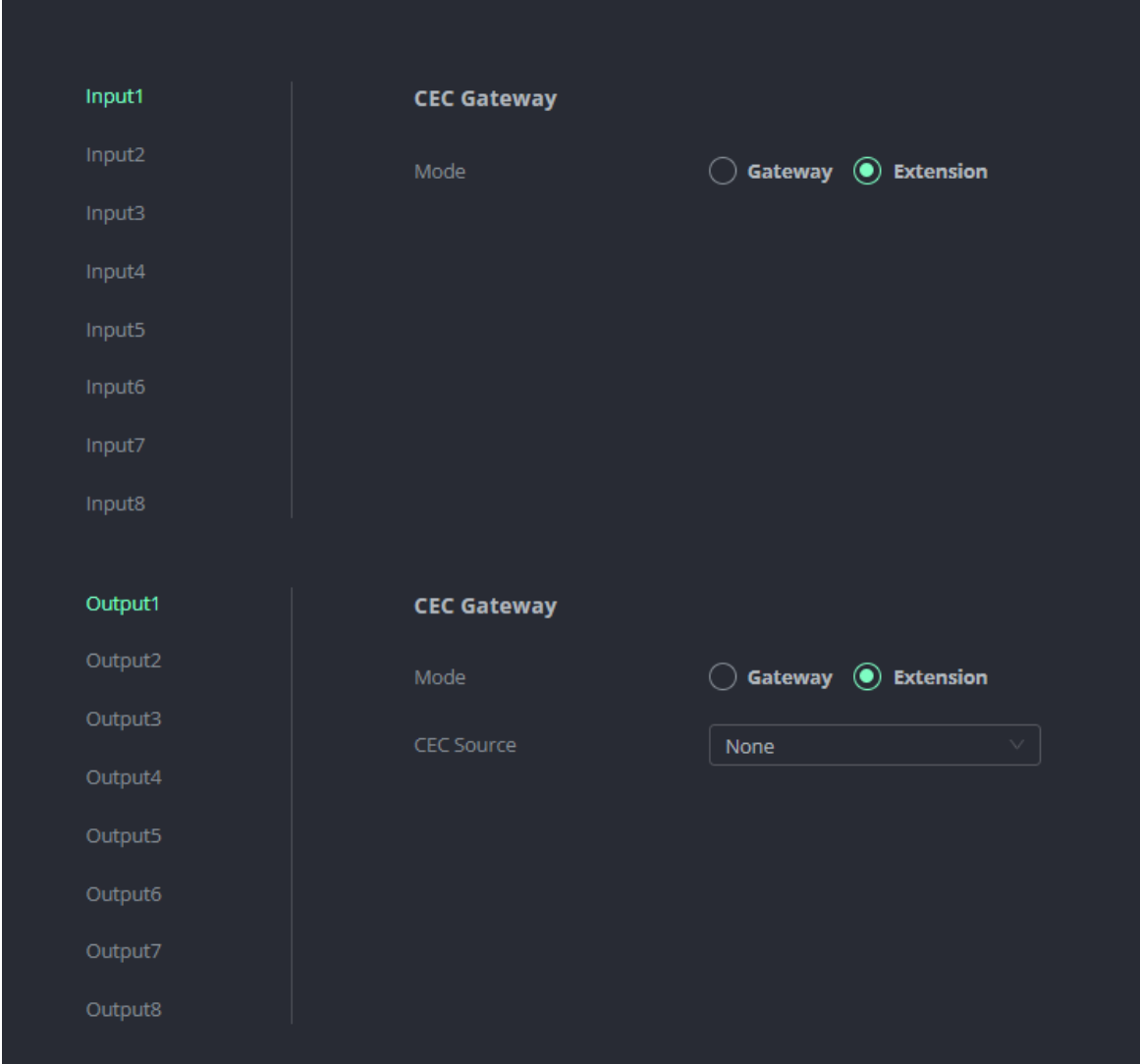
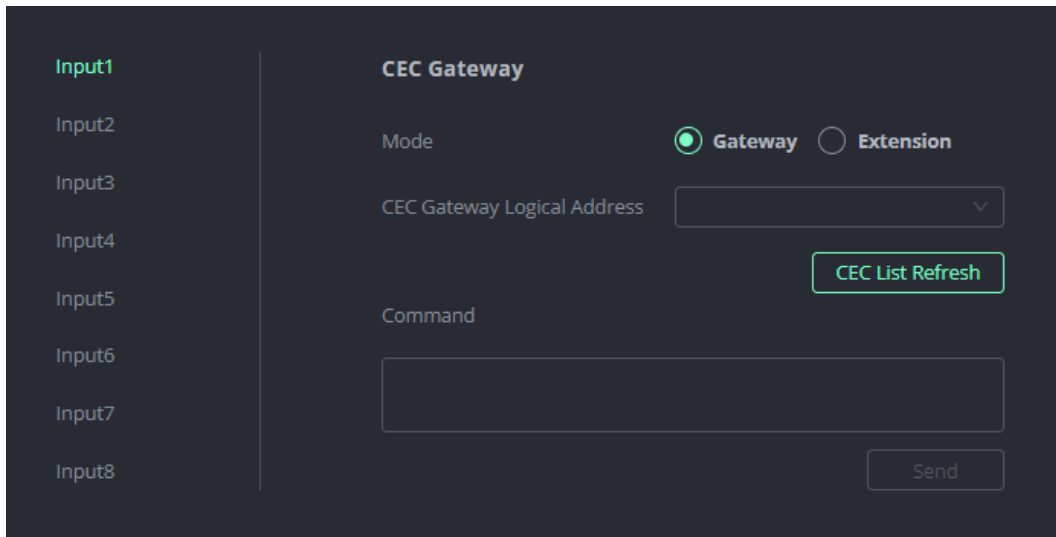

Figure 43: Gateway Management Page

## Selecting CEC Gateway Mode

To set up the CEC Gateway function:

1. Next to **Mode**, select the **GATEWAY** radio button (default).
2. **CEC Port**: Select an input/output port from the drop-down menu (HDMI Input 1-8, HDMI Output 1-8 to set).
3. Click **CEC List Refresh** to receive the list of CEC Gateway Logical Address.
4. **CEC Command**: Optionally (for diagnostics purposes) enter the CEC command of the controlled device. The CEC commands should be obtained from the controlled device's manual or supplier.
5. Click **Send** to send the command to control the port-connected CEC-enabled device.



The screenshot shows a web interface for configuring the CEC Gateway function. On the left, there is a vertical list of input ports labeled Input1 through Input8, with Input1 highlighted in green. The main area is titled 'CEC Gateway' and contains the following controls:

- Mode**: Two radio buttons, 'Gateway' (selected) and 'Extension'.
- CEC Gateway Logical Address**: A dropdown menu.
- CEC List Refresh**: A green button.
- Command**: A large text input field.
- Send**: A button.

Figure 44: Setting up Gateway Function

# Setting the CEC Extension Mode (Pass-through)

To set up the Extension mode:

1. Select working mode for input:
  - Select Extension (default mode).
2. Route the extension to an assigned input and output port mode.
  - Select the desired Output (1-8).
  - In the CEC Source drop-down list, select the Input source.

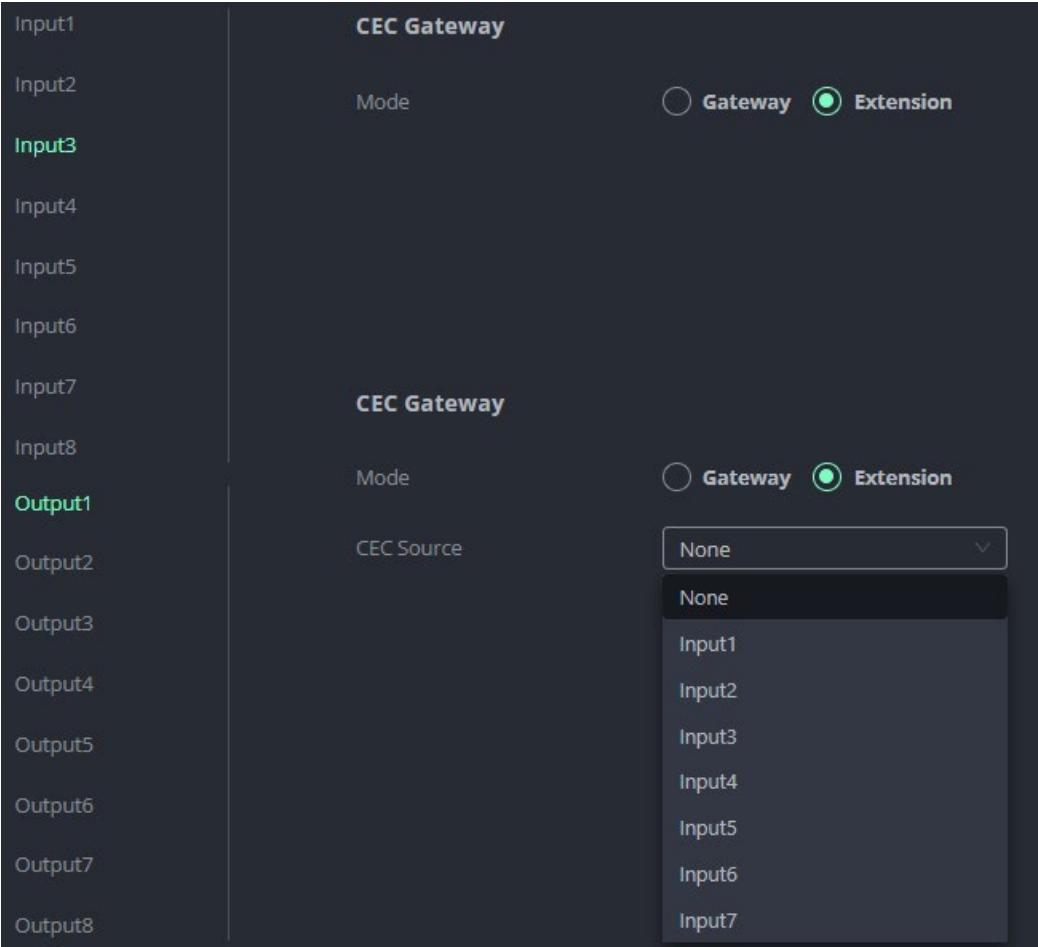

Figure 45: Select Extension Mode for Input/Output Ports

The CEC source of the output port now selects the input signal.

## Setting Device Properties

This section details the following actions:

- [Device Profile and Maintenance](#) on Page [44](#).
- [Setting Networking Properties](#) on Page [47](#)
- [Upgrading Firmware](#) on Page [47](#)
- [Setting Time and Date](#) on page [49](#).

## Device Profile and Maintenance

### Changing Device Name

MTX3-88-HSA enables you to change the DNS name of the device.

To change the device name:

1. Go to the **Device Settings > General** page.

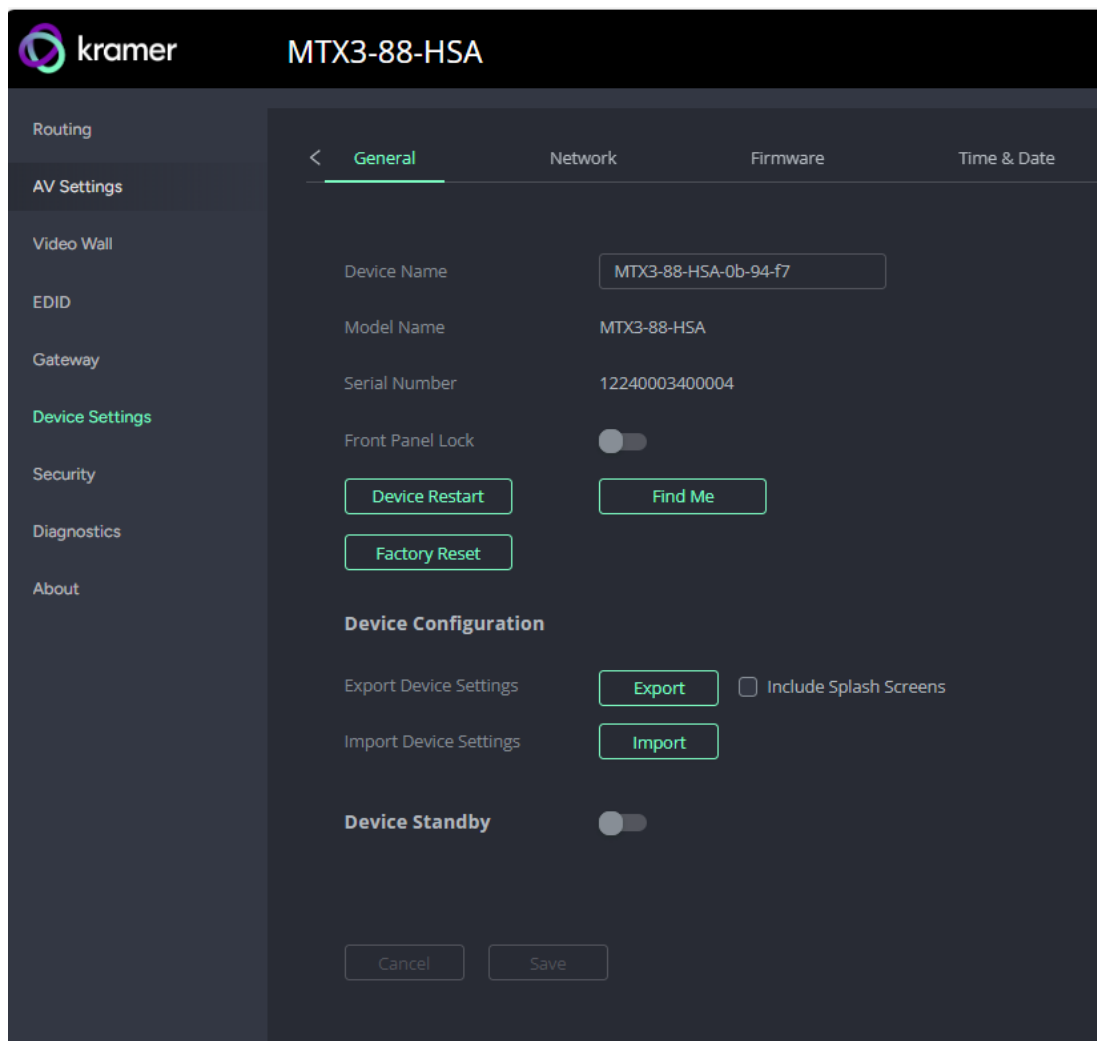

Figure 46: Device > General Page

2. Under General, change the device name and click **SAVE**.

The device name is changed.

## Locking/Unlocking the Front Panel

### To Lock/Unlock the front panel:

1. Go to the **Device Settings > General** page.
2. Click to **lock/unlock** the buttons located on the front panel.
3. Click **Save** to save the setting.

## Restarting and Resetting the Device

Two types of resets can be performed:

- Restart – Reboots your device and keeps all your device settings, including the IP address and password.
- Reset – Reboots your device and restores all factory settings including input/output definitions, switching configuration, IP address and password (a DHCP-acquired IP address is retained).

To restart the device:

- Click **DEVICE RESTART** on the **Device Settings > General** page

To perform a factory reset on the device, use one of the following actions:

- Click **FACTORY RESET** on the **Device Settings> General** page.
- Using protocol 3000 commands, send **FACTORY** command then **RESET** commands.
- On the rear panel, press and hold the **RESET** button while connecting the power for several seconds.

## Identifying Your Device

To identify the device:

1. Go to the **Device Settings > General** page
2. Click **Find Me** to send Find Me command to the matrix. The corresponding matrix will show find me information “Find me” on the LCD screen on the front panel.

The device is identified by the discovery system.

## Exporting and Importing a Configuration File

MTX3-88-HSA enables you to export and store (in connected browsing PC storage) a configuration file, that records all current device settings except the routing operation setup. The stored file can then be imported to the same or different MTX3-88-HSA device to load the recorded settings, for configuration backup and/or solution-replication purposes.

### Exporting a Configuration File

To export a configuration file of the current device settings:

1. Go to the **Device > General**.
2. Under Configuration Settings click **EXPORT**.
  - Select **Include Splash Screens** checkbox, to include the Splash Screens configurations in the export files.

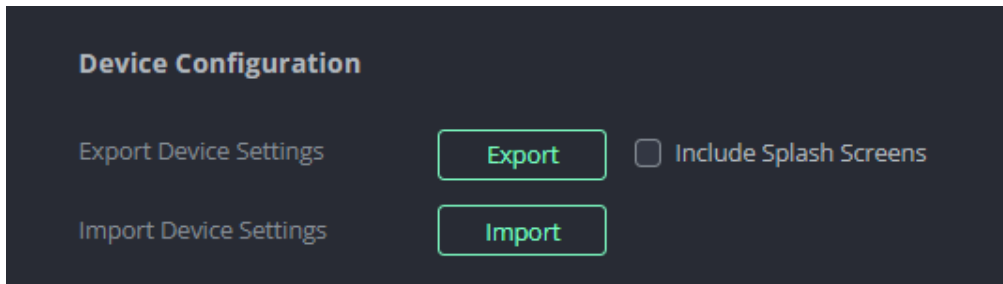

Figure 47: Device > General Page: Exporting/Importing Configuration Files

3. Select the storage location on your computer to save the configuration file and click **SAVE**.

The configuration file is exported and saved.

### Importing a Configuration File

**To import a configuration file of the current device settings:**

1. Go to the **Device > General** page.
2. Under Device Configuration Settings, click **IMPORT**.
3. Select the relevant configuration file from your computer storage and click **SAVE**.

The configuration file is imported and the device restarts with the settings from the configuration file.

### Setting the Device to Standby Mode

**To set the device to standby mode:**

1. Go to the **Device Settings > General** page.
2. Click to set the device to Standby mode (On) or exit the standby mode (Off). Default setting: Off.



The unit return to normal mode when any source is connected (any input).

## Setting Networking Properties



By default, DHCP is set to on. The IP address shows the actual IP address acquired from the DHCP server, or the auto-acquired fallback IP address when there is no DHCP server detection.

### To configure network settings:

1. Go to the **Device Settings > General** page.
2. Select the **Network** tab.

The network page appears.

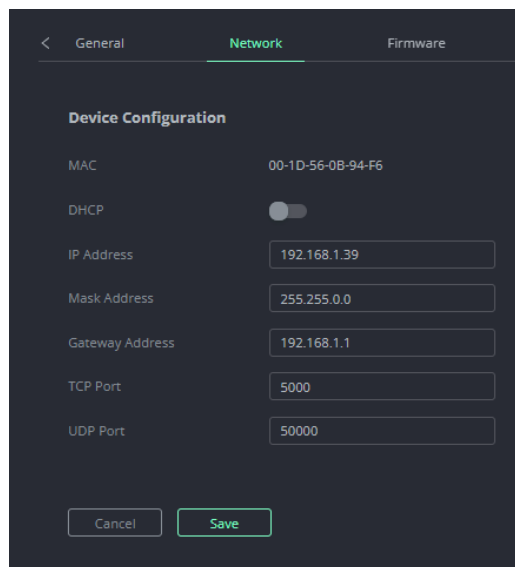

Figure 48: Device Settings > Network Page (DHCP Off)

3. Change settings as needed.  
If required, Set to **DHCP** (default) or static IP address resolution modes.
4. When in Static IP mode, perform the following actions:
  - Change the **IP Address**.
  - Change the **Mask Address**.
  - Change the **Gateway Address**.
5. Define **TCP Port** (default, 5000) and **UDP Port** (default, 50000) ports.
6. Click **Save**.

Network settings are defined.

## Upgrading Firmware

This section allows the users to upgrade and view the active FW and stored (stand-by) FW.

### To View Active and Stored Firmware

1. Go to the Device Settings > Firmware page.
2. Under the Active and Stored Firmware section, view:

- Active Firmware Upgrade Time
- Active and Stored Firmware Versions

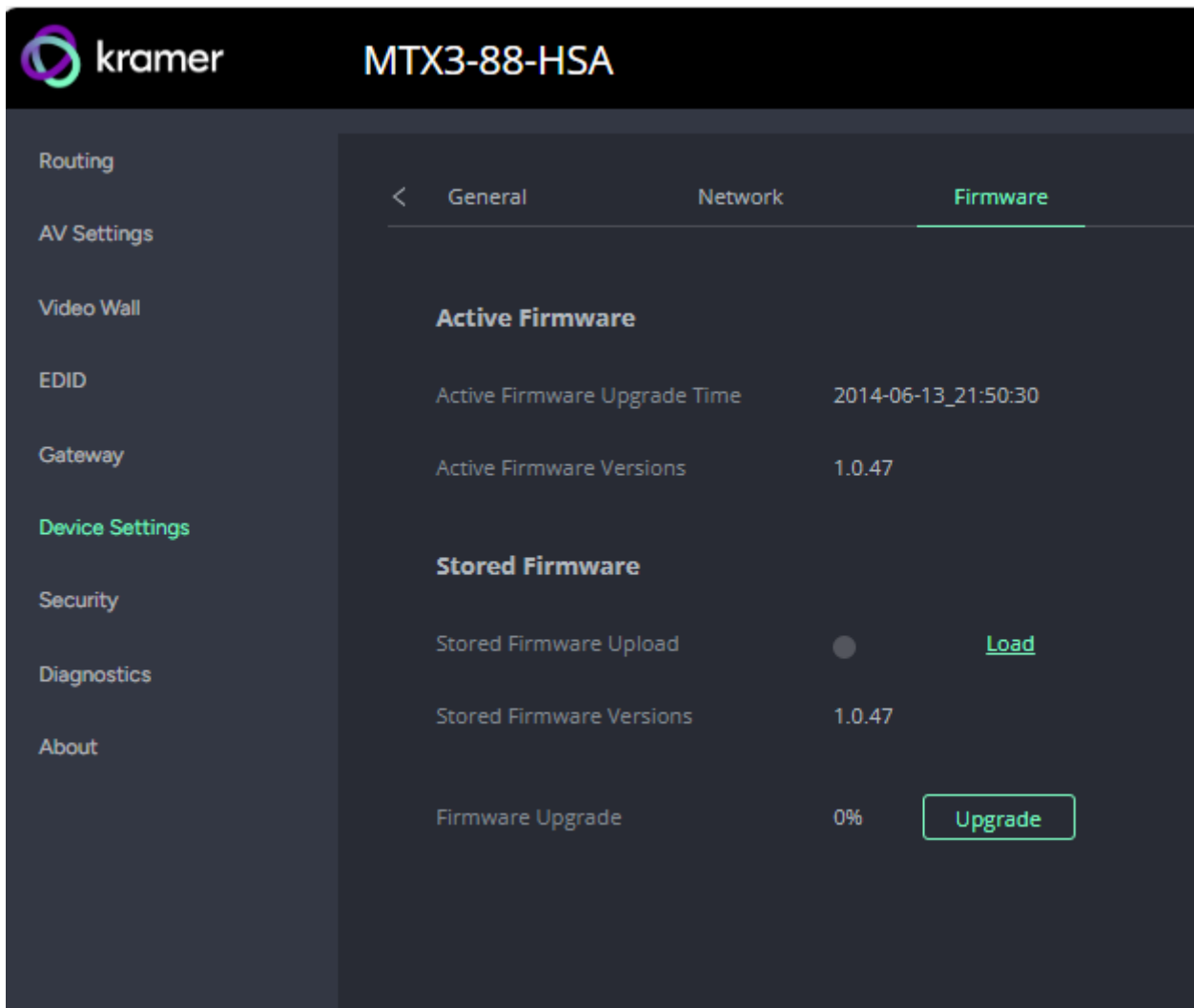

Figure 49: Device Settings &gt; Firmware Page

### To upgrade the device firmware

1. Go to the **Device Settings > Firmware** tab (Figure above).
2. In the Stored Firmware Section:
  - Click **Load** to upload the relevant FW file from the connected PC library, and follow the instructions. The upgrade takes approximately 30-60 seconds.
  - Stored Firmware Versions: Displays the uploaded and stored FW versions.
  - Firmware Upgrade: Click **Upgrade** and activate it with the stored FW (becoming the active firmware).



- Do not power off the device during the upgrade process.
- During FW upgrade, the device continues to operate, but the device UI and protocol 3000 communication are inactive. When the device restarts, the status LED is lit, and the HDMI output signal is disconnected until restart completes.
- Firmware load and upgrade are independent actions. Typically, firmware loading is done during working hours as a background process with no effect on device service, while firmware upgrading is done during maintenance time to minimize the impact on users due to the effect of upgrading on device service.

Firmware is updated.

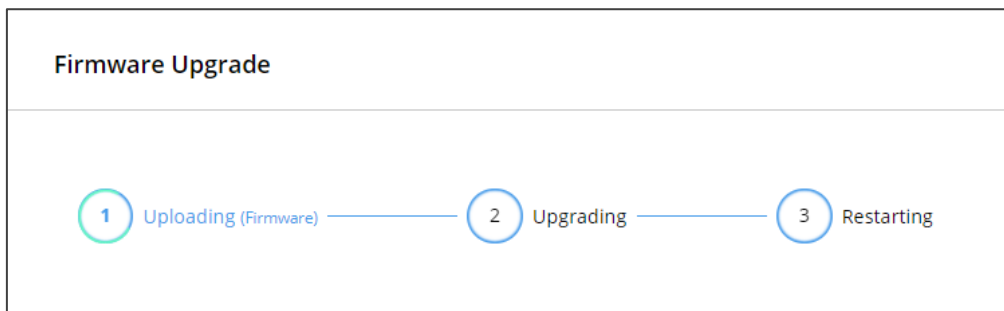

Figure 50:Firmware Upgrade Process

## Setting Time and Date

You can sync the device time and date to any server around the world.

**To sync device time and date to a server:**

1. Go to the Device Settings> General page.
7. Select the **Time and Date** tab. The Time and Date tab appears.

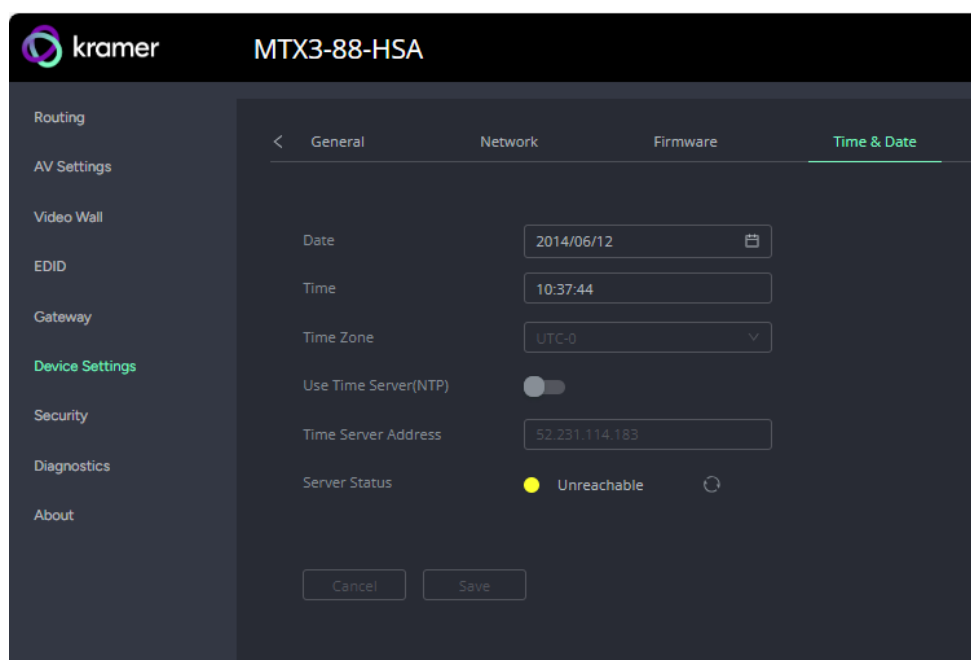

Figure 51: Device Settings – Time and Date Tab

3. Select Date and Time.
  4. Select the Time Zone.
  8. In the Use Time Server (NTP) drop-down box, click:
    - **Disabled** to disable the time server.
    - **Manual** to enable time server (NTP).
  9. If enabled, type in server information:
    - Enter the time server address.
  10. Click **SAVE** for any change.
- The devices date and time are synchronized to the server address entered.

---

## Security

### Setting Security Properties

This section details the following actions:

- [Setting Security Properties](#) on page [50](#)
- [Configuring HTTPS](#) on Page [52](#)

### Changing Security Status

By default, security status is set to On.

### Setting Security Status to Off

To set security status to Off:

1. Go to the Security page.
2. Select the Device Security tab. The Security settings appears ([Figure 52](#)).

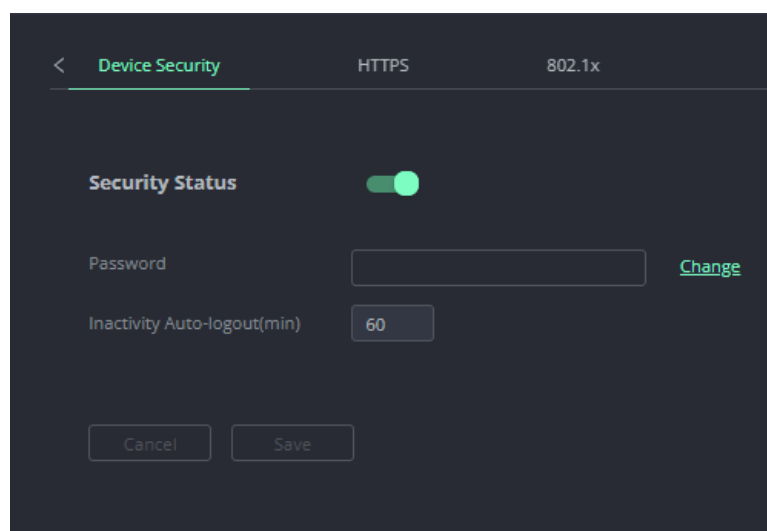

Figure 52: Security – Device Security Tab

3. Set **SECURITY STATUS** to **Off**. The Security Status window appears.

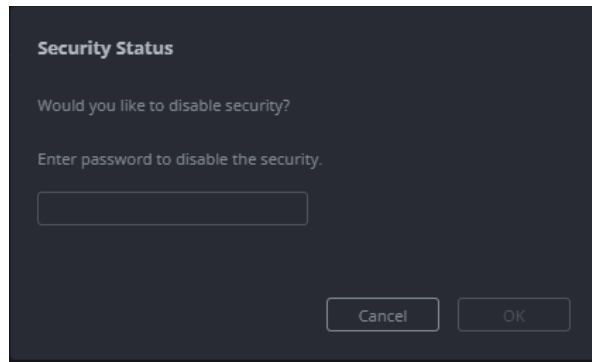

Figure 53: Security Status Message

4. Enter the current password.
5. Click **OK**.

Security status is set to Off.

### Setting Security Status to On

#### To set security status to on:

1. Go to the Security >Device Security ([Figure 52](#)).
2. Set SECURITY STATUS to **On**.

Security status is set to On.

### Setting Page's Inactivity Auto-Logout Time

#### To set inactivity auto-logout time:

1. Go to the Security >Device Security ([Figure 52](#)).
2. Click the Inactivity auto-logout(min) up/down arrows to set the time.
  - Range: 0-60
  - 0: Do not exit page
3. Click **Save**.

Auto-logout time is set.

### Changing Web Pages Access Password

#### To change the password for accessing the embedded web pages:

1. Go to the Security page ([Figure 52](#)).
2. Select the Device Security Tab. The Security settings appear ([Figure 54](#)).
3. Enter the Current Password and click **Change**. The new password settings appear.

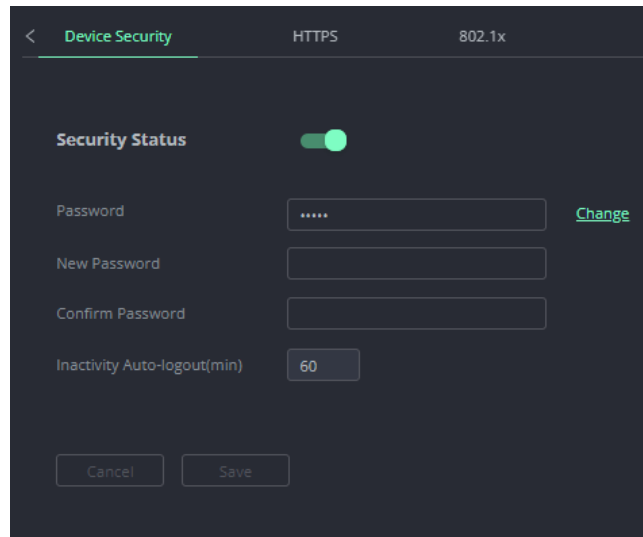

Figure 54: Device Settings – Changing the Password

4. Enter the new password and confirmation password and click **SAVE**.  
The password is changed.

## Configuring HTTPS

To configure HTTPS:

1. In the Navigation pane, click **Security**. The Device Security tab appears ([Figure 52](#)).
2. Select **HTTPS** tab.

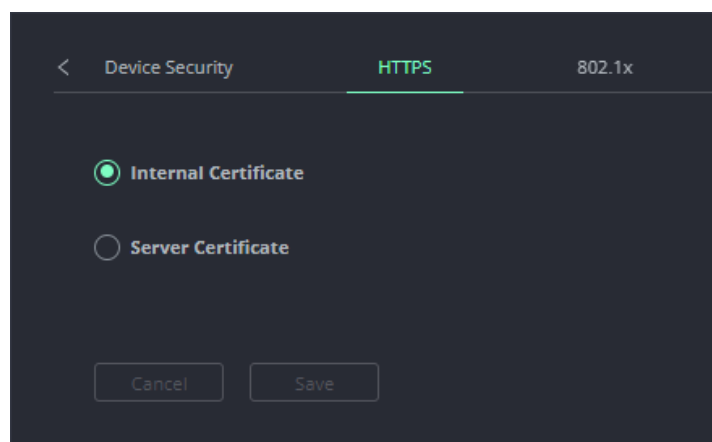



Figure 55: Security – HTTPS Tab

3. Check one of the following settings:
  - **Internal Certificate** – To use the factory default certificate for authentication.
  - **Server Certificate** – To submit certificate from the server for authentication. To do so, click to  upload the certificate. enter the private key password (assigned by the IT administrator) and click **Save**.

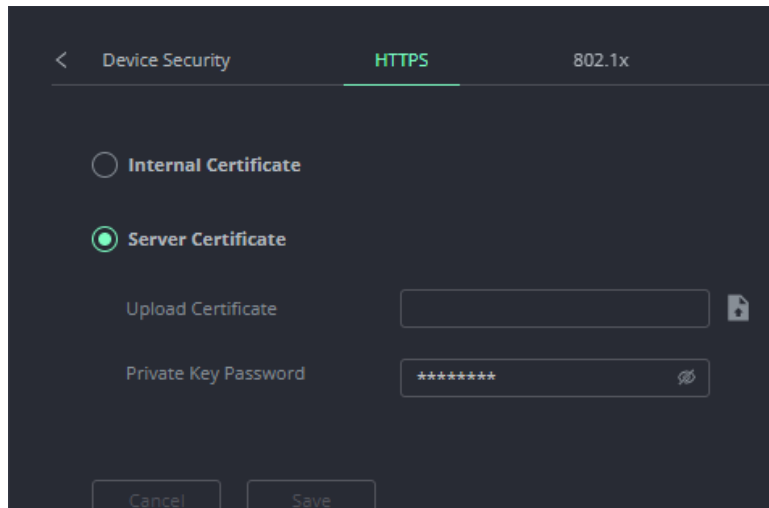

Figure 56: Security Tab – Server Certificate

HTTPS is configured.

### Defining 802.1X Authentication

802.1x security standard supports IT networking authentication based on LAN port and MAC address.

#### To configure security:

1. In the Navigation pane, click **Security**. The Security settings tab in the Security page appears.
2. Select **802.1X** tab. The 802.1X settings tab appears ([Figure 57](#)).

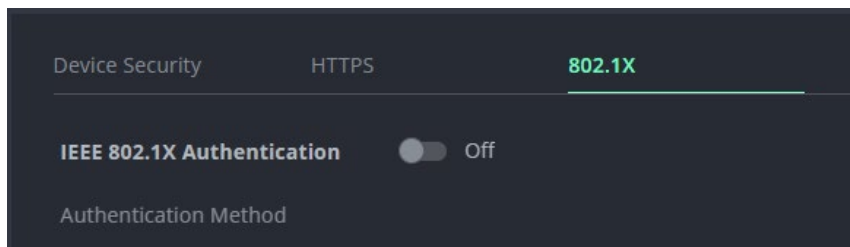

Figure 57: 802.1X Tab

3. For 802.1x authentication, click **ON** to enable 802.1x authentication service. 802.1x supports authentication based on port and MAC address.
4. When set to ON check one standard authentication method to set its security attributes.

#### **PEAP-MSCHAP V2**– Enter:

- Username - up to 24 alphanumeric characters, including “\_” and “-“ characters within the username, and
- Password - up to 24 ASCII characters

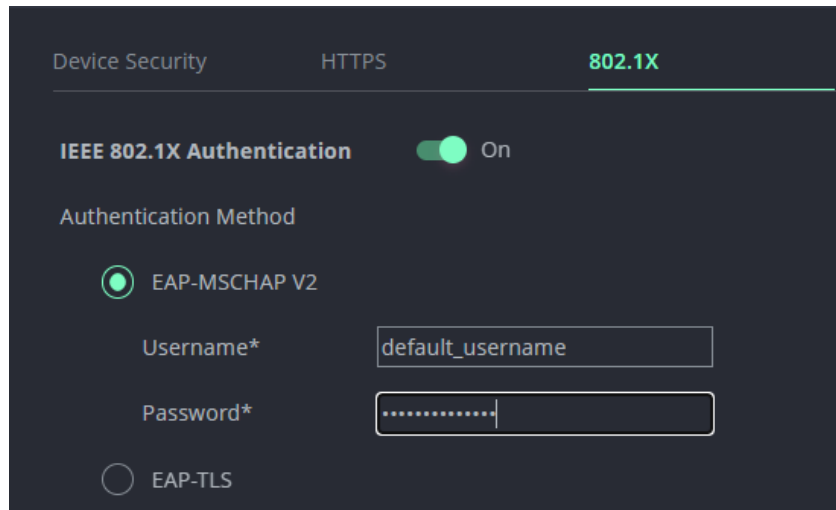



Figure 58: Security Tab – EAP-MSCHAP V2 Authentication

**EAP-TLS** – To submit certificate from the server for authentication:

- Enter Username,
- Click  to upload the certificates and keys,
- Enter the private key password (assigned by IT administrator),
- Set Server Certificate On.

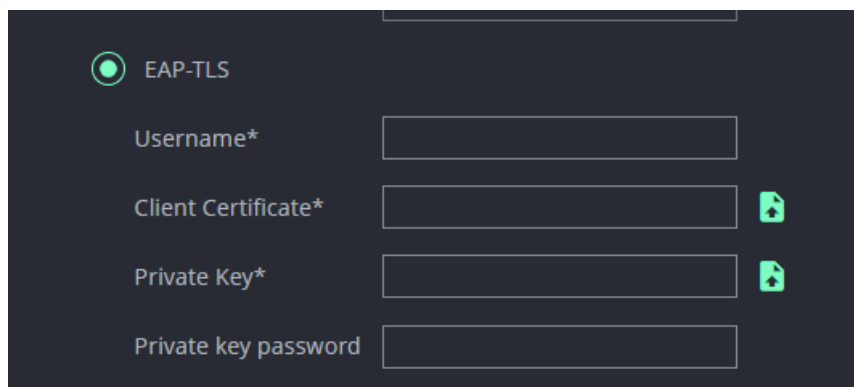

Figure 59: EAP-TLS – Certificates and Password

### Server Certificate

**CA Certificate** – Upload certificate (PEM file) to the Radius server for authentication:



The RADIUS server is responsible for handling authentication requests from network access devices and verifying user credentials against a database

**Server Certificate** – Click to set server certificate to on/off. When it is set to on, users need to submit a CA certificate for authentication.

**To submit a CA Certificate from the server:**

1. Set Server Certificate On
2. Click  to upload the certificate

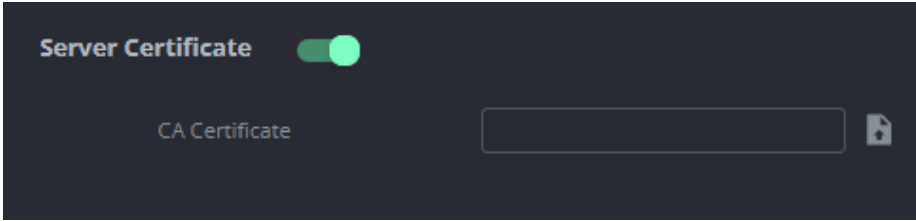

Figure 60: CA – Certificate

- 5. Click **Save**.
- 802.1x authentication security is configured.

---

## Diagnostics

This section allows user to view the system’s temperature and fan speed.

### Viewing Device’s Status

To view status device:

- 1. Go to the Diagnostics page.

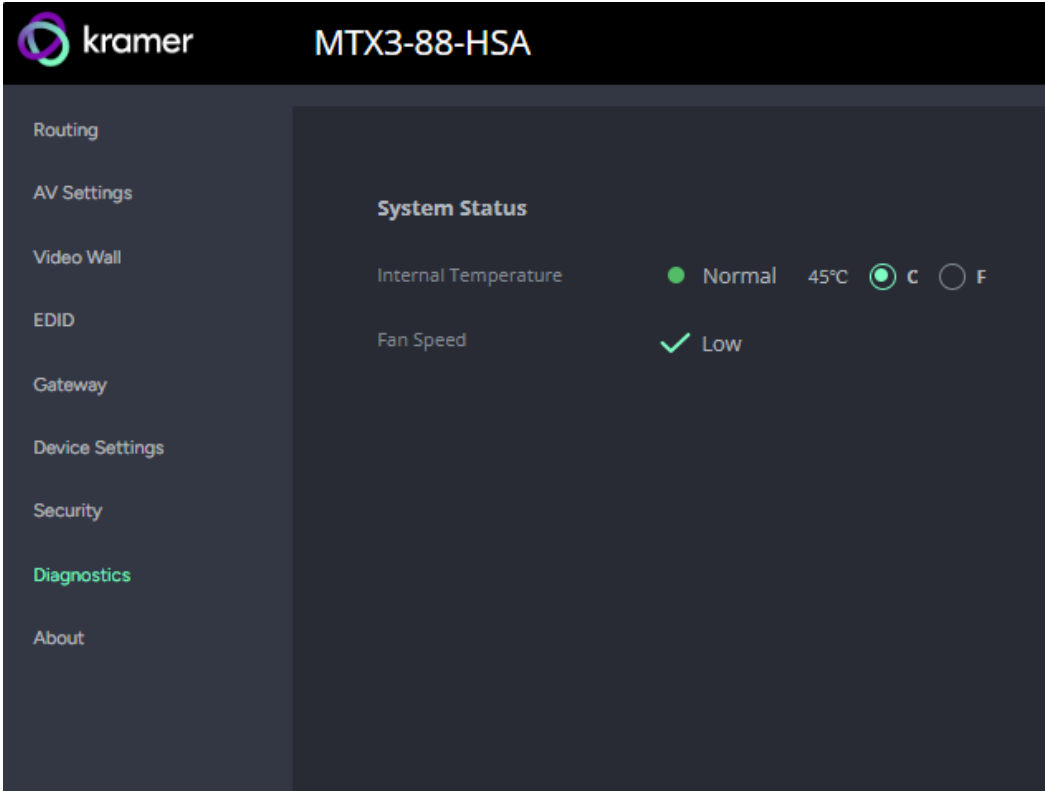

Figure 61: Diagnostics Page

- 2. View the system status:
  - **Internal Temperature:** Select C (Celsius) or F (Fahrenheit) to change the temperature display unit.
  - **Fan Speed**

# Upgrading Firmware with RS-232

Use the Kramer **K-UPLOAD** software to upgrade the firmware via ethernet or the RS-232 port, allowing RS-232 to control/program the device). The device continues to operate and once FW upload complete, you are asked to Restart no or later.

The latest version of **K-UPLOAD** and installation instructions can be downloaded from our website at: [www.kramerav.com/support/product\\_downloads.asp](http://www.kramerav.com/support/product_downloads.asp).



Note that in order to use the micro USB port, you need to install the Kramer USB driver, available at: [www.kramerav.com/support/product\\_downloads.asp](http://www.kramerav.com/support/product_downloads.asp).

# Technical Specifications

Inputs	8 HDMI	On female HDMI connectors
	8 Stereo Analog Unbalanced Audio	On 3.5mm mini jacks
Outputs	8 HDMI	On female HDMI connectors
	8 Stereo Balanced Audio	On 5-pin terminal blocks (+4dBu nominal)
Ports	1 USB	On a mini-USB connector for device firmware upgrade or management
	1 RS-232	On a 3-pin terminal block connector
	1 Ethernet	On an RJ-45 female connector for device control and management
	1 5V/2A USB	On a female USB-A connector for powering another device
Video	Max. Output Resolution	4K@60Hz (4:4:4)
	Max Data Rate	18Gbps bandwidth (6Gbps per graphic channel)
	Content Protection	HDCP 2.3
	Compliance	Deep Color, 3D, ARC, up to 7.1 uncompressed audio channels as specified in HDMI 2.0
Audio Matrix	Matrix Size	24x24
	Routable Signals	Input/output ports, breakaway forward/ARC signals
Control	Front Panel	Buttons for device operation, (for example, input/output selection)
	Indicators	7-segment display
Power	Source	100-240V AC, 50/60Hz
	Consumption	66VA
Enclosure	Size	19", 1U
	Type	Aluminum
	Cooling	Fan ventilation
	Max. Noise	46dBA
Environmental Conditions	Operating Temperature	0° to +40°C (32° to 104°F)
	Storage Temperature	-40° to +70°C (-40° to 158°F)
	Humidity	10% to 90%, RH non-condensing
General	Net Dimensions (W, D, H)	43.6cm x 18.3cm x 4.4cm (17.18" x 7.20" x 1.72")
	Shipping Dimensions (W, D, H)	52.5cm x 33cm x 10.7cm (20.7" x 13" x 4.2")
	Net Weight	2.5kg (5.5lbs) approx.
	Shipping Weight	3.4kg (7.4lbs) approx.
Accessories	Included	Rack ears, power cord
Specifications are subject to change without notice at <a href="http://www.kramerav.com">www.kramerav.com</a>		

## Default Communication Parameters

RS-232	
Baud Rate:	115,200
Data Bits:	8
Stop Bits:	1
Parity:	None
Command Format:	ASCII
Example (Route video input 2 to the output):	#ROUTE_1,1,2<CR>
Ethernet	
To reset the IP settings to the factory reset values go to: Menu->Setup -> Factory Reset-> press Enter to confirm	
Fallback IP Address:	192.168.1.39
Fallback Subnet mask:	255.255.255.0
Fallback gateway:	192.168.0.1
Default username:	Admin
Default password:	Admin
Full Factory Reset	
P3K	<p>"#FACTORY" command.</p> <p>After receiving "FACTORY OK" perform one of the following to restart the device and complete the procedure:</p> <ul style="list-style-type: none"> <li>• Power cycle</li> <li>• Send command "#RESET"</li> </ul>
Embedded webpages	Go to: Device>General and click FACTORY RESET

# Protocol 3000

Kramer devices can be operated using Kramer Protocol 3000 commands sent via serial or Ethernet ports.

## Understanding Protocol 3000

Protocol 3000 commands are a sequence of ASCII letters, structured according to the following.

- **Command format:**

Prefix	Command Name	Constant (Space)	Parameter(s)	Suffix
#	Command	_	Parameter	<CR>

- **Feedback format:**

Prefix	Device ID	Constant	Command Name	Parameter(s)	Suffix
~	nn	@	Command	Parameter	<CR><LF>

- **Command parameters** – Multiple parameters must be separated by a comma (.). In addition, multiple parameters can be grouped as a single parameter using brackets ([ and ]).
- **Command chain separator character** – Multiple commands can be chained in the same string. Each command is delimited by a pipe character (|).
- **Parameters attributes** – Parameters may contain multiple attributes. Attributes are indicated with pointy brackets (<...>) and must be separated by a period (.).

The command framing varies according to how you interface with **VS-88H2A**. The following figure displays how the # command is framed using terminal communication software (such as Hercules):

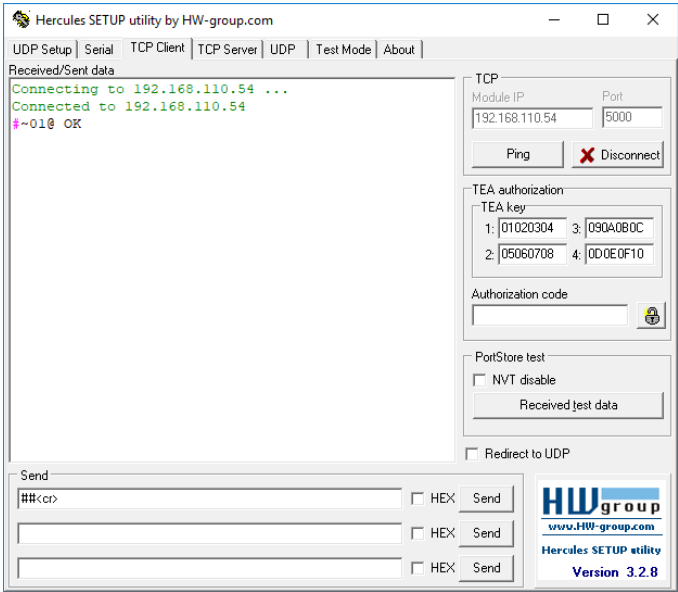

# Protocol 3000 Commands

Function	Description	Syntax	Parameters/Attributes	Example
#	Protocol handshaking.  Validates the Protocol 3000 connection and gets the machine number.  Step-in master products use this command to identify the availability of a device.	<b>COMMAND</b> <b>#&lt;CR&gt;</b>  <b>FEEDBACK</b> ~nn@_ok<CR><LF>		#<CR>
AMUTE	Mute audio on an output	<b>COMMAND</b> <b>#AMUTE_out_index,flag&lt;CR&gt;</b>  <b>FEEDBACK</b> ~nn@BALANCE_out_index,balance,flag<CR><LF>	<b>out_index</b> –Port number (typically follows printing on the panel)  1 – 8 for embedded audio 9– 12 for analog audio  <b>flag</b> – Audio Mute 0 – Audio enabled (unmuted) 1 – Audio muted	Mute the audio on Output 5: #AMUTE_5,1<CR>
AUD	LEGACY COMMAND. Set audio switch state.	<b>COMMAND</b> <b>#AUD_in&gt;out_id&lt;CR&gt;</b>  <b>FEEDBACK</b> ~nn@AUD_in>out_id<CR><LF>	<b>in</b> – Input number 0 – disconnect output 1 – HDMI IN 1 2 – HDMI IN 2 3 – HDMI IN 3 4 – HDMI IN 4 5 – HDMI IN 5  6 – HDMI IN 6 7 – HDMI IN 7 8 – HDMI IN 8 9 – Analog IN 1 10 – Analog IN 2 11 – Analog IN 3 12 – Analog IN 4 13-ARC HDMI IN1 14-ARC HDMI IN2 15-ARC HDMI IN3 16-ARC HDMI IN4 17-ARC HDMI IN5 18-ARC HDMI IN6 19-ARC HDMI IN7 20-ARC HDMI IN8  > – Connection character between in and out parameters <b>out_id</b> – Output number * – All outputs 1 – HDMI OUT 1 2 – HDMI OUT 2 3 – HDMI OUT 3 4 – HDMI OUT 4 5 – HDMI OUT 5 6 – HDMI OUT 6 7 – HDMI OUT 7 8 – HDMI OUT 8 9 – Analog OUT 1 10 – Analog OUT 2 11 – Analog OUT 3 12 – Analog OUT 4 13-ARC HDMI OUT1 14-ARC HDMI OUT2 15-ARC HDMI OUT3 16-ARC HDMI OUT4 17-ARC HDMI OUT5 18-ARC HDMI OUT6 19-ARC HDMI OUT7 20-ARC HDMI OUT8	Switch embedded audio HDMI IN 1 to HDMI OUT 3: #AUD_1>3<CR>
AUD?	LEGACY COMMAND. Get audio switch state.	<b>COMMAND</b> <b>#AUD?_out_id&lt;CR&gt;</b>  <b>FEEDBACK</b> ~nn@AUD_in>out_id<CR><LF>	<b>in</b> – Input number 1 – HDMI IN 1 2 – HDMI IN 2 3 – HDMI IN 3 4 – HDMI IN 4 5 – HDMI IN 5 6 – HDMI IN 6 7 – HDMI IN 7 8 – HDMI IN 8 9 – Analog IN 1	Get audio switch state for HDMI OUT 3: #AUD?_3<CR>

Function	Description	Syntax	Parameters/Attributes	Example
			10 – Analog IN 2 11 – Analog IN 3 12– Analog IN 4 13-ARC HDMI IN1 14-ARC HDMI IN2 15-ARC HDMI IN3 16-ARC HDMI IN4 17-ARC HDMI IN5 18-ARC HDMI IN6 19-ARC HDMI IN7 20-ARC HDMI IN8  > – Connection character between in and out parameters out_id – Output number * – All outputs 1– HDMI OUT 1 2– HDMI OUT 2 3– HDMI OUT 3 4– HDMI OUT 4 5– HDMI OUT 5 6– HDMI OUT 6 7– HDMI OUT 7 8– HDMI OUT 8 9– Analog OUT 1 10 – Analog OUT 2 11 – Analog OUT 3 12– Analog OUT 4 13-ARC HDMI OUT1 14-ARC HDMI OUT2 15-ARC HDMI OUT3 16-ARC HDMI OUT4 17-ARC HDMI OUT5 18-ARC HDMI OUT6 19-ARC HDMI OUT7 20-ARC HDMI OUT8	
AV	Switch audio and video.	<b>COMMAND</b> #AV_in>out_id,in>out_id,...<CR> <b>FEEDBACK</b> ~nn@AV_in>out_id,in>out_id,...<CR><LF>	in – Number that indicates the specific input: 0 – disconnect output 1 – HDMI IN 1 2– HDMI IN 2 3– HDMI IN 3 4– HDMI IN 4 5– HDMI IN 5 6– HDMI IN 6 7– HDMI IN 7 8– HDMI IN 8  > – Connection character between in and out parameters out_id –Output number * – All outputs 1– HDMI OUT 1 2– HDMI OUT 2 3– HDMI OUT 3 4– HDMI OUT 4 5– HDMI OUT 5 6– HDMI OUT 6 7– HDMI OUT 7 – HDMI OUT 8	Switch IN 1 to OUT 4: #AV_1>4<CR>
BALANCE	Set balance level.	<b>COMMAND</b> #BALANCE_out_index,balance_level<CR> <b>FEEDBACK</b> ~nn@BALANCE_out_index,balance_level<CR><LF>	out_index – Number that indicates the specific output: 1– Analog OUT 1 2– Analog OUT 2 3– Analog OUT 3 4– Analog OUT 4  balance_level – 0 to 100;	Set the speaker output balance to +12: #BALANCE_1,12<CR>
BALANCE?	Get balance level.	<b>COMMAND</b> #BALANCE?_out_index<CR> <b>FEEDBACK</b> ~nn@BALANCE_out_index,balance_level<CR><LF>	out_index – Number that indicates the specific output: 2– Analog OUT 1 3– Analog OUT 2 4– Analog OUT 3 5– Analog OUT 4  balance_level – 0 to 100	Get balance level for channel 1: #BALANCE?_1<CR>
BAUD	Set protocol serial port baud rate.   The new defined baud rate is stored in the	<b>COMMAND</b> #BAUD_baud_rate<CR> <b>FEEDBACK</b> ~nn@BAUD_baud_rate<CR><LF>	baud_rate – 9600 / 115200 /19200/38400/57600	Set the baud rate to 9600: #BAUD_9600<CR>

Function	Description	Syntax	Parameters/Attributes	Example
	<p>EEPROM and used when powering up.</p> <p>Default baud rate is 115200 (on factory reset).</p> <p>Only works with devices supporting this command (if ERR 002 is returned, the default baud rate is used).</p>			
BAUD?	<p>Get protocol serial port baud rate. (Option 1 - for current baud rate. Option 2 - for list of supported baud rates).</p> <p><b>i</b> The new defined baud rate is stored in the EEPROM and used when powering up.</p> <p>Default baud rate is 115200 (on factory reset).</p> <p>Only works with devices supporting this command (if ERR 002 is returned, the default baud rate is used).</p>	<p><b>COMMAND</b></p> <p>#BAUD?_&lt;CR&gt;</p> <p><b>FEEDBACK</b></p> <p>~nn@BAUD_baud_rate&lt;CR&gt;&lt;LF&gt;</p>	<p>baud_rate – 9600 / 115200 / 19200/38400/57600</p>	<p>Get protocol serial port baud rate:</p> <p>#BAUD?_&lt;CR&gt;</p>
BUILD- DATE?	<p>Get device build date.</p>	<p><b>COMMAND</b></p> <p>#BUILD-DATE?_&lt;CR&gt;</p> <p><b>FEEDBACK</b></p> <p>~nn@BUILD-DATE_date,time&lt;CR&gt;&lt;LF&gt;</p>	<p>date – Format: YYYY/MM/DD where YYYY = Year MM = Month DD = Day</p> <p>time – Format: hh:mm:ss where hh = hours mm = minutes ss = seconds</p>	<p>Get the device build date:</p> <p>#BUILD-DATE?&lt;CR&gt;</p>
CPEDID	<p>Copy EDID data from the output to the input EEPROM.</p> <p><b>i</b> Destination bitmap size depends on device properties (for 64 inputs it is a 64-bit word).</p> <p>Example: bitmap 0x0013 means inputs 1,2 and 5 are loaded with the new EDID.</p> <p>In certain products Safe_mode is an optional parameter. See the HELP command for its availability.</p>	<p><b>COMMAND</b></p> <p>#CPEDID_edid_io,src_id,dst_type,dest_bitmap&lt;CR&gt;</p> <p>or</p> <p>#CPEDID_edid_io,src_id,dst_type,dest_bitmap,safe_mode&lt;CR&gt;</p> <p><b>FEEDBACK</b></p> <p>~nn@CPEDID_edid_io,src_id,dst_type,dest_bitmap&lt;CR&gt;&lt;LF&gt;</p> <p>~nn@CPEDID_edid_io,src_id,dst_type,dest_bitmap,safe_mode&lt; CR&gt;&lt;LF&gt;</p>	<p>edid_io – EDID source type (usually output)</p> <p>0 – Input 1 – Output 2 – Default EDID</p> <p>src_id – Number of chosen source stage</p> <p>For input source: 1 – HDMI IN 1 2 – HDMI IN 2 3 – HDMI IN 3 4 – HDMI IN 4 5 – HDMI IN 5 6 – HDMI IN 6 7 – HDMI IN 7 8 – HDMI IN 8</p> <p>For output source: 0 – Default EDIDsource 1 – HDMI OUT 1 2 – HDMI OUT 2 3 – HDMI OUT 3 4 – HDMI OUT 4 5 – HDMI OUT 5 6 – HDMI OUT 6 7 – HDMI OUT 7 8 – HDMI OUT 8</p> <p>dst_type – EDID destination type (usually input)</p> <p>0 – Input</p> <p>dest_bitmap – Bitmap representing destination IDs. Format: XXXX...X, where X is hex digit. The binary form of every hex digit represents corresponding destinations.</p> <p>0 – indicates that EDID data is not copied to this destination. 1 – indicates that EDID data is copied to this destination.</p> <p>safe_mode – Safe mode</p> <p>0 – device accepts the EDID as is without trying to adjust</p>	<p>Copy the EDID data from the Output 1 (EDID source) to the Input:</p> <p>#CPEDID_1,1,0,0x1&lt;CR&gt;</p> <p>Copy the EDID data from the default EDID source to the Input:</p> <p>#CPEDID_2,0,0,0x1&lt;CR&gt;</p>

Function	Description	Syntax	Parameters/Attributes	Example
			1 – device tries to adjust the EDID (default value if no parameter is sent)	
DIR	List files in device.	<b>COMMAND</b> <b>#DIR&lt;CR&gt;</b> <b>FEEDBACK</b> Multi-line: ~nn@DIR<CR><LF> file_name TABfile_size_bytes,id:_file_id<CR><LF> TABfree_size_bytes.<CR><LF>	<b>file_name</b> – Name of file <b>file_size</b> – File size in bytes. A file can take more space on device memory <b>file_id</b> – Internal ID for file in file system <b>free_size</b> – Free space in bytes in device file system	<b>#DIR&lt;CR&gt;</b>
DISPLAY?	Get output HPD status.	<b>COMMAND</b> <b>#DISPLAY?_out_index&lt;CR&gt;</b> <b>FEEDBACK</b> ~nn@DISPLAY_out_index,status<CR><LF>	<b>out_index</b> – Number that indicates the specific output: 1 – HDMI OUT 1 2 – HDMI OUT 2 3 – HDMI OUT 3 4 – HDMI OUT 4 5 – HDMI OUT 5 6 – HDMI OUT 6 7 – HDMI OUT 7 8 – HDMI OUT 8 <b>status</b> – HPD status according to signal validation 0 – Signal or sink is not valid 1 – Signal or sink is valid 2 – Sink and EDID is valid	Get the output HPD status of HDMI OUT 1: <b>#DISPLAY?_1&lt;CR&gt;</b>
ETH-PORT	Set Ethernet port protocol.  ⓘ If the port number you enter is already in use, an error is returned. The port number must be within the following range: 0-(2 <sup>16</sup> -1).	<b>COMMAND</b> <b>#ETH-PORT_port_type,port_id&lt;CR&gt;</b> <b>FEEDBACK</b> ~nn@ETH-PORT_port_type,port_id<CR><LF>	<b>port_type</b> – TCP/UDP <b>port_id</b> – TCP/UDP port number (2000 – 65535)	Set the Ethernet port protocol for TCP to port 12457: <b>#ETH-PORT_TCP,12457&lt;CR&gt;</b>
ETH-PORT?	Get Ethernet port protocol.	<b>COMMAND</b> <b>#ETH-PORT?_port_type&lt;CR&gt;</b> <b>FEEDBACK</b> ~nn@ETH-PORT_port_type,port_id<CR><LF>	<b>port_type</b> – TCP/UDP <b>port_id</b> – TCP / UDP port number (2000 – 65535)	Get the Ethernet port protocol for UDP: <b>#ETH-PORT?_UDP&lt;CR&gt;</b>
FACTORY	Reset device to factory default configuration.  ⓘ This command deletes all user data from the device. The deletion can take some time.  Your device may require powering off and powering on for the changes to take effect.	<b>COMMAND</b> <b>#FACTORY&lt;CR&gt;</b> <b>FEEDBACK</b> ~nn@FACTORY_ok<CR><LF>		Reset the device to factory default configuration: <b>#FACTORY&lt;CR&gt;</b>
FPGA-VER?	Get current FPGA version.	<b>COMMAND</b> <b>#FPGA-VER?_fpga_id&lt;CR&gt;</b> <b>FEEDBACK</b> ~nn@FPGA-VER_fpga_id,expected_ver,ver<CR><LF>	<b>fpga_id</b> – FPGA id 0 <b>expected_ver</b> – Expected FPGA version for current firmware <b>ver</b> – Actual FPGA version	Get current FPGA version: <b>#FPGA-VER?_0&lt;CR&gt;</b>
GEDID	Get EDID support on certain input/output.  ⓘ For old devices that do not support this command, ~nn@ERR 002<CR><LF> is received.	<b>COMMAND</b> <b>#GEDID_io_mode,in_index&lt;CR&gt;</b> <b>FEEDBACK</b> ~nn@GEDID_io_mode,in_index,size<CR><LF>	<b>io_mode</b> – Input/Output 0 – Input 1 – Output 2 – Default EDID <b>in_index</b> – Number that indicates the specific input: 1 – HDMI IN 1 2 – HDMI IN 2 3 – HDMI IN 3 4 – HDMI IN 4 5 – HDMI IN 5 6 – HDMI IN 6 7 – HDMI IN 7 8 – HDMI IN 8 <b>size</b> – Size of data to be sent from device, 0 means no EDID support	Get EDID support information for input 1: <b>#GEDID_0,1&lt;CR&gt;</b>
HDCP-MOD	Set HDCP mode.  ⓘ Set HDCP working mode on the device input:	<b>COMMAND</b> <b>#GEDID_io_mode,in_index&lt;CR&gt;</b> <b>FEEDBACK</b> ~nn@GEDID_io_mode,in_index,size<CR><LF>	<b>in_index</b> – Number that indicates the specific input: 1 – HDMI IN 1 2 – HDMI IN 2	Set the input HDCP-MODE of HDMI IN 1 to Off: <b>#HDCP-MOD_1,0&lt;CR&gt;</b>

Function	Description	Syntax	Parameters/Attributes	Example
	<p>HDCP supported - HDCP_2.2 [default]/HDCP_1.4.</p> <p>HDCP not supported - HDCP OFF.</p>		<p>3– HDMI IN 3 4– HDMI IN 4 5– HDMI IN 5 6– HDMI IN 6 7– HDMI IN 7 8– HDMI IN 8</p> <p><b>mode</b> – HDCP mode: 0 – HDCP Off 1 – HDCP1.4 2 – HDCP2.2</p>	
HDCP-MOD?	<p>Get HDCP mode.</p> <p><b>i</b> Set HDCP working mode on the device input:</p> <p>HDCP supported - HDCP_2.2 [default]/HDCP_1.4.</p> <p>HDCP not supported - HDCP OFF.</p>	<p><b>COMMAND</b> #HDCP-MOD?_in_index&lt;CR&gt; <b>FEEDBACK</b> ~nn@HDCP-MOD_in_index,mode&lt;CR&gt;&lt;LF&gt;</p>	<p><b>in_index</b> – Number that indicates the specific input: 1– HDMI IN 1 2– HDMI IN 2 3– HDMI IN 3 4– HDMI IN 4 5– HDMI IN 5 6– HDMI IN 6 7– HDMI IN 7 8– HDMI IN 8</p> <p><b>mode</b> – HDCP mode: 0 – HDCP Off 1 – HDCP1.4 2 – HDCP2.2</p>	<p>Get the input HDCP-MODE of HDMI IN 1: #HDCP-MOD?_1&lt;CR&gt;</p>
HDCP- STAT?	<p>Get HDCP signal status.</p> <p><b>i</b> io_mode =1 – get the HDCP signal status of the sink device connected to the specified output.</p> <p>io_mode =0 – get the HDCP signal status of the source device connected to the specified input.</p>	<p><b>COMMAND</b> #HDCP-STAT?_io_mode,in_index&lt;CR&gt; <b>FEEDBACK</b> ~nn@HDCP-STAT_io_mode,in_index,status&lt;CR&gt;&lt;LF&gt;</p>	<p><b>io_mode</b> – Input/Output 0 – Input 1 – Output</p> <p><b>in_index</b> – Number that indicates the specific input: 1– HDMI IN 1 2– HDMI IN 2 3– HDMI IN 3 4– HDMI IN 4 5– HDMI IN 5 6– HDMI IN 6 7– HDMI IN 7 8– HDMI IN 8</p> <p><b>status</b> – Signal encryption status - valid values On/Off OFF– HDCP Off ON– HDCP On</p>	<p>Get the output HDCP-STATUS of HDMI IN 1: #HDCP-STAT?_0,1&lt;CR&gt;</p>
HELP	<p>Get command list or help for specific command.</p>	<p><b>COMMAND</b> #HELP&lt;CR&gt; <b>FEEDBACK</b> Multi-line: ~nn@Device_cmd_name,_cmd_name..&lt;CR&gt;&lt;LF&gt;</p>	<p><b>cmd_name</b> – Name of a specific command</p>	<p>Get the command list: #HELP&lt;CR&gt;</p>
IDV	<p>Set visual indication from device.</p> <p><b>i</b> Using this command, some devices can light a sequence of buttons or LEDs to allow identification of a specific device from similar devices.</p>	<p><b>COMMAND</b> #IDV&lt;CR&gt; <b>FEEDBACK</b> ~nn@IDV_ok&lt;CR&gt;&lt;LF&gt;</p>		<p>#IDV&lt;CR&gt;</p>
INFO-IO?	<p>LEGACY COMMAND. Get in/out count.</p>	<p><b>COMMAND</b> #INFO-IO?_in_count,out_count&lt;CR&gt; <b>FEEDBACK</b> ~nn@INFO-IO_in_count,OUT_out_count&lt;CR&gt;&lt;LF&gt;</p>	<p><b>in_count</b> – Number of inputs in the unit <b>out_count</b> – Number of outputs in the unit</p>	<p>Get inputs count: #INFO-IO?_in_count,out_count&lt;CR&gt;</p>
LOCK-FP	<p>Lock the front panel.</p>	<p><b>COMMAND</b> #LOCK-FP_lock/unlock&lt;CR&gt; <b>FEEDBACK</b> ~nn@LOCK-FP_lock/unlock&lt;CR&gt;&lt;LF&gt;</p>	<p><b>lock/unlock</b> unlock –unlock front panel lock –lock front panel</p>	<p>Unlock front panel: #LOCK-FP_unlock&lt;CR&gt;</p>
LOCK-FP?	<p>Get the front panel lock state.</p>	<p><b>COMMAND</b> #LOCK-FP?_lock/unlock&lt;CR&gt; <b>FEEDBACK</b> ~nn@LOCK-FP_lock/unlock&lt;CR&gt;&lt;LF&gt;</p>	<p><b>lock/unlock</b> unlock –unlock front panel lock –lock front panel</p>	<p>Get the front panel lock state: #LOCK-FP?_lock/unlock&lt;CR&gt;</p>
MODEL?	<p>Get device model.</p> <p><b>i</b> This command identifies equipment connected to VS-88HZA and notifies of identity changes to the connected equipment. The Matrix saves this data in memory to</p>	<p><b>COMMAND</b> #MODEL?_model_name&lt;CR&gt; <b>FEEDBACK</b> ~nn@MODEL_model_name&lt;CR&gt;&lt;LF&gt;</p>	<p><b>model_name</b> – String of up to 19 printable ASCII chars</p>	<p>Get the device model: #MODEL?_model_name&lt;CR&gt;</p>

Function	Description	Syntax	Parameters/Attributes	Example
	answer REMOTE-INFO requests.			
<b>NAME</b>	Set machine (DNS) name. <i>i</i> The machine name is not the same as the model name. The machine name is used to identify a specific machine or a network in use (with DNS feature on).	<b>COMMAND</b> <b>#NAME_machine_name&lt;CR&gt;</b> <b>FEEDBACK</b> ~nn@NAME_machine_name<CR><LF>	<b>machine_name</b> – String of up to 14 alphanumeric chars (can include hyphen, not at the beginning or end)	Set the DNS name of the device to room-442: <b>#NAME_room-442&lt;CR&gt;</b>
<b>NAME?</b>	Get machine (DNS) name. <i>i</i> The machine name is not the same as the model name. The machine name is used to identify a specific machine or a network in use (with DNS feature on).	<b>COMMAND</b> <b>#NAME?_&lt;CR&gt;</b> <b>FEEDBACK</b> ~nn@NAME_machine_name<CR><LF>	<b>machine_name</b> – String of up to 14 alphanumeric chars (can include hyphen, not at the beginning or end)	Get the DNS name of the device: <b>#NAME?_&lt;CR&gt;</b>
<b>NAME-RST</b>	Reset machine (DNS) name to factory default. <i>i</i> Factory default of machine (DNS) name is "MTX3-88-HAS-" + 8 last digits of device mac number.	<b>COMMAND</b> <b>#NAME-RST&lt;CR&gt;</b> <b>FEEDBACK</b> ~nn@NAME-RST_ok<CR><LF>		Reset the machine name (mac last digits are 65-5a-e9): <b>#NAME-RST_ MTX3-88-HSA-65-5a-e9&lt;CR&gt;</b>
<b>NET-DHCP</b>	Set DHCP mode. <i>i</i> Only 1 is relevant for the mode value. To disable DHCP, the user must configure a static IP address for the device. Connecting Ethernet to devices with DHCP may take more time in some networks. To connect with a randomly assigned IP by DHCP, specify the device DNS name (if available) using the <b>NAME</b> command. You can also get an assigned IP by direct connection to USB or RS-232 protocol port, if available. For proper settings consult your network administrator. <i>i</i> For Backward compatibility, the <b>id</b> parameter can be omitted. In this case, the Network ID, by default, is 0, which is the Ethernet control port.	<b>COMMAND</b> <b>#NET-DHCP_dhcp_state&lt;CR&gt;</b> <b>FEEDBACK</b> ~nn@NET-DHCP_dhcp_state<CR><LF>	<b>dhcp_state</b> – 1 – Try to use DHCP. (If unavailable, use the IP address set by the factory or the <b>net-ip</b> command).	Enable DHCP mode for port 1, if available: <b>#NET-DHCP_1&lt;CR&gt;</b>
<b>NET-DHCP?</b>	Get DHCP mode. <i>i</i> For Backward compatibility, the <b>id</b> parameter can be omitted. In this case, the Network ID, by default, is 0, which is the Ethernet control port.	<b>COMMAND</b> <b>#NET-DHCP?_&lt;CR&gt;</b> <b>FEEDBACK</b> ~nn@NET-DHCP dhcp_mode<CR><LF>	<b>dhcp_mode</b> – 0 – Do not use DHCP. Use the IP set by the factory or using the <b>net-ip</b> or <b>net-config</b> command. 1 – Try to use DHCP. If unavailable, use the IP set by the factory or using the <b>net-ip</b> or <b>net-config</b> command.	Get DHCP mode for port 1: <b>#NET-DHCP?&lt;CR&gt;</b>
<b>NET-GATE</b>	Set gateway IP. <i>i</i> A network gateway connects	<b>COMMAND</b> <b>#NET-GATE_ip_address&lt;CR&gt;</b> <b>FEEDBACK</b>	<b>ip_address</b> – Format: xxx.xxx.xxx.xxx	Set the gateway IP address to 192.168.0.1: <b>#NET-</b>

Function	Description	Syntax	Parameters/Attributes	Example
	the device via another network and maybe over the Internet. Be careful of security issues. For proper settings consult your network administrator.	~nn@NET-GATE_ ip_address<CR><LF>		GATE_192.168.000.001<CR><LF>>
NET-GATE?	Get gateway IP. ⓘ A network gateway connects the device via another network and maybe over the Internet. Be aware of security problems.	<b>COMMAND</b> #NET-GATE?_<CR> <b>FEEDBACK</b> ~nn@NET-GATE_ ip_address<CR><LF>	ip_address – Format: xxx.xxx.xxx.xxx	Get the gateway IP address: #NET-GATE?_<CR>
NET-IP	Set IP address. ⓘ For proper settings consult your network administrator.	<b>COMMAND</b> #NET-IP_ ip_address<CR> <b>FEEDBACK</b> ~nn@NET-IP_ ip_address<CR><LF>	ip_address – Format: xxx.xxx.xxx.xxx	Set the IP address to 192.168.1.39: #NET-IP_192.168.001.039<CR>
NET-IP?	Get IP address.	<b>COMMAND</b> #NET-IP?_<CR> <b>FEEDBACK</b> ~nn@NET-IP_ ip_address<CR><LF>	ip_address – Format: xxx.xxx.xxx.xxx	Get the IP address: #NET-IP?_<CR>
NET-MAC?	Get MAC address. ⓘ For backward compatibility, the id parameter can be omitted. In this case, the Network ID, by default, is 0, which is the Ethernet control port.	<b>COMMAND</b> #NET-MAC?<CR> <b>FEEDBACK</b> ~nn@NET-MAC_ mac_address<CR><LF>	mac_address – Unique MAC address. Format: XX-XX-XX-XX-XX-XX where X is hex digit	#NET-MAC?<CR>
NET-MASK	Set subnet mask. ⓘ For proper settings consult your network administrator.	<b>COMMAND</b> #NET-MASK_ net_mask<CR> <b>FEEDBACK</b> ~nn@NET-MASK_ net_mask<CR><LF>	net_mask – Format: xxx.xxx.xxx.xxx	Set the subnet mask to 255.255.0.0: #NET-MASK_255.255.000.000<CR><LF>>
NET-MASK?	Get subnet mask.	<b>COMMAND</b> #NET-MASK?_<CR> <b>FEEDBACK</b> ~nn@NET-MASK_ net_mask<CR><LF>	net_mask – Format: xxx.xxx.xxx.xxx	Get the subnet mask: #NET-MASK?<CR>
PROT-VER?	Get device protocol version.	<b>COMMAND</b> #PROT-VER?_<CR> <b>FEEDBACK</b> ~nn@PROT-VER_3000:version<CR><LF>	version – XX.XX where X is a decimal digit	Get the device protocol version: #PROT-VER?_<CR>
PRST-RCL	Recall saved preset list. ⓘ In most units, video and audio presets with the same number are stored and recalled together by commands #PRST-STO and #PRST-RCL.	<b>COMMAND</b> #PRST-RCL_ preset<CR> <b>FEEDBACK</b> ~nn@PRST-RCL_ preset<CR><LF>	preset – Preset number	Recall preset 1: #PRST-RCL_1<CR>
PRST-STO	Store current connections, volumes and modes in preset. ⓘ In most units, video and audio presets with the same number are stored and recalled together by commands #PRST-STO and #PRST-RCL.	<b>COMMAND</b> #PRST-STO_ preset<CR> <b>FEEDBACK</b> ~nn@PRST-STO_ preset<CR><LF>	preset – Preset number	Store preset 1: #PRST-STO_1<CR>
RESET	ⓘ To avoid locking the port due to a USB bug in Windows, disconnect USB connections immediately after running this command. If the port was locked, disconnect and reconnect the cable to reopen the port.	<b>COMMAND</b> #RESET<CR> <b>FEEDBACK</b> ~nn@RESET_ ok<CR><LF>		Reset the device: #RESET<CR>
SECUR	Start/stop security. ⓘ The permission	<b>COMMAND</b> #SECUR_ security_state<CR>	security_state – Security state 0 – OFF (disables security)	Enable the permission system: #SECUR_1<CR>

Function	Description	Syntax	Parameters/Attributes	Example
	system works only if security is enabled with the "SECUR" command.	<b>FEEDBACK</b> ~nn@SECUR_security_state<CR><LF>	1 – ON (enables security)	
SECUR?	Get current security state. ⓘ The permission system works only if security is enabled with the "SECUR" command.	<b>COMMAND</b> #SECUR?_<CR> <b>FEEDBACK</b> ~nn@SECUR_security_state<CR><LF>	<b>security_state</b> – Security state 0 – OFF (disables security) 1 – ON (enables security)	Get current security state: #SECUR?_<CR>
SIGNAL?	Get input signal status.	<b>COMMAND</b> #SIGNAL?_in_index<CR> <b>FEEDBACK</b> ~nn@SIGNAL_in_index,status<CR><LF>	<b>in_index</b> – Number that indicates the specific input: 1 – HDMI IN 1 2 – HDMI IN 2 3 – HDMI IN 3 4 – HDMI IN 4 5 – HDMI IN 5 6 – HDMI IN 6 7 – HDMI IN 7 8 – HDMI IN 8 <b>status</b> – Signal status according to signal validation: 0 – Off 1 – On	Get the input signal lock status of IN 1: #SIGNAL?_1<CR>
SN?	Get device serial number	<b>COMMAND</b> #SN?_<CR> <b>FEEDBACK</b> ~nn@SN_serial_num<CR><LF>	<b>serial_num</b> – 14 decimal digits, factory assigned	Get the device serial number: #SN?_<CR>
VERSION?	Get firmware version number.	<b>COMMAND</b> #VERSION?_<CR> <b>FEEDBACK</b> ~nn@VERSION_firmware_version<CR><LF>	<b>firmware_version</b> – XX.XX.XXXX where the digit groups are: major.minor.build version	Get the device firmware version number: #VERSION?_<CR>
VID	LEGACY COMMAND. Set video switch state. ⓘ The GET command identifies input switching on Step-in clients. The SET command is for remote input switching on Step-in clients (essentially via by the Web). This is a legacy command. New Step-in modules support the ROUTE command.	<b>COMMAND</b> #VID_in_id>out_id<CR> <b>FEEDBACK</b> ~nn@VID_in_id>out_id<CR><LF>	<b>in_id</b> – Indicates the ID of the input: 1-n (n= the total number of inputs) 1 – HDMI IN 1 2 – HDMI IN 2 3 – HDMI IN 3 4 – HDMI IN 4 5 – HDMI IN 5 6 – HDMI IN 6 7 – HDMI IN 7 8 – HDMI IN 8 9 – Pattern > – Connection character between in and out parameters <b>out_id</b> –Output number * for all outputs	Switch IN 1 to OUT 3: #VID_1>3<CR>
VID?	LEGACY COMMAND. Get video switch state. The GET command identifies input switching on Step-in clients. The SET command is for remote input switching on Step-in clients (essentially via by the Web). This is a legacy command. New Step-in modules support the ROUTE command.	<b>COMMAND</b> #VID?_out_id<CR> <b>FEEDBACK</b> ~nn@VID_in_id>out_id<CR><LF>	<b>in_id</b> – Indicates the ID of the input: 10 – HDMI IN 1 11 – HDMI IN 2 12 – HDMI IN 3 13 – HDMI IN 4 14 – HDMI IN 5 15 – HDMI IN 6 16 – HDMI IN 7 17 – HDMI IN 8 18 – Pattern > – Connection character between in and out parameters <b>out_id</b> –Output number: 1 – HDMI OUT 1 2 – HDMI OUT 2 3 – HDMI OUT 3 4 – HDMI OUT 4 5 – HDMI OUT 5 6 – HDMI OUT 6 7 – HDMI OUT 7 8 – HDMI OUT 8	Get video switch state: #VID?_2<CR>
VID- PATTERN	Set test pattern on output.	<b>COMMAND</b> #VID-PATTERN_out_index,pattern_id<CR> <b>FEEDBACK</b> ~nn@VID-PATTERN_out_index,pattern_id<CR><LF>	<b>out_index</b> – Number that indicates the specific output: 1 – HDMI OUT 1 2 – HDMI OUT 2 3 – HDMI OUT 3 4 – HDMI OUT 4 5 – HDMI OUT 5 6 – HDMI OUT 6 7 – HDMI OUT 7 8 – HDMI OUT 8 <b>pattern_id</b> –Number of system	Switch PATTERN 1 to OUT 3: #VID-PATTERN_3,1<CR>

Function	Description	Syntax	Parameters/Attributes	Example
			patterns: 1 – Pattern1 2 – Pattern2 3 –Pattern3 4 –Pattern4 5–Pattern5 6–Pattern6 7–Pattern7 8– Splash Screen	
VID- PATTERN?	Get test pattern on output.	<b>COMMAND</b> #VID-PATTERN?_out_index<CR> <b>FEEDBACK</b> ~nn@VID-PATTERN_out_index,pattern_id<CR><LF>	<b>out_index</b> – Number that indicates the specific output: 1– HDMI OUT 1 2– HDMI OUT 1 3– HDMI OUT 2 4– HDMI OUT 3 5– HDMI OUT 4 6– HDMI OUT 5 7– HDMI OUT 6 8– HDMI OUT 7 9– HDMI OUT 8 <b>pattern_id</b> – Number of system patterns 1 – Pattern1 2 – Pattern2 3 –Pattern3 4 –Pattern4 5–Pattern5 6–Pattern6 7–Pattern7 8–Splash Screen	Get test pattern on output: #VID-PATTERN?_3<CR>
VMUTE	Set enable/disable video on output. ⓘ Video mute parameter 2 (blank picture) is not supported.	<b>COMMAND</b> #VMUTE_out_index,flag<CR> <b>FEEDBACK</b> ~nn@VMUTE_out_index,flag<CR><LF>	<b>out_index</b> – Number that indicates the specific output: 1– HDMI OUT 1 2– HDMI OUT 2 3– HDMI OUT 3 4– HDMI OUT 4 5– HDMI OUT 5 6– HDMI OUT 6 7– HDMI OUT 7 8– HDMI OUT 8 255–All HDMI OUTPUTS <b>flag</b> – Video Mute 0 – Video enabled 1 – Video disabled 2 – Blank picture	Disable the video output on OUT 2: #VMUTE_2, 0<CR>
VMUTE?	Get video on output status. ⓘ Video mute parameter 2 (blank picture) is not supported.	<b>COMMAND</b> #VMUTE?_out_index<CR> <b>FEEDBACK</b> ~nn@VMUTE_out_index,flag<CR><LF>	<b>out_index</b> – Number that indicates the specific output: 1– HDMI OUT 1 2– HDMI OUT 2 3– HDMI OUT 3 4– HDMI OUT 4 5– HDMI OUT 5 6– HDMI OUT 6 7– HDMI OUT 7 8– HDMI OUT 8 <b>flag</b> – Video Mute 0 – Video enabled 1 – Video disabled 2 – Blank picture	Get video on output status: #VMUTE?_2<CR>
EXT-PING	Ping the IP address.	<b>COMMAND</b> #EXT-PING_ip_address<CR> <b>FEEDBACK</b> ~nn@EXT-PING_ping_information<CR><LF>	<b>ip_address</b> – Format: xxx.xxx.xxx.xxx	Get the gateway IP address: #EXT-PING 192.168.1.39<CR>
EXT-NET-MAC?	Get the MAC address	<b>COMMAND</b> #EXT-NET-MAC?_slot_id<CR> <b>FEEDBACK</b> ~nn@EXT-NET-MAC?_slot_id,mac_address<CR><LF>	<b>slot_id</b> –0	Get the MAC address for the card in slot 1: #EXT-NET-MAC? 0<CR>
LDEDID	Write EDID data from external application to device. ⓘ When the unit receives the LDEDID command it replies with READY and enters the special EDID packet wait mode. In this mode the unit can receive only	<b>COMMAND</b> Multi-step syntax <b>FEEDBACK</b> Step 1: #LDEDID_edid_io,dest_bitmask,edid_size,safe_mode<CR> Response 1: ~nn@LDEDID_edid_io,dest_bitmask,edid_size,safe_mode_ready<CR><LF>	<b>edid_io</b> – EDID destination type (usually input) 0– Input 1– Output 2– Default EDID 3– Custom EDID <b>dest_bitmask</b> – Bitmap representing destination IDs. Format: 0x*****, where * is ASCII presentation of hex digit. The binary presentation of this number is a bit mask for	Write the EDID data from an external application to the HDMI In 1 input without adjustment attempts: #LDEDID_0,0x1,2340,0<CR> Write the EDID data from an external application to HDMI In 1 and PC In inputs with adjustment attempts: #LDEDID_0,0x5,2340,1<CR>

Function	Description	Syntax	Parameters/Attributes	Example										
	<p>packets and not regular protocol commands.</p> <p>If the unit does not receive correct packets for 30 seconds or is interrupted for more than 30 seconds before receiving all packets, it sends timeout error <code>~nn@LDEDID err01 &lt;CR&gt;&lt;LF&gt;</code> and returns to the regular protocol mode. If the unit received data that is not a correct packet, it sends the corresponding error and returns to the regular protocol mode.</p>	<pre>~nn@LDEDID_errnn&lt;CR&gt;&lt;LF&gt;</pre> <p>Step 2: If ready was received, send EDID_DATA</p> <p>Response 2:</p> <pre>~nn@LDEDID_edid_io,dest_bitmask,edid_size, safe_mode_ok&lt;CR&gt;&lt;LF&gt;</pre> <p>or</p> <pre>~nn@LDEDID_errnn&lt;CR&gt;&lt;LF&gt;</pre>	<p>destinations. Setting '1' means EDID data has to be copied to this destination</p> <p><b>edid_size</b> – EDID data size</p> <p><b>safe_mode</b> – Safe mode</p> <p>0 – Device accepts the EDID as is without trying to adjust</p> <p>1 – Device tries to adjust the EDID</p> <p><b>edid_data</b> – Data in protocol packets</p> <p><b>Using the Packet Protocol</b></p> <p>Send a command: LDRV, LOAD, IROUT, LDEDID</p> <p>Receive Ready or ERR###</p> <p>If Ready:</p> <ol style="list-style-type: none"> <li>Send a packet,</li> <li>Receive OK on the last packet,</li> <li>Receive OK for the command</li> </ol> <p>Packet structure:</p> <p><b>Packet ID</b> (1, 2, 3...) (2 bytes in length)</p> <p><b>Length</b> (data length + 2 for CRC) – (2 bytes in length)</p> <p><b>Data</b> (data length -2 bytes)</p> <p><b>CRC</b> – 2 bytes</p> <table border="1"> <thead> <tr> <th>01</th> <th>02</th> <th>03</th> <th>04</th> <th>05</th> </tr> </thead> <tbody> <tr> <td>Packet ID</td> <td>Length</td> <td>Data</td> <td>CRC</td> <td></td> </tr> </tbody> </table> <p>5. Response:</p> <pre>~nnnn_ok&lt;CR&gt;&lt;LF&gt;</pre> <p>(Where <b>NNNN</b> is the received packet ID in ASCII hex digits.)</p>	01	02	03	04	05	Packet ID	Length	Data	CRC		
01	02	03	04	05										
Packet ID	Length	Data	CRC											
<b>TIME</b>	<p>Set device time and date.</p> <p><b>i</b> The year must be 4 digits.</p> <p>The device does not validate the day of week from the date.</p> <p>Time format - 24 hours. Date format - Day, Month, Year.</p>	<p><b>COMMAND</b></p> <pre>#TIME_day_of_week,date,data&lt;CR&gt;</pre> <p><b>FEEDBACK</b></p> <pre>~nn@TIME_day_of_week,date,data&lt;CR&gt;&lt;LF&gt;</pre>	<p><b>day_of_week</b> – One of {SUN,MON,TUE,WED,THU,FRI,SAT}</p> <p><b>date</b> – Format: DD-MM-YYYY.</p> <p><b>data</b> – Format: hh:mm:sswhere</p> <p>hh = hours mm = minutes ss = seconds</p>	<p>Set device time and date to December 5, 2018 at 2:30pm:</p> <pre>#TIME_mon_05-12-2018,14:30:00&lt;CR&gt;</pre>										
<b>TIME?</b>	<p>Get device time and date.</p> <p><b>i</b> The year must be 4 digits.</p> <p>The device does not validate the day of week from the date.</p> <p>Time format - 24 hours. Date format - Day, Month, Year.</p>	<p><b>COMMAND</b></p> <pre>#TIME?&lt;CR&gt;</pre> <p><b>FEEDBACK</b></p> <pre>~nn@TIME_day_of_week,date,data&lt;CR&gt;&lt;LF&gt;</pre>	<p><b>day_of_week</b> – One of {SUN,MON,TUE,WED,THU,FRI,SAT}</p> <p><b>date</b> – Format: YYYY/MM/DD where</p> <p>YYYY = Year MM = Month DD = Day</p> <p><b>data</b> – Format: hh:mm:sswhere</p> <p>hh = hours mm = minutes ss = seconds</p>	<p>Get device time and date:</p> <pre>#TIME?&lt;CR&gt;</pre>										
<b>X-SIGNAL?</b>	<p>Get input signal status.</p> <p><b>i</b> This is an Extended Protocol 3000 command.</p>	<p><b>COMMAND</b></p> <pre>#X-SIGNAL?_&lt;direction_type&gt;.&lt;port_index&gt;.&lt;index&gt;&lt;CR&gt;</pre> <p><b>FEEDBACK</b></p> <pre>~nn@X-SIGNAL_&lt;direction_type&gt;.&lt;port_index&gt;.&lt;index&gt;,status&lt;CR&gt;&lt;LF&gt;</pre>	<p>The following attributes comprise the signal ID:</p> <p><b>&lt;direction_type&gt;</b> – IN.HDMI</p> <p><b>&lt;port_index&gt;</b> – The port number as printed on the front or rear panel</p> <p><b>&lt;index&gt;</b> – 1</p> <p><b>status</b> – Input Signal Status</p> <p>0 – No signal 1 – There is a signal</p>	<p><b>#X-SIGNAL?_in.hdmi.1.video.1&lt;CR&gt;</b></p> <pre>~01@X-SIGNAL_in.hdmi.1.video.1.&lt;CR&gt;&lt;LF&gt;</pre>										
<b>ECHO</b>	<p>Set Echoing ON/OFF function.</p> <p><b>i</b> Sending commands via RS-232 port while echoing is disabled will result in no status change on UDP/TCP port</p>	<p><b>COMMAND</b></p> <pre>#ECHO_echo_state&lt;CR&gt;</pre> <p><b>FEEDBACK</b></p> <pre>~nn@ECHO_echo_state&lt;CR&gt;&lt;LF&gt;</pre>	<p><b>echo_state</b> – Enable/Disable link</p> <p>0 – disable 1 – enable</p>	<p>Set Echoing function to ON:</p> <pre>#ECHO_1&lt;CR&gt;</pre>										
<b>ECHO?</b>	<p>Get Echo state (ON/OFF).</p> <p><b>i</b> Sending commands via RS-232 port while echoing is disabled will result in no status change on UDP/TCP port</p>	<p><b>COMMAND</b></p> <pre>#ECHO?&lt;CR&gt;</pre> <p><b>FEEDBACK</b></p> <pre>~nn@AUD-CH-LINK_echo_state&lt;CR&gt;&lt;LF&gt;</pre>	<p><b>echo_state</b> – Enable/Disable link</p> <p>0 – disable 1 – enable</p>	<p>Get Echoing function state:</p> <pre>#ECHO?&lt;CR&gt;</pre>										
<b>FCT-MAC</b>	<p>Set MAC address.</p> <p><b>i</b> To activate the change, reset the device.</p>	<p><b>COMMAND</b></p> <pre>#FCT-MAC_mac_address&lt;CR&gt;</pre> <p><b>FEEDBACK</b></p> <pre>~nn@FCT-MAC_mac_address&lt;CR&gt;&lt;LF&gt;</pre>	<p><b>mac_address</b> – Unique MAC address. Format: XX-XX-XX-XX-XX-XX where X is a hex digit</p>	<p>Set MAC address:</p> <pre>#FCT-MAC_00-14-22-01-23-45&lt;CR&gt;</pre>										
<b>FCT-MODEL</b>	<p>Set model name.</p> <p><b>i</b> Used where a single firmware file is adaptable for many</p>	<p><b>COMMAND</b></p> <pre>#FCT-MODEL_model_name&lt;CR&gt;</pre>	<p><b>model_name</b> – String of printable ASCII chars (up to 19 chars)</p>	<p>Set model name:</p> <pre>#FCT-MODEL_dip-20&lt;CR&gt;</pre>										

Function	Description	Syntax	Parameters/Attributes	Example
	devices, but the user needs to know (by protocol) which specific model is used.	<b>FEEDBACK</b> ~nn@FCT-MODEL_model_name<CR><LF>		
FCT-SN	Set serial number.	<b>COMMAND</b> #FCT-SN_serial_num<CR> <b>FEEDBACK</b> ~nn@FCT-SN_serial_num<CR><LF>	serial_num – 14 decimal digits	Set serial number: #FCT-SN_19763840581123<CR>
NET-DNS?	Get DNS name server. ① There is no "Set" command. Use NET-CONFIG to set up network, including DNS name servers.  If dns_id is out of the defined DNS range, Error Code #3 (ERR_PARAMETER_OUT_OF_RANGE) is returned.  If no dns_id is defined, Error Code #3 is returned for any dns_id.	<b>COMMAND</b> #NET-DNS?_dns_id<CR> <b>FEEDBACK</b> ~nn@NET-DNS_dns_id,dns_ip<CR><LF>	dns_id – ID of the DNS name server to retrieve, indexing starts at "1" dns_ip – IP address of the DNS server	Get DNS name server: #NET-DNS?_ 1<CR>
AUD-LVL	Set volume value for port	<b>COMMAND</b> #AUD-LVL_stage,port_id,volume<CR> <b>FEEDBACK</b> ~nn@AUD-LVL_ stage,port_id,volume <CR><LF>	stage-1 port_id-output number volume-audio parameter level from 0 to 100.	Set analog audio OUT1 volume to 74. #aud-lvl 1,1,74<CR>
AUD-LVL?	Get volume value for port	<b>COMMAND</b> #AUD-LVL?_stage,port_id<CR> <b>FEEDBACK</b> ~nn@AUD-LVL_ stage,port_id,volume <CR><LF>	stage-1 port_id-output number volume-audio parameter level from 0 to 100.	Get analog audio OUT4 volume. #aud-lvl? 1,4<CR>
NET-CONFIG	Set Ethernet IP and MASK and Gateway	<b>COMMAND</b> #NET-CONFIG_id,ip,net_mask,gateway<CR> <b>FEEDBACK</b> ~nn@NET-CONFIG id,ip,net_mask,gateway<CR><LF>	id - 0, ip - network IP address; net_mask - network mask; gateway - network gateway;	Set device Ethernet IP and MASK and Gateway. #NET-CONFIG 0,192.168.20.231,255.255.255.0,192.168.20.1<CR>
NET-CONFIG?	Get Ethernet IP and MASK and Gateway	<b>COMMAND</b> #NET-CONFIG?_id<CR> <b>FEEDBACK</b> ~nn@NET-CONFIG id,ip,net_mask,gateway<CR><LF>	id - 0, ip - network IP address; net_mask - network mask; gateway - network gateway;	Get device Ethernet IP and MASK and Gateway. #NET-CONFIG? 0<CR>
MODULE-FUNC	Set Port parameter value	<b>COMMAND</b> #MODULE-FUNC para_id,stage,port_id,para_value <CR> <b>FEEDBACK</b> ~nn@MODULE-FUNC para_id,stage,port_id,para_value <CR><LF>	para_id - the ID for the functions of the port para_id=110,Input HDCP Version(para_value=0,HDCP OFF; para_value=1,HDCP 1.4; para_value=2,HDCP 2.2) para_id=102,Input ARC state(para_value=0,ARC Disable; para_value=1,ARC Enable) para_id=45,Output Resolution(para_value=0,Native; para_value=1,Passthrough; para_value=15,3840*2160*60; para_value=14,3840*2160*50; para_value=13,3840*2160*30; para_value=12,3840*2160*25; para_value=11,1920*1200*60; para_value=10,1920*1080*60; para_value=9,1920*1080*50; para_value=8,1600*1200*60; para_value=7,1280*800*60; para_value=6,1360*768*60; para_value=5,1280*1024*60; para_value=4,1280*720*60; para_value=3,1280*720*50; para_value=2,1024*768*60; para_value=1,Passthrough) para_id=8,Output HDCP(para_value=1,Follow input; para_value=2,Always on) para_id=10,Output Color Space(para_value=0,RGB444; para_value=1,YUV444) para_id=16,Output Switch mode(para_value=0,Manual; para_value=1,Priority; para_value=2,Last-Connected) para_id=17,Output Ratio(para_value=0,Full; para_value=1,Best Fit)	Set input1 HDCP Version is HDCP OFF. #MODULE-FUNC 110,0,1,0<CR>

Function	Description	Syntax	Parameters/Attributes	Example
			<p><a href="#">para_id=102</a>,Output ARC state(<a href="#">para_value=0</a>,ARC Disable; <a href="#">para_value=1</a>,ARC Enable)</p> <p><a href="#">para_id=44</a>,Output Multiview mode(<a href="#">para_value=0</a>, Multiview OFF; <a href="#">para_value=1</a>, Multiview ON)</p> <p><a href="#">para_id=40</a>,Output freeze mode(<a href="#">para_value=0</a>, freeze OFF; <a href="#">para_value=1</a>, freeze ON)</p> <p><a href="#">para_id=132</a>,Output OSD mode(<a href="#">para_value=0</a>, OSD OFF; <a href="#">para_value=1</a>, OSD ON)</p> <p><a href="#">para_id=131</a>,Output Auto –sync off mode(<a href="#">para_value=0</a>, Auto –sync off OFF; <a href="#">para_value=1</a>, Auto –sync off ON)</p> <p><a href="#">para_id=133</a>,Output Auto –sync off times(<a href="#">para_value=5-900</a>)</p> <p><a href="#">stage</a> - 0 for input port, 1 for output port;</p> <p><a href="#">port_id</a> - port number;</p> <p><a href="#">para_value</a> - the paramter's value,For specific parameters, please refer to the above.</p>	
<b>MODULE-FUNC?</b>	Set Port parameter value	<p><b>COMMAND</b></p> <p><b>#MODULE-FUNC? <a href="#">para_id,stage,port_id</a>&lt;CR&gt;</b></p> <p><b>FEEDBACK</b></p> <p>~nn@MODULE-FUNC</p> <p><a href="#">para_id,stage,port_id,para_value</a> &lt;CR&gt;&lt;LF&gt;</p>	<p><a href="#">para_id</a> - the ID for the functions of the port</p> <p><a href="#">para_id=110</a>,Input HDCP Version(<a href="#">para_value=0</a>,HDCP OFF; <a href="#">para_value=1</a>,HDCP 1.4; <a href="#">para_value=2</a>,HDCP 2.2)</p> <p><a href="#">para_id=102</a>,Input ARC state(<a href="#">para_value=0</a>,ARC Disable; <a href="#">para_value=1</a>,ARC Enable)</p> <p><a href="#">para_id=45</a>,Output Resolution(<a href="#">para_value=0</a>,Native; <a href="#">para_value=1</a>,Passthrough; <a href="#">para_value=15</a>,3840*2160*60; <a href="#">para_value=14</a>,3840*2160*50; <a href="#">para_value=13</a>,3840*2160*30; <a href="#">para_value=12</a>,3840*2160*25; <a href="#">para_value=11</a>,1920*1200*60; <a href="#">para_value=10</a>,1920*1080*60; <a href="#">para_value=9</a>,1920*1080*50; <a href="#">para_value=8</a>,1600*1200*60; <a href="#">para_value=7</a>,1280*800*60; <a href="#">para_value=6</a>,1360*768*60; <a href="#">para_value=5</a>,1280*1024*60; <a href="#">para_value=4</a>,1280*720*60; <a href="#">para_value=3</a>,1280*720*50; <a href="#">para_value=2</a>,1024*768*60; <a href="#">para_value=1</a>,Passthrough)</p> <p><a href="#">para_id=8</a>,Output HDCP(<a href="#">para_value=1</a>,Follow input; <a href="#">para_value=2</a>,Always on)</p> <p><a href="#">para_id=10</a>,Output Color Space(<a href="#">para_value=0</a>,RGB444; <a href="#">para_value=1</a>,YUV444)</p> <p><a href="#">para_id=16</a>,Output Switch mode(<a href="#">para_value=0</a>,Manual; <a href="#">para_value=1</a>,Priority; <a href="#">para_value=2</a>,Last-Connected)</p> <p><a href="#">para_id=17</a>,Output Ratio(<a href="#">para_value=0</a>,Full; <a href="#">para_value=1</a>,Best Fit)</p> <p><a href="#">para_id=102</a>,Output ARC state(<a href="#">para_value=0</a>,ARC Disable; <a href="#">para_value=1</a>,ARC Enable)</p> <p><a href="#">para_id=44</a>,Output Multiview mode(<a href="#">para_value=0</a>, Multiview OFF; <a href="#">para_value=1</a>, Multiview ON)</p> <p><a href="#">para_id=40</a>,Output freeze mode(<a href="#">para_value=0</a>, freeze OFF; <a href="#">para_value=1</a>, freeze ON)</p> <p><a href="#">para_id=132</a>,Output OSD mode(<a href="#">para_value=0</a>, OSD OFF; <a href="#">para_value=1</a>, OSD ON)</p> <p><a href="#">para_id=131</a>,Output Auto –sync off mode(<a href="#">para_value=0</a>, Auto –sync off OFF; <a href="#">para_value=1</a>, Auto –sync off ON)</p> <p><a href="#">para_id=133</a>,Output Auto –sync off times(<a href="#">para_value=5-900</a>)</p> <p><a href="#">stage</a> - 0 for input port, 1 for output port;</p> <p><a href="#">port_id</a> - port number;</p> <p><a href="#">para_value</a> - the paramter's value,For specific parameters, please refer to the above.</p>	Get Output8 switch mode. #MODULE-FUNC? <a href="#">16,1,8</a> <CR>
<b>EXT-FAN-STAT?</b>	GET the Fan Status	<p><b>COMMAND</b></p> <p><b>#EXT-FAN-STAT?&lt;CR&gt;</b></p> <p><b>FEEDBACK</b></p> <p>~nn@EXT-FAN-STAT <a href="#">stage</a>&lt;CR&gt;&lt;LF&gt;</p>	<p><a href="#">stage</a> – fan status(OK/Warn)</p>	Get the fan status. #EXT-FAN-STAT? <CR>
<b>FLAG-ME</b>	Set Flag Me. The front panel flashes for one minute.	<p><b>COMMAND</b></p> <p><b>#flag-me&lt;CR&gt;</b></p>		Set flag me mode. #flag-me<CR>

Function	Description	Syntax	Parameters/Attributes	Example
		FEEDBACK ~nn@FLAG-ME OK<CR><LF>		
HW-TEMP?	Get temperature of a specific region of the hardware	COMMAND #HW-TEMP?<CR> FEEDBACK ~nn@HW-TEMP Temperature<CR><LF>	Temperature-Current temperature value, °C	Get current temperature. #HW-TEMP? <CR>
LOG-TAIL?	Get the last <n> lines of message logs	COMMAND #LOG-TAIL? n<CR> FEEDBACK ~nn@ LOG-TAIL n READY data ~01@LOG-TAIL n OK<CR><LF>	n- the last <n> lines of message logs. data- the content of the log.	Get the last 10 lines of message logs. #LOG-TAIL? 10<CR>
PRST-CLEAR	Clear saved preset list	COMMAND #PRST-CLEAR preset<CR> FEEDBACK ~nn@PRST-CLEAR preset <CR><LF>	Preset-preset number(from 1 to 8)	Clear saved preset 3. #PRST-CLEAR 3<CR>
PRST-LABEL	Set preset label	COMMAND #PRST-LABEL preset,label<CR> FEEDBACK ~nn@ PRST-LABEL preset,label <CR><LF>	Preset-preset number(from 1 to 8) label-label string(Maximum 15 characters)	Set preset4 label. #PRST-LABEL 4,KHDGTUE<CR>
PRST-LABEL?	Get preset label	COMMAND #PRST-LABEL? preset<CR> FEEDBACK ~nn@ PRST-LABEL preset,label <CR><LF>	Preset-preset number(from 1 to 8) label-label string	Get preset8 label. #PRST-LABEL? 8<CR>
STANDBY	Set Standby status	COMMAND #STANDBY stage,time<CR> FEEDBACK ~nn@STANDBY stage,time <CR><LF>	Stage-standby mode (1-on/0-off) Time-standby time (from 1 to 60min)	Set standby mode on and standby time is 12min. #standby 1,12<CR>
STANDBY?	Get Standby status	COMMAND #STANDBY?<CR> FEEDBACK ~nn@STANDBY stage,time<CR><LF>	Stage-standby mode (1-on/0-off) Time-standby time (from 1 to 60min)	Get Standby status. #standby? <CR>
X-LABEL	Set the title of port	COMMAND #X-LABEL port_id,label<CR> FEEDBACK ~nn@X-LABEL port_id,label<CR><LF>	port_id-OUT/IN.HDMI/ANALOG_AUDIO.port id label-label string(Maximum 15 characters)	Set HDMI OUT1 label. #X-label OUT.HDMI.1,BHJUDG<CR>
X-LABEL?	Get the title of port	COMMAND #X-LABEL? port_id<CR> FEEDBACK ~nn@X-LABEL port_id,label<CR><LF>	port_id-OUT/IN.HDMI/ANALOG_AUDIO.port id label-label string	Get Analog audio IN1 label. #X-label? IN.ANALOG_AUDIO.1<CR>
VFRZ	Set output Video Freeze Status	COMMAND #VFRZ port_id,freeze_flag<CR> FEEDBACK ~nn@VFRZ port_id,freeze_flag <CR><LF>	port_id-port number freeze_flag-ON/OFF	Set OUT1 video freeze ON. #VFRZ 1,ON<CR>
VFRZ?	Get output Video Freeze Status	COMMAND #VFRZ? port_id<CR> FEEDBACK ~nn@VFRZ port_id,freeze_flag <CR><LF>	port_id-port number freeze_flag-ON/OFF	Get OUT7 video freeze status. #VFRZ? 7<CR>
VID-RES	Set port resolution	COMMAND #VID-RES stage,port_id,is_native,resolution id<CR> FEEDBACK ~nn@ VID-RES stage,port_id,is_native,resolution id <CR><LF>	stage-1 port_id-port number is_native-0=OFF,1=ON resolution id-1=Passthrough; 15=3840*2160*60 14=3840*2160*50 13=3840*2160*30 12=3840*2160*25 11=1920*1200*60 10=1920*1080*60 9=1920*1080*50 8=1600*1200*60 7=1280*800*60 6=1360*768*60 5=1280*1024*60 4=1280*720*60 3=1280*720*50 2=1024*768*60	Set OUT1 resolution is 3840*2160*60. #VID-RES 1,1,0,15<CR>  Set OUT2 resolution is Native. #VID-RES 1,2,1,1<CR>
VID-RES?	Get port resolution	COMMAND #VID-RES? stage,port_id,is_native<CR> FEEDBACK ~nn@ VID-RES stage,port_id,is_native,resolution id <CR><LF>	stage-1 port_id-port number is_native-0=OFF resolution id-0=Native 1=Passthrough; 15=3840*2160*60 14=3840*2160*50	Get OUT6 resolution. #VID-RES? 1,6,0<CR>

Function	Description	Syntax	Parameters/Attributes	Example
			13=3840*2160*30 12=3840*2160*25 11=1920*1200*60 10=1920*1080*60 9=1920*1080*50 8=1600*1200*60 7=1280*800*60 6=1360*768*60 5=1280*1024*60 4=1280*720*60 3=1280*720*50 2=1024*768*60	

## Result and Error Codes

### Syntax

In case of an error, the device responds with an error message. The error message syntax:

- **~NN@ERR XXX<CR><LF>** – when general error, no specific command
- **~NN@CMD ERR XXX<CR><LF>** – for specific command
- **NN** – machine number of device, default = 01
- **XXX** – error code

### Error Codes

Error Name	Error Code	Description
P3K_NO_ERROR	0	No error
ERR_PROTOCOL_SYNTAX	1	Protocol syntax
ERR_COMMAND_NOT_AVAILABLE	2	Command not available
ERR_PARAMETER_OUT_OF_RANGE	3	Parameter out of range
ERR_UNAUTHORIZED_ACCESS	4	Unauthorized access
ERR_INTERNAL_FW_ERROR	5	Internal FW error
ERR_BUSY	6	Protocol busy
ERR_WRONG_CRC	7	Wrong CRC
ERR_TIMEDOUT	8	Timeout
ERR_RESERVED	9	(Reserved)
ERR_FW_NOT_ENOUGH_SPACE	10	Not enough space for data (firmware, FPGA...)
ERR_FS_NOT_ENOUGH_SPACE	11	Not enough space – file system
ERR_FS_FILE_NOT_EXISTS	12	File does not exist
ERR_FS_FILE_CANT_CREATED	13	File can't be created
ERR_FS_FILE_CANT_OPEN	14	File can't open
ERR_FEATURE_NOT_SUPPORTED	15	Feature is not supported
ERR_RESERVED_2	16	(Reserved)
ERR_RESERVED_3	17	(Reserved)
ERR_RESERVED_4	18	(Reserved)
ERR_RESERVED_5	19	(Reserved)
ERR_RESERVED_6	20	(Reserved)
ERR_PACKET_CRC	21	Packet CRC error
ERR_PACKET_MISSED	22	Packet number isn't expected (missing packet)
ERR_PACKET_SIZE	23	Packet size is wrong
ERR_RESERVED_7	24	(Reserved)
ERR_RESERVED_8	25	(Reserved)
ERR_RESERVED_9	26	(Reserved)
ERR_RESERVED_10	27	(Reserved)
ERR_RESERVED_11	28	(Reserved)
ERR_RESERVED_12	29	(Reserved)
ERR_EDID_CORRUPTED	30	EDID corrupted
ERR_NON_LISTED	31	Device specific errors
ERR_SAME_CRC	32	File has the same CRC – no changed
ERR_WRONG_MODE	33	Wrong operation mode
ERR_NOT_CONFIGURED	34	Device/chip was not initialized



**HDMI™**  
HIGH-DEFINITION MULTIMEDIA INTERFACE



P/N:



2900-301853

Rev:



2



#### SAFETY WARNING

Disconnect the unit from the power supply before opening and servicing

For the latest information on our products and a list of Kramer distributors, visit our website where updates to this user manual may be found.

We welcome your questions, comments, and feedback.

The terms HDMI, HDMI High-Definition Multimedia Interface, and the HDMI Logo are trademarks or registered trademarks of HDMI Licensing Administrator, Inc. All brand names, product names, and trademarks are the property of their respective owners.