



E-GD-MBP

Gas Detector

Installation and Operation Instructions

Description

The E-GD-MBP Gas Detector will detect and provide early warning of the presence of combustible gas (Natural Gas, Methane, Propane, Butane, etc) at varying percentages of LEL (Lower Explosion Limit- the lowest concentration (percentage) of gas or vapor in air capable of producing a flash fire in the presence of an ignition source (arc, flame, heat))* depending upon the type of gas being sensed. The E-GD-MBP will provide warnings when used in conjunction with the E-16D,E-5D, E-2D or E-MINI-LXO Enterprise Environment Monitoring Systems (SYSTEM). By providing an effective early warning of potentially dangerous leaks, the E-GD-MBP Gas Detector can help prevent loss of life and damage to property.

Features:

- Use to detect leaks of combustible gas (Natural gas, Methane, Propane, Butane, Acetylene, etc) with two levels of detection:
 - First Level:
 - Detects methane at concentrations in excess of 0.5%
 - Detects propane/butane at concentrations in excess of 0.3%
 - Second Level:
 - Detects methane at concentrations in excess of 0.8%.
 - Detects propane/iso-butane at concentrations in excess of 0.5%.
- Continuous air monitoring
- Audible alarm signal — piezo buzzer; 94 db at 1 foot
- Relay specifications: level selectable, normally open or normally closed, 250VAC, max 5A
- Powered by E-2D/5D/16D.
- Regulatory approvals: CE

Installation:

1. Attach the detector to the wall. For gases lighter than air (natural gas, city gas etc.) install it close to the ceiling (max 15 cm or 5.9 inches beneath it) or directly on the ceiling and on the place expected to have gas leakage. For gases heavier than air (propane, butane, etc.) install it close to the floor or on the lowest place of the room. The detector should not be located close to any obstacles preventing natural air circulation.
2. Wire detector as shown in the diagrams provided.
3. Configure ENVIROMUX SYSTEM such that sensor's Normal Status is "OPEN" sending an alert when the status is "CLOSED".

Test:

To test the detector, direct the gas from a gas source (**cigarette lighter without a flame**) towards the detector. The state should change to CLOSED and the ENVIROMUX SYSTEM should send an alert within 20 seconds. Remove the gas and the detector should return to a normal "OPEN" state.

Schematic for wiring Gas Detector to ENVIROMUX SYSTEM

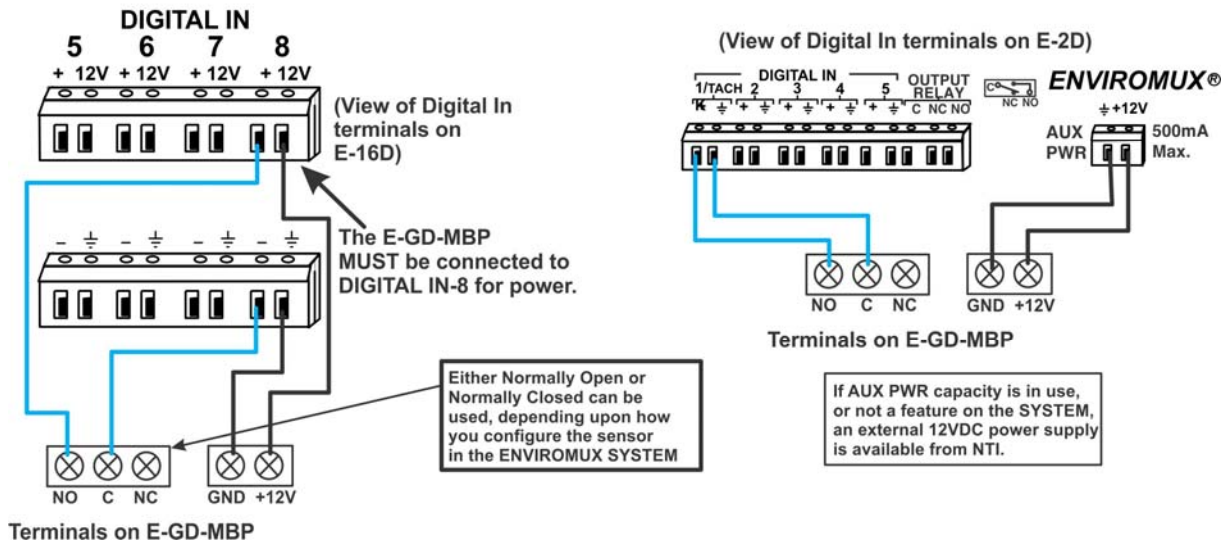

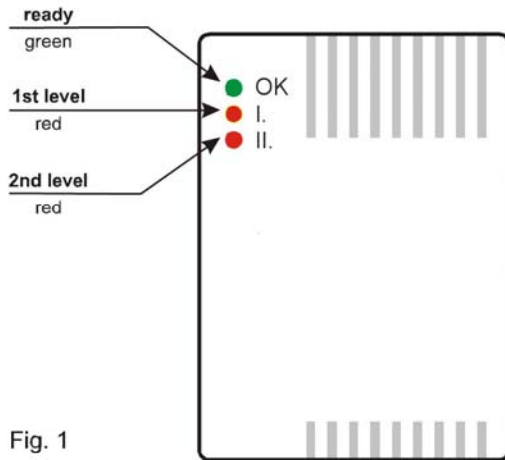

Fig. 1

Output relay function

There is a dry relay contact available on the sensor output terminals:

- C** - common contact
- NO** - normally open contact
- NC** - normally closed contact

This relay output can be used for an automatic gas valve closer, alarm system triggering or for other warning systems.

If the **REL jumper** is open, the relay will be triggered after the 1st level of gas concentration is detected. If the REL jumper is closed, the relay will be triggered after the 2nd level of gas concentration is detected.

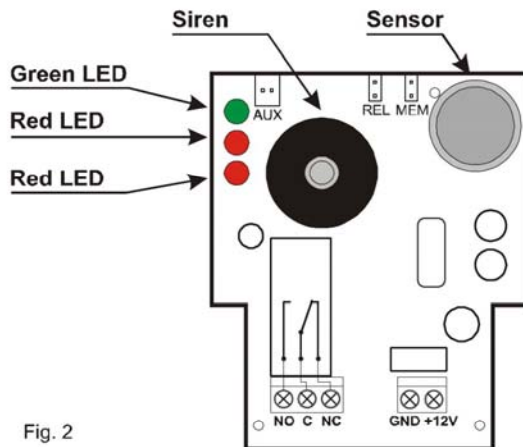

Fig. 2

Function

After switching the power on the green LED will flash for 60 sec. (the detector warms up). When the green indicator lights permanently the detector is ready.

If the gas concentration reaches the 1st level, short beeps will sound and red LED I will go off.

If the gas concentration reaches the 2nd level, long beeps will sound and red LED II will go off.

The output relay reacts depending on the REL jumper setting.

LED indicators		
Green	<ul style="list-style-type: none"> • OFF • Flashes • ON 	The detector is off Warming up Ready for gas alarm
Red I.	<ul style="list-style-type: none"> • ON 	1 st level of the gas concentration
Red II.	<ul style="list-style-type: none"> • ON 	2 nd level of the gas concentration
Red II.	<ul style="list-style-type: none"> • Alternating flashes 	Error in the sensor

Warning - in the case of a gas alarm stay calm and act as follows: - do not operate any switches

- do not use any kind of phone in the location of the gas leakage
- open any windows
- stop the gas leakage if possible or leave the place and call the gas supply company

Memory

The memory function is disabled by factory default (when the concentration of the gas drops down to normal, the sensor will stop the alarm signal).

Close the MEM jumper to select the memory function. Then the alarm indication, if triggered, will not stop unless the sensor power supply is terminated for a while.

Maintenance

Keep the detector clean, it is important that its grids should not be blocked with dust.

Professional recalibration of the detector should be done at least once a year. Contact your distributor for more details.

Specification:

Sensitivity:

	Methane	Propane
Level 1	10±3% LEL (0.50% vol. conc.)	18±3% LEL (0.30% vol. conc.)
Level 2	18±3% LEL (0.80% vol. conc.)	30±3% LEL (0.50% vol. conc.)

	Iso-butane
Level 1	23±3% LEL (0.30% vol. conc.)
Level 2	40±3% LEL (0.50% vol. conc.)

LEL = Lower Explosive Limit (100 %) according to EN 60079-20-1: for **methane** 4,4 % vol. conc., for **propane** 1,7 % vol. conc., for **iso-butane** 1,3 % vol. conc., calibrated by iso-butane

Power supply 12V DC ± 20%
Power consumption 100 mA
(150mA when relay is activated)

Detection method hot platinum filament
Buzzer sound level 94dB/0.3m

Relay output optional for 1st or 2nd level, max. 230V AC/5A

Alarm memory selectable

Response time 20 s

Warm up time approximately 90 s

Working environment indoor use, -10 to +40°C, IP30

Complies with

EN 50194-1, EN 60079-29-1, EN 50130-4, EN 55022

For non-explosive areas. Zone 2 according to EN 60079-10.

Certified by VVUÚ corp., certificated body No. 3076



Complies with the essential requirements of: EMC Directive 2004/108/EC concerning electromagnetic compatibility when used for its intended purpose.