



Zenty | Professional A/V Solution Provider

User Manual^[v1.0]



IP400 AV over IP System

ZT-332 | ZT-IP400(Encoder)

ZT-333 | ZT-IP400(Decoder)



ZENTY®
9807 EMILY LANE
STAFFORD, TX 77477
(844) 200-1945
SUPPORT@ZENTY.COM

Important Safety Instructions



1. Do not expose this apparatus to rain, moisture, dripping or splashing and that no objects filled with liquids, such as vases, shall be placed on the apparatus.



6. Clean this apparatus only with dry cloth.



2. Do not install or place this unit in a bookcase, built-in cabinet or in another confined space. Ensure the unit is well ventilated.



7. Unplug this apparatus during lightning storms or when unused for long periods of time.



3. To prevent risk of electric shock or fire hazard due to overheating, do not obstruct the unit's ventilation openings with newspapers, tablecloths, curtains, and similar items.



8. Protect the power cord from being walked on or pinched particularly at plugs.



4. Do not install near any heat sources such as radiators, heat registers, stoves, or other apparatus (including amplifiers) that produce heat.



9. Only use attachments / accessories specified by the manufacturer.



5. Do not place sources of naked flames, such as lighted candles, on the unit.



10. Refer all servicing to qualified service personnel.

Table of Contents

| | |
|---|----|
| 1. Introduction | 4 |
| a. Overview | 4 |
| b. Features | 4 |
| c. Package Contents | 6 |
| i. Encoder | 6 |
| ii. Decoder | 6 |
| d. Specifications | 7 |
| i. Encoder | 8 |
| ii. Decoder | 9 |
| e. Panel Description | 11 |
| i. Encoder | 11 |
| ii. Decoder | 13 |
| 2. Bracket Installation | 15 |
| 3. Typical Application | 16 |
| a. Scenario 1 | 16 |
| b. Scenario 2 | 17 |
| 4. Hardware Installation | 18 |
| 5. Operating the Devices | 19 |
| a. Introduction to Different Operation Tools | 19 |
| b. Performing Fast Switching | 20 |
| i. Before You Start | 20 |
| 6. Configuring Mouse Roaming | 23 |
| 7. Configuring before HDR10/Dolby Vision Signal Input | 26 |
| 8. Firmware Upgrade | 27 |
| 9. Maintenance | 28 |
| 10. Warranty | 28 |
| 11. Mail-In Service | 28 |
| 12. Limited Warranty Limits and Exclusions | 28 |

1. Introduction

a. Overview

IP400 series encoders and decoders provide a flexible, powerful, and scalable solution at resolutions up to 3840 x 2160@60Hz 4:4:4. They allow 4k UHD media to be switched and distributed over standard gigabit Ethernet networks, providing complete end-to-end streaming systems. Audio, video together with IR, and USB signals can be routed separately or as a whole throughout the matrix system. Encoders can be used with decoders to function a video wall up to dimensions of 16 x 16. Both of them have the capacity to handle and output up to 7.1 audio channel, allowing you to enjoy the finest sounds.

HDCP 2.2/2.3 specifications are employed. A local area network is covered with a range up to 330ft (100m) over a single Cat 5e cable or above. Standard features like, bi-directional serial, bi-directional IR, and independent analog audio input/output are included. The codecs allow roaming/USB extension to take place to control keyboard and mouse. Flexible control options are offered -- Windows PC configurator (Z-Net Configuration Tool), Z-Net on iPad and IP controller (ZT-IP100C). They are the perfect solution for any low latency and signal routing applications. Common applications include home, classrooms, conference rooms, and broadcasts.

b. Features

- Selects between either the 1G Optical port or 1G BASE-T port automatically for stable IP stream transmission.
- Distributes and switches 4k UHD AV signals via standard gigabit Ethernet networks, providing complete end-to-end streaming systems
- Supports HDMI input and output resolutions up to 3840 X 2160@60Hz 4:4:4.
- Supports streaming resolutions up to 3840 x 2160@60Hz 4:4:4.
- Features video wall up to dimensions of 16 x 16.
- Supports HDR10 and Dolby Vision.
- Supports CEC one-touch-play and standby commands to power on and off the displays, as well as CEC Frame.
- Supports Multi-Channel audio up to PCM 7.1, Dolby Atmos, DTS HD Master and DTS:X.
- Analog audio embedding and de-embedding.
- S/PDIF audio return from decoder to encoder.
- HDMI ARC audio return (FW Will be ready for Q2E)
- HDCP 2.2/2.3 compliant.

- Flexible routing policies, allowing audio, video, USB, IR, and RS232 signals to be routed separately or as a whole throughout the matrix system.
- Allows AV, USB, IR, RS232 and power signals to be delivered up to 328ft/100m over a single Cat 5e cable or above.
- 1 frame latency.
- Supports bi-directional serial communication, allowing control of remote RS232 devices between encoders/decoders and IP controller (ZT-IP100C), or between encoders.
- Supports bi-directional IR pass-through, allowing control of remote sources and display devices between encoders and decoders.
- Supports IR generation - send IR codes through API.
- USB Device ports for KM over IP seamless switching and roaming.
- Supports point-to-point, point-to-multipoint, multipoint-to-point, multipoint-to-multipoint applications.
- Supports PoE to be remotely powered by compatible power source equipment such as PoE-enabled Ethernet switch, eliminating the need for a nearby power outlet.
- Supports user-selectable output HDCP configuration via PC configurator or IP controller(ZT-IP100C).
- Fit in / Stretch out video wall, and rotate video management -- Decoded video can fill a video wall, maintain aspect ratio in a video wall, or can be rotated 180° and 270° clockwise, presenting imagery that meets customer expectations.
- Supports DHCP by default, and will fall back to Auto IP if there's no DHCP server in the system.
- Flexible control options -- Z-Net app on iPad and IP controller(ZT-IP100C).
- Supports communications protocols of Telnet, SSH, HTTP, HTTPS.

c. Package Contents

i. Encoder

- 1 x Encoder
- 1 x DC 12V Power Adapter with US Pins
- 1 x 3.5mm 3-Pin Phoenix Male Connector
- 1 x IR Emitter (1.2m)
- 1 x Broadband IR Receiver (1m, 30kHz ~ 50 kHz)
- 4 x Mounting Brackets (with 4 x M3*L5 Screws)

ii. Decoder

- 1 x Decoder
- 1 x DC 12V Power Adapter with US Pins
- 1 x 3.5mm 3-Pin Phoenix Male Connector
- 1 x IR Emitter (1.2m)
- 1 x Broadband IR Receiver (1m, 30kHz ~ 50 kHz)
- 4 x Mounting Brackets (with 4 x M3*L5 Screws)

d. Specifications

i. Encoder

| Video | |
|----------------------------|---|
| Input Video Port | 1 x female HDMI type A (19 pins) |
| Input Video Type | HDMI 2.0, HDCP 2.2/2.3 |
| Input Resolutions | <p>3840 x 2160p@24Hz 4:4:4, 3840 x 2160p@30Hz 4:4:4, 3840 x 2160p@50Hz 4:4:4, 3840 x 2160p@60Hz 4:4:4, 640 x 480p@60Hz, 720 x 480p@60Hz 1280 x 720p@60Hz, 1920 x 1080i@60Hz, 1920 x 1080p@60Hz, 720 x 576p@50Hz 1280 x 720p@50Hz, 1920 x 1080i@50Hz 1920 x 1080p@50Hz, 1920 x 1080p@24Hz 1920 x 1080p@25Hz, 640 x 480@60Hz, 800 x 600@60Hz</p> <p>1024 x 768@60Hz, 1280 x 720@60Hz 1280 x 768@60Hz, 1280 x 800@60Hz 1280 x 960@60Hz, 1280 x 1024@60Hz 1360 x 768@60Hz, 1366 x 768@60Hz 1400 x 1050@60Hz, 1440 x 900@60Hz 1600 x 900@60Hz, 1600 x 1200@60Hz 1680 x 1050@60Hz, 1920 x 1080@60Hz 1920 x 1200@60Hz</p> |
| Output Video Port | 1 x female RJ-45, 1 x Optical |
| Output Video Type | IP Stream |
| Output Resolutions | Up to 3840 x 2160p@60Hz 4:4:4 |
| Average Encoding Data Rate | 3840 x 2160@60Hz: 650Mbps (avg) / 900Mbps (max) |
| End-to-End Time Latency | 1 frame |
| Input/Output Video Signal | 0.5~1.2 V p-p |
| Input/Output DDC Signal | 5 V p-p (TTL) |
| Video Impedance | 100 Ω |
| Maximum Data Rate | 18 Gbps (6 Gbps per color) |
| Maximum Pixel Clock | 600 MHz |

| Audio | |
|---------------------|--|
| Input Audio Port | 1 x HDMI; 1 x 3.5 mm stereo jack |
| Input Audio Signal | <ul style="list-style-type: none"> HDMI: Fully supports audio formats in HDMI 2.0 specification, including PCM 2.0/5.1/7.1, Dolby TrueHD, Dolby Atmos, DTS-HD Master Audio and DTS:X; Audio In: analog |
| Output Audio Port | 1 x 3.5 mm stereo jack; 1 x S/PDIF Out; 1 x LAN/Optical |
| Output Audio Signal | <ul style="list-style-type: none"> Audio Out: analog S/PDIF Out: digital audio LAN/Optical: Fully supports audio formats in HDMI 2.0 specification, including PCM 2.0/5.1/7.1, Dolby TrueHD, Dolby Atmos, DTS-HD Master Audio and DTS:X |

| Control | |
|----------------|--|
| Control Method | Windows PC configurator (Z-Net Configuration Tool), Z-Net on iPad, IP controller (ZT-IP100C) |

| General | |
|------------------------------------|--|
| Operating Temperature/ Humidity | +32°F ~ +113°F (0°C ~ +45°C) 10% ~ 90%, non-condensing |
| Storage Temperature/ Humidity | -4°F ~ +158°F (-20°C ~ +70°C) 10% ~ 90%, non-condensing |
| Power | 12 VDC 2 A; PoE |
| Power Consumption | 7W (Max) |
| ESD Protection | Human body model: <ul style="list-style-type: none"> ±8 kV (air-gap discharge) ±4 kV (contact discharge) |
| Dimensions (W x H x D) | 8.46" x 0.98" x 4.72" (215 mm x 25 mm x 120 mm) |
| Net Weight | 1.63 lbs (0.74 kg) |

ii. Decoder

| Video | |
|----------------------------|---|
| Input Video Port | 1 x female RJ-45, 1 x Optical |
| Input Video Type | IP Stream |
| Input Resolutions | <p>3840 x 2160p@24Hz 4:4:4, 3840 x 2160p@30Hz 4:4:4, 3840 x 2160p@50Hz 4:4:4, 3840 x 2160p@60Hz 4:4:4, 640 x 480p@60Hz, 720 x 480p@60Hz 1280 x 720p@60Hz, 1920 x 1080i@60Hz, 1920 x 1080p@60Hz, 720 x 576p@50Hz 1280 x 720p@50Hz, 1920 x 1080i@50Hz 1920 x 1080p@50Hz, 1920 x 1080p@24Hz 1920 x 1080p@25Hz, 640 x 480@60Hz, 800 x 600@60Hz</p> <p>1024 x 768@60Hz, 1280 x 720@60Hz 1280 x 768@60Hz, 1280 x 800@60Hz 1280 x 960@60Hz, 1280 x 1024@60Hz 1360 x 768@60Hz, 1366 x 768@60Hz 1400 x 1050@60Hz, 1440 x 900@60Hz 1600 x 900@60Hz, 1600 x 1200@60Hz 1680 x 1050@60Hz, 1920 x 1080@60Hz 1920 x 1200@60Hz</p> |
| Output Video Port | 1 x female HDMI type A (19 pins) |
| Output Video Type | HDMI 2.0, HDCP 2.2/2.3 |
| Output Resolutions | Up to 3840 x 2160p@60Hz 4:4:4 |
| Average Encoding Data Rate | 3840 x 2160@60Hz: 650Mbps (avg) / 900Mbps (max) |
| End-to-End Time Latency | 1 frame |
| Input/Output Video Signal | 0.5~1.2 V p-p |
| Input/Output DDC Signal | 5 V p-p (TTL) |
| Video Impedence | 100 Ω |
| Maximum Data Rate | 18 Gbps (6 Gbps per color) |
| Maximum Pixel Clock | 600 MHz |

| Audio | |
|--------------------|--|
| Input Audio Port | 1 x S/PDIF IN; 1 x LAN/Optical |
| Input Audio Signal | <ul style="list-style-type: none"> • S/PDIF In: digital audio • LAN/Optical: Fully supports audio formats in HDMI 2.0 specification, including PCM 2.0/5.1/7.1, Dolby TrueHD, Dolby Atmos, DTS-HD Master Audio and DTS:X |
| Output Audio Port | 1 x HDMI; 1 x 3.5 mm stereo jack |

| Audio | |
|---------------------|---|
| Output Audio Signal | <ul style="list-style-type: none"> • HDMI: Fully supports audio formats in HDMI 2.0 specification, including PCM 2.0/5.1/7.1, Dolby TrueHD, Dolby Atmos, DTS-HD Master Audio and DTS:X; • Audio Out: Analog |

| Control | |
|----------------|---|
| Control Method | Windows PC configurator (Z-Net Configuration Tool), Z-Net on iPad, IP controller (ZT-IP100C) |

| General | |
|------------------------------------|--|
| Operating Temperature/ Humidity | +32°F ~ +113°F (0°C ~ +45°C) 10% ~ 90%, non-condensing |
| Storage Temperature/ Humidity | -4°F ~ +158°F (-20°C ~ +70°C) 10% ~ 90%, non-condensing |
| Power | 12 VDC 2 A; PoE+ |
| Power Consumption | 8.5W (Max) |
| ESD Protection | Human body model: <ul style="list-style-type: none"> • ±8 kV (air-gap discharge) • ±4 kV (contact discharge) |
| Dimensions (W x H x D) | 8.46" x 0.98" x 4.72" (215 mm x 25 mm x 120 mm) |
| Net Weight | 1.63 lbs (0.74 kg) |

e. Panel Description

i. Encoder

Front Panel



| No. | Name | Description | |
|-----|------------|-------------|--|
| 1 | POWER LED | On | The device is powered on. |
| | | Blinking | The device is booting. |
| | | Off | The device is powered off. |
| 2 | STATUS LED | Solid On | The device is connected to an active video source. |
| | | Blinking | The device is not connected to an active video source. |
| | | Off | <ul style="list-style-type: none"> The device is powered off. The device is booting. Network is down. |

Rear Panel

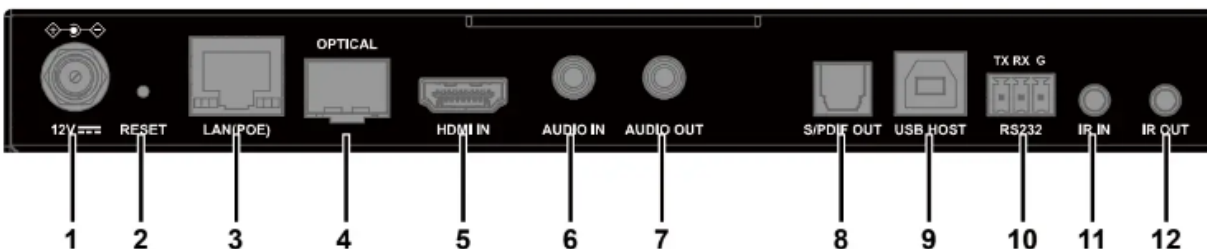

| No. | Name | Description |
|-----|-------|--|
| 1 | 12V | Connect this port to the 12 V 2 A power adapter. |
| 2 | RESET | <p>When the device is powered on, use a pointed stylus to hold down the RESET button for five or more seconds, and then release it, it will reboot and restore to its factory defaults.</p> <p>Note: When the settings are restored, your</p> |

| No. | Name | Description |
|-----|------------|---|
| | | custom data is lost. Therefore, exercise caution when using the RESET button. |
| 3 | LAN (POE) | Connect either the LAN (POE) port or Optical port to a gigabit Ethernet switch for IP stream output and device control (the device can be powered by a PoE-enabled switch through LAN (POE) port). Default IP Mode: DHCP |
| 4 | OPTICAL | <p>Note:</p> <ol style="list-style-type: none"> 1) Connect the Optical port to the Ethernet switch using a single-mode or multi-mode SFP module (not included in package). The transmission distance may vary depending on the specific SFP module used. 2) DO NOT connect both the LAN (POE) port and Optical port to the Ethernet switch simultaneously, or device exceptions may occur. |
| 5 | HDMI IN | Connect this port to an HDMI source device. |
| 6 | AUDIO IN | Connect this 3.5 mm stereo tip-ring-sleeve port to an audio source such as a computer for unbalanced stereo audio input. |
| 7 | AUDIO OUT | Connect this 3.5 mm stereo tip-ring-sleeve port to an audio receiver for unbalanced stereo audio output. |
| 8 | S/PDIF OUT | Connect this optical S/PDIF connector for digital audio output. |
| 9 | USB Host | Connect a type A male to type B male USB cable between this port and the USB port of a computer for transmitting USB 2.0 data, or for KMoIP seamless switching and roaming. |
| 10 | RS-232 | RS232 serial port for bidirectional serial communication. |
| 11 | IR IN | Connect this port to an IR receiver for IR communication with an IR emitter at the decoder side on the network. |
| 12 | IR OUT | Connect this port to an IR emitter for IR communication with an IR receiver at the decoder side on the network. |

ii. Decoder

Front Panel

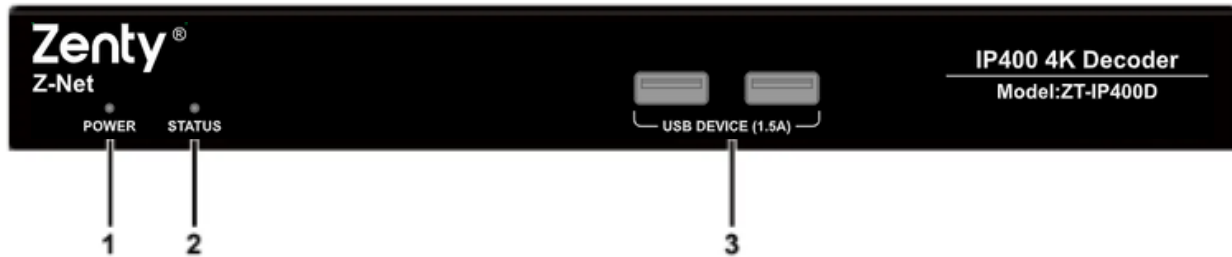

| No. | Name | Description | |
|-----|-------------------|---|--|
| 1 | POWER LED | On | The device is powered on. |
| | | Blinking | The device is booting. |
| | | Off | The device is powered off. |
| 2 | STATUS LED | Solid On | The device is connected to an encoder and the video is displayed. |
| | | Blinking | The device is not connected to an encoder or the connected encoder has no active video source input. |
| | | Off | <ul style="list-style-type: none"> • The device is powered off. • The device is booting. • Network is down. |
| 3 | USB DEVICE (1.5A) | Connect to USB devices for KMoIP seamless switching and roaming (e.g. keyboard, mouse, USB camera, USB speaker, USB microphone, USB storage device, USB touch panel, etc.). Each of the ports is able to output DC 5V 1.5A power. | |

Rear Panel

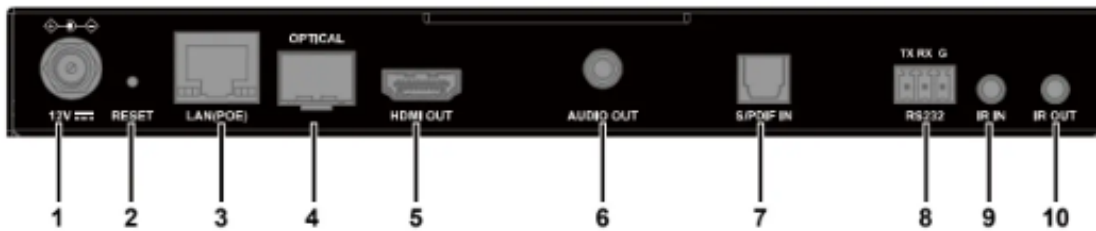

| No. | Name | Description |
|-----|-----------|--|
| 1 | 12V | Connect this port to the 12 V 2 A power adapter. |
| 2 | RESET | When the device is powered on, use a pointed stylus to hold down the RESET button for five or more seconds, and then release it, it will reboot and restore to its factory defaults. Note: When the settings are restored, your custom data is lost. Therefore, exercise caution when using the RESET button. |
| 3 | LAN (POE) | Connect either the LAN (POE) port or Optical port to a gigabit Ethernet switch for IP stream output and device control (the device can be powered by a PoE-enabled switch through LAN (POE) port). Default IP Mode: DHCP Note: 1) Connect the Optical port to the Ethernet switch using a single-mode or multi-mode SFP module (not included in package). The transmission distance may vary depending on the specific SFP module used. 2) DO NOT connect both the LAN (POE) port and the Optical port to the Ethernet switch simultaneously, or device exceptions may occur. |
| 4 | Optical | |
| 5 | HDMI OUT | Connect this port to an HDMI display device. |
| 6 | AUDIO OUT | Connect this 3.5 mm stereo tip-ring-sleeve port to an audio receiver for unbalanced stereo audio output. |
| 7 | S/PDIF IN | Optical S/PDIF connector for digital audio input (for S/PDIF audio return from decoder to encoder). |
| 8 | RS232 | RS232 serial port for bidirectional serial communication. |
| 9 | IR IN | Connect this port to an IR receiver for IR communication with an IR emitter at the decoder side on the network. |

| No. | Name | Description |
|-----|--------|---|
| 10 | IR OUT | Connect this port to an IR emitter for IR communication with an IR receiver at the decoder side on the network. |

2. Bracket Installation

Both the encoders and decoders come with mounting ears for wall mount and rack mount.

NOTE: Before installation, ensure all devices are disconnected from the power source.

Steps to install the device on a suitable location:

1. Attach the mounting brackets to the panels of both sides using the screws (two on each side) provided in the package.

Wall Mount

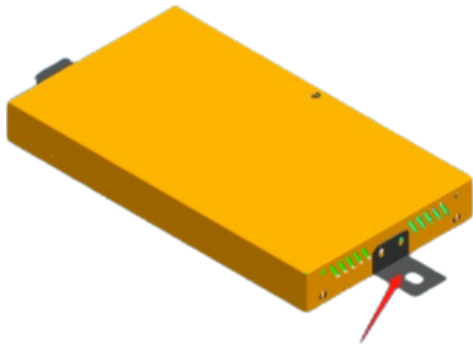

Rack Mount

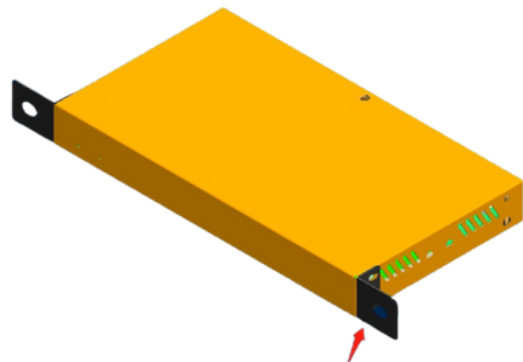

2. Install the brackets onto the position as desired using the screws (not included).

NOTE: The installation of encoders and decoders are similar. Compatible mounting bars (ZT-RM-100B) are available (sold separately) as shown below.



Model

ZT-RM-100B

3. Typical Application

a. Scenario 1

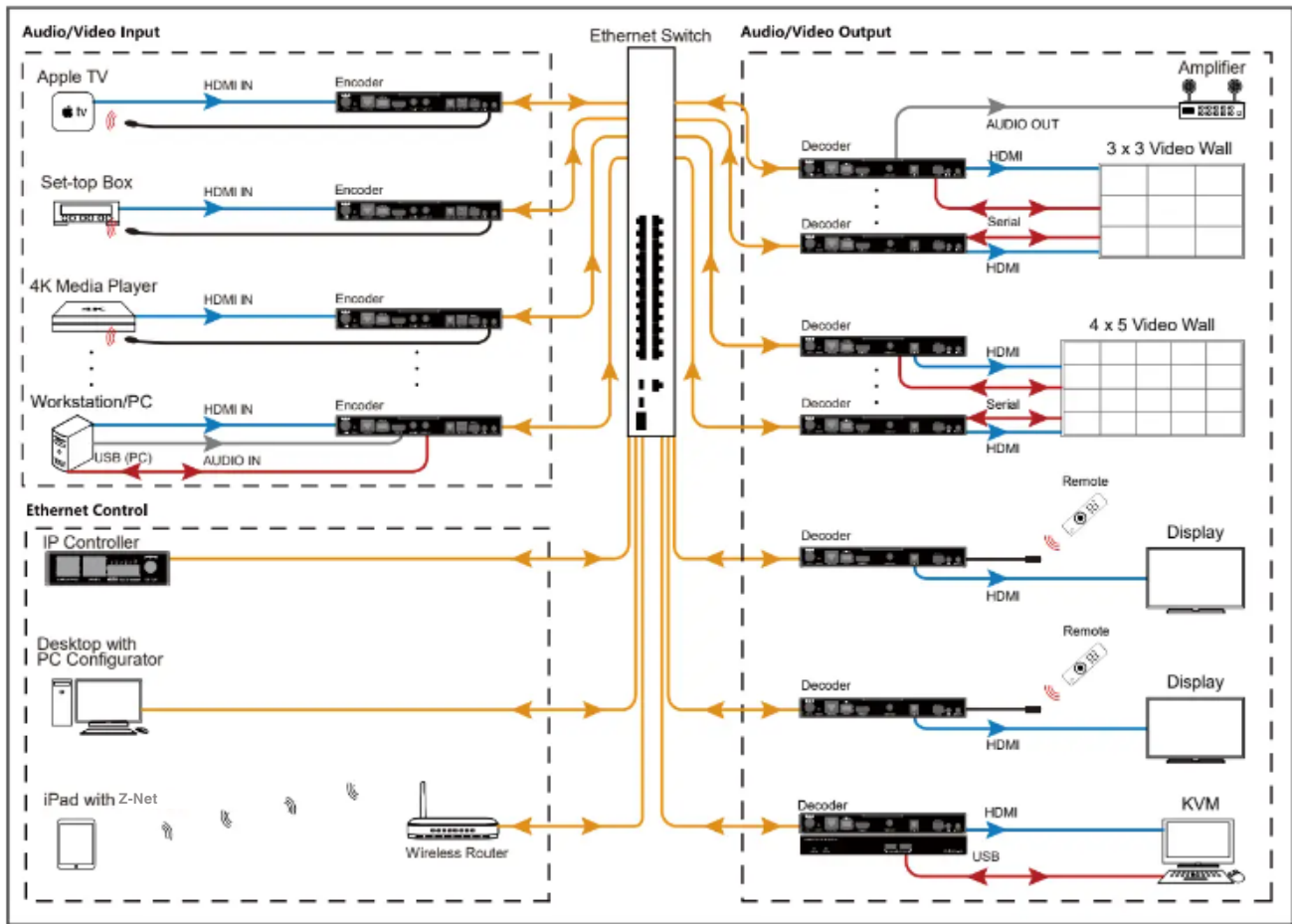

b. Scenario 2

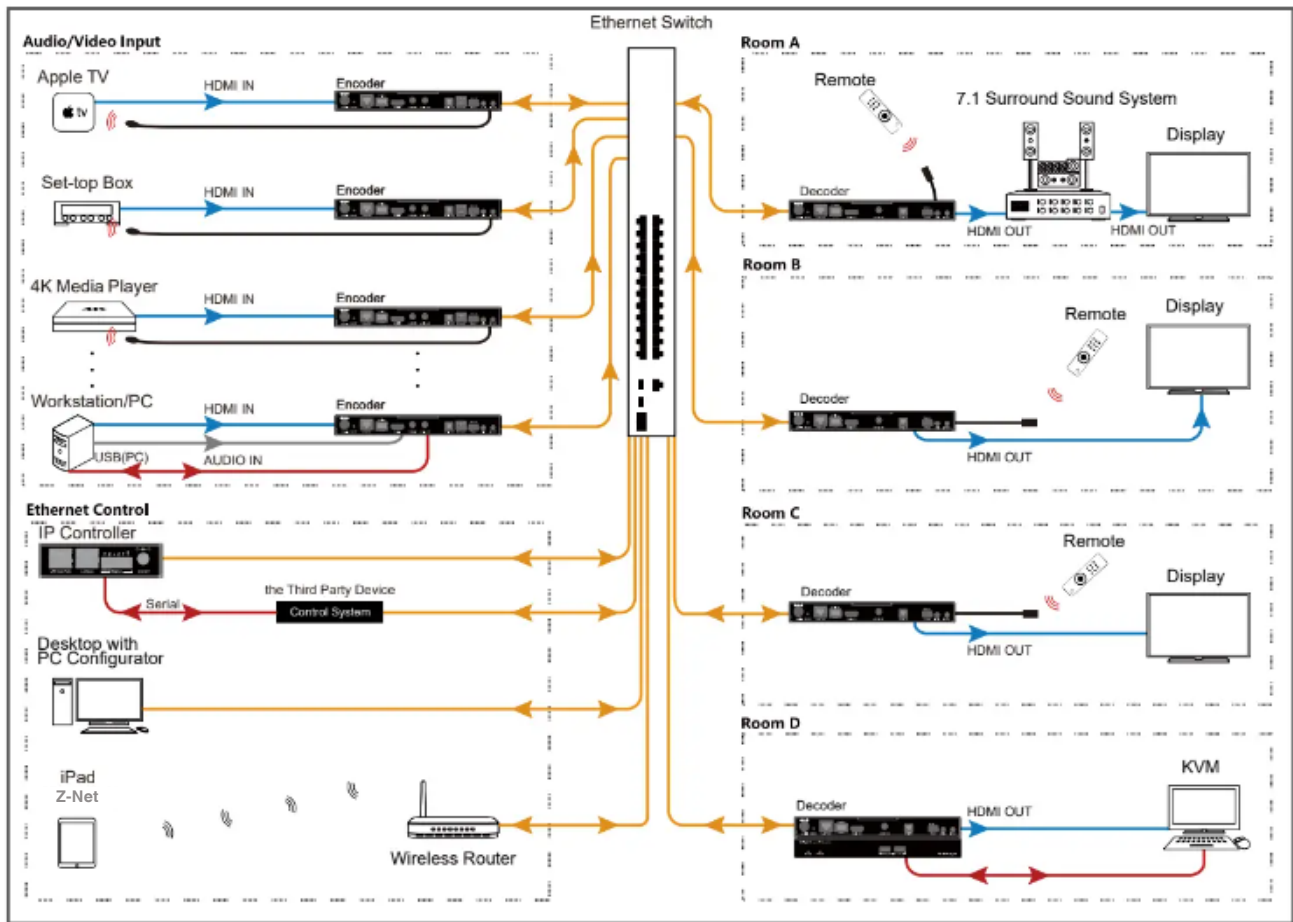

4. Hardware Installation

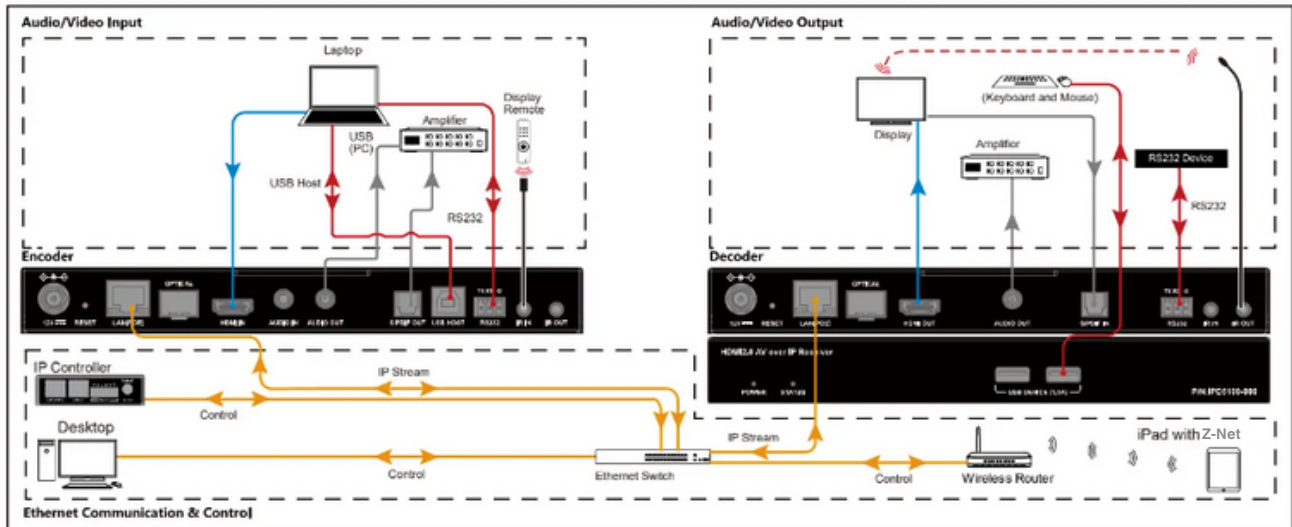

Note:

If the Ethernet switch doesn't support PoE, connect encoders and decoders to their power adapters.

5. Operating the Devices

a. Introduction to Different Operation Tools

The IP400 series products allow you to use PC configurator, Z-Net and IP controller (ZT-IP100C) to manage and control them. This section briefly introduces how to route the video from source to the display using these tools. By default, audio, together with IR, and USB signals are routed as a whole. For more information, see their guides.

The following tables describes how audio, video, and USB signals along with IR are routed using all the different tools.

| Operation Tools | Description |
|-----------------|---|
| PC Configurator | Route audio, video together with IR and USB signals as a whole. |
| Z-Net iPad App | |
| IP Controller | Both of the following routing policies are available. <ul style="list-style-type: none">• Route audio, video together with IR and USB signals as a whole.• Route audio, video together with IR, and USB signals separately via IP controller's API commands. |

Note:

When audio, video together with IR, and USB signals are routed separately via IP controller's API commands, they can be routed as a whole using other operation tools.

b. Performing Fast Switching

The fast video switching function is that when a source change is implemented, the switch occurs very quickly and appears seamless to the human eye with the latency of one second only. However, users shall meet several requirements prior to realizing the fast switching. Otherwise, video switching may take longer (approx. 5-7 seconds), and black out screen would arise.

i. Before You Start

Complete the following requirements before performing last video switching:

1. Verify you have the firmware version of 1.3.x or higher for the decoders and all of which use the same version.
2. Verify that the latest video source to be input **MUST** have the same video timing as current video source, including:
 - Same resolution and refresh rate (e.g. all with 1080p@60Hz).
 - Switching from HDMI to DVI timing is also available. (DVI to HDMI will cause black screen issues.)
 - Same scanning mode (interlace/progressive).
 - Same HDMI info frame (e.g. switch between 2D and 2D, or 3D and 3D).
 - Same color space.
 - Same color depth.
 - Decoders that are set for forced scaler output are exempt from the requirement:
 - set astparam “v_output_timing_convert” as expected output. For more information, refer to the separate document “IP400 Console API”.
3. Verify that the same HDCP mode is applied on all sources. Switching between HDCP and non-HDCP will cause black screen issues.
 - a. Decoders that are set for forced HDCP output are exempt from the requirement: set astparam ‘hdcp_always_on’ and ‘hdcp_always_on_22’ as expected output. For more information, refer to the separate document “IP400 Console API”
4. Verify that all sources are with support of SDR instead of HDR; switching between SDR and HDR (including HDR10 / HDR10+ / Dolby Vision) will result in black screen.
 - a. (e.g. SDR > SDR: ✓ (Fast Switching))
 - b. (e.g. SDR > HDR10 / HDR10+ / Dolby Vision: × (black screen occurs)

The following table lists different cases in which whether black screen encounters or not.

| Change Case | | Configuration | Pass through | Force Timing (+)(#) | Force Timing (+) (w initial pixel format) | Pass through (Strict Mode) | Force HDCP | Force Timing (+)(#) & Force HDCP |
|--------------------------|---------------------------|--------------------------|--------------|---------------------|---|----------------------------|------------|----------------------------------|
| HDCP Change | | | • | • | • | • | ○ (1) | ○ (1) |
| Resolution Change | | | • | ○ | ○ | • | • | ○ |
| Refresh Rate Change (*1) | | | • | ○ | ○ | • | • | ○ |
| DVI-to-HDMI | | | • | ○ | ○ | • | • | ○ |
| Color Depth Change | | | • | ○ (2) | ○ (2) | • | ○ (2) | ○ (2) |
| HDR Change | from/to HDR10 (*2) | | • | • | • | • | • | • |
| | from/to HDR10+ (*3) | | • | • | • | • | • | • |
| | from/to Dolby Vision (*3) | | • | • | • | • | • | • |
| AVI-IF Change | Extended Colorimetry (EC) | from/to BT.2020 | • | ○ (3) | • | • | • | ○ (3) |
| | Colorimetry | from/to EC | • | ○ (3) | • | • | • | ○ (3) |
| | Pixel Encoding | both EC are BT.2020 (*4) | • | ○ (3) | • | • | • | ○ (3) |

| Change Case | | Configuration | Pass through | Force Timing (†)(#) | Force Timing (†) (w initial pixel format) | Pass through (Strict Mode) | Force HDCP | Force Timing (†)(#) & Force HDCP |
|---|--------|----------------|--------------|---------------------|---|----------------------------|------------|----------------------------------|
| | | from/to YUV420 | ● | ○ (3) | ● | ● | ● | ○ (3) |
| | | others | ○ | ○ | ○ | ● | ○ | ○ |
| | others | | ○ | ○ | ○ | ● | ○ | ○ |
| VS-IF Change | | | ○ | ○ | ○ | ○ | ○ | ○ |
| DRM-IF Change (*5) | | | ○ | ○ | ○ | ○ | ○ | ○ |
| Note | | | | | | | | |
| Pixel Encoding: RGB/YUV444/YUV422/YUV420 Colorimetry: BT709/BT.601 ● - Do re-configure whole Video Output, black screen occurs. ○ - Do not re-configure whole Video Output, black screen doesn't occur. *1 - NTSC/non-NTSC case (i.e., 59.94/60Hz, 29.97/30Hz ...etc.) is not included. *2 - Need to re-configure whole Video Output to avoid incorrect brightness issue. *3 - Need to re-configure whole Video Output to avoid video sink (TV) compatibility issue. *4 - Need to re-configure whole Video Output to solve incorrect HDR display with specific player. *5 - YouTube HDR switching behavior; a few monitors always display black screen during video change even if that monitor directly connects to the video source. † - video output will keep in the specified video resolution and refresh rate defined in forced-timing configuration when whole Video Output is re-configured. # - default pixel encoding is RGB 8 bits. Can be configured to YUV444/YUV422 by setting astparam, v_output_timing_convert, BIT [29] and BIT [22:21]. Please refer to document "IP5X00 Console API" for details. (1) HDCP level stays in what user defined. (2) Keep the same color depth as what it was set on previous "whole Video Output configuration". (3) Users may see something a little bit different if compared to the output from original source. | | | | | | | | |

6. Configuring Mouse Roaming

IP400 series products support Mouse Roaming. With configuration on the PC configurator, you can move the mouse to the end of the screen to control different computers in a system. They support one set of mouse and keyboard to control up to 16 host computers.

2 x 1 video wall for example.

To configure Mouse Roaming, perform the following:

1. Connect one computer to the **HDMI IN** and **USB Host** ports of each **TX**; and one set of mouse / keyboard to the **USB Device1** ports of one **RX**.

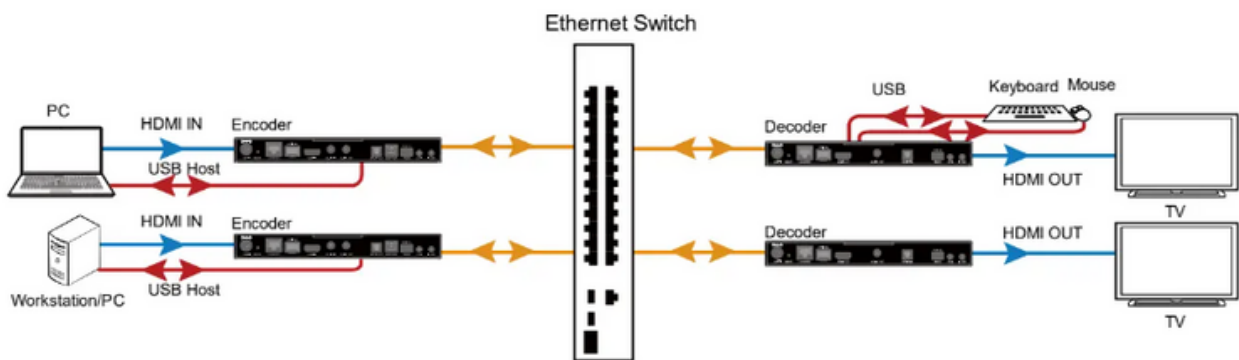

2. Launch the **Z-Net Configuration Tool** on your computer to open its main page. (Ensure your PC, TX and RX are on the same subnet.) Click **Search** to search for online devices.

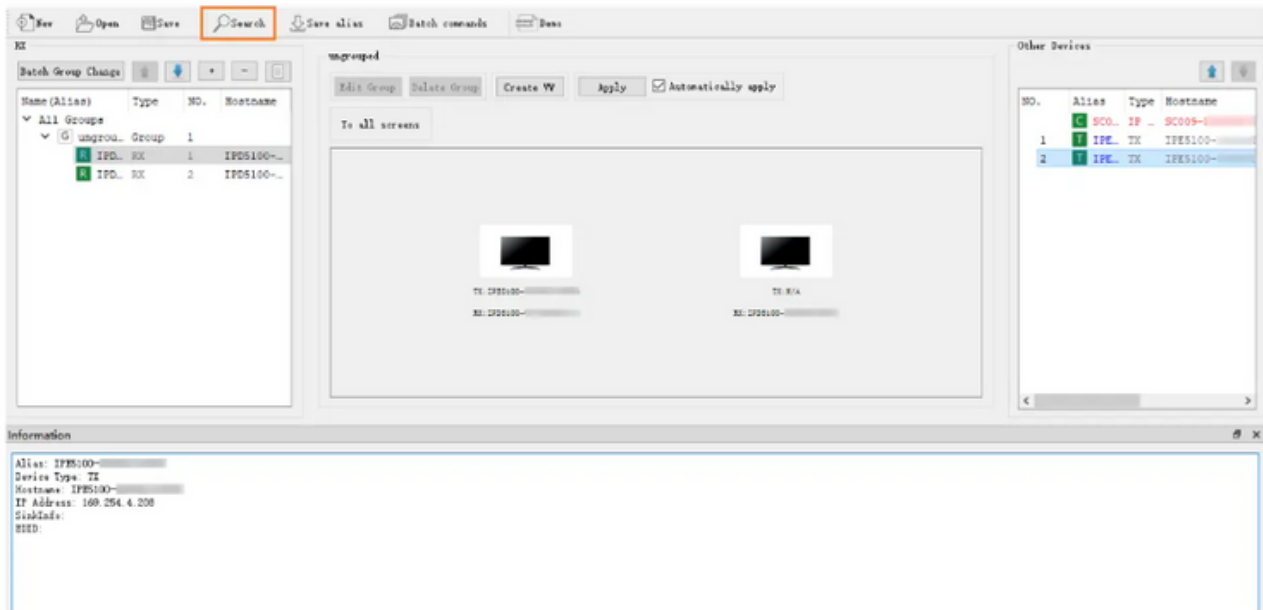

3. Create a video wall.

Click **ungrouped** in the RX list > **Create VW** > Name a video wall (e.g. **VW**) and specify rows and columns > **OK**.

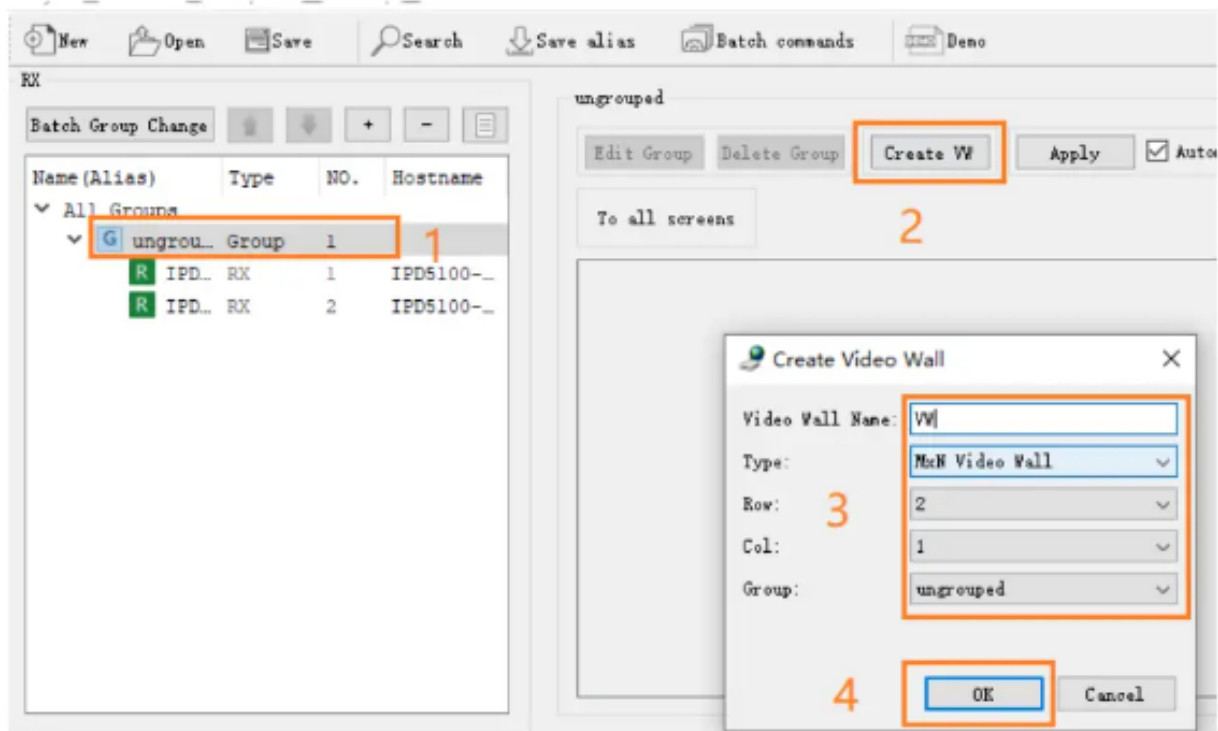

4. Create a layout for the video wall.

Click **VW** in the RX list > Create **Layout/Scene** in the working area > name this layout **layout1** and choose **Mouse Roaming** > **OK**.

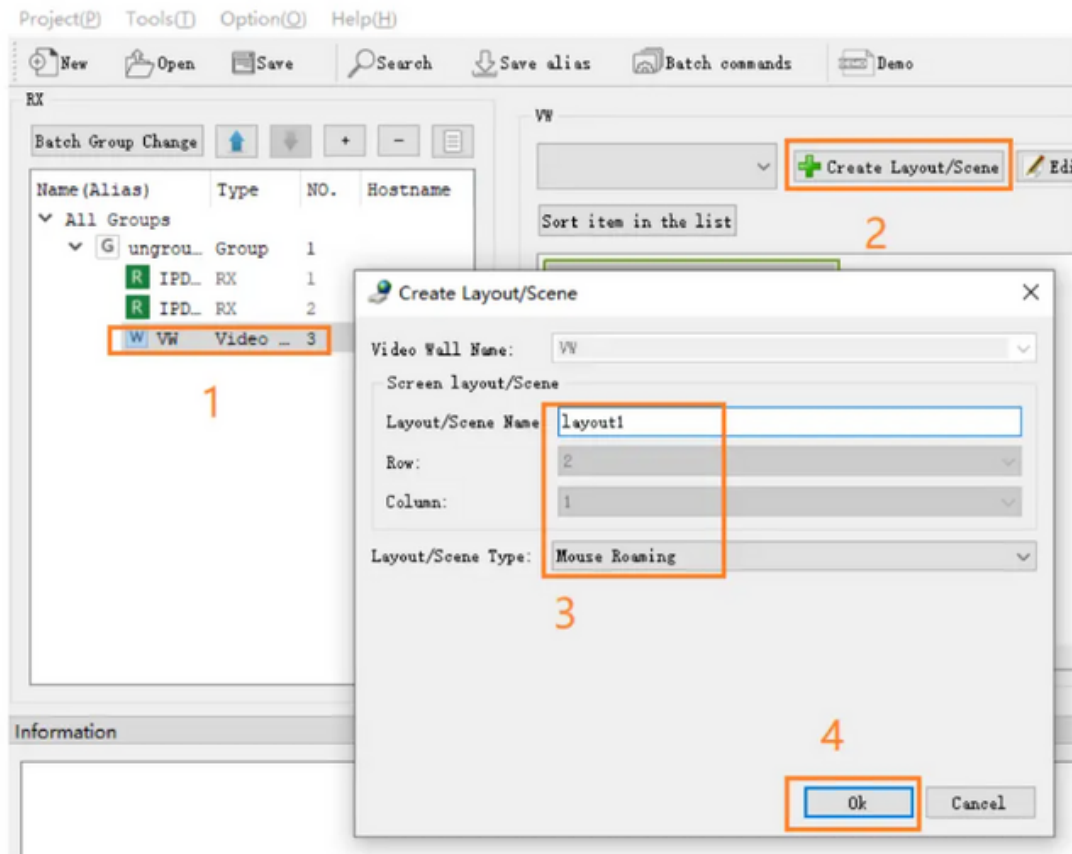

5. Configure **RX** and **TX** for **layout1**.

Drag RXs from the RX list and TXs from Other Devices area to display tiles in the working area.

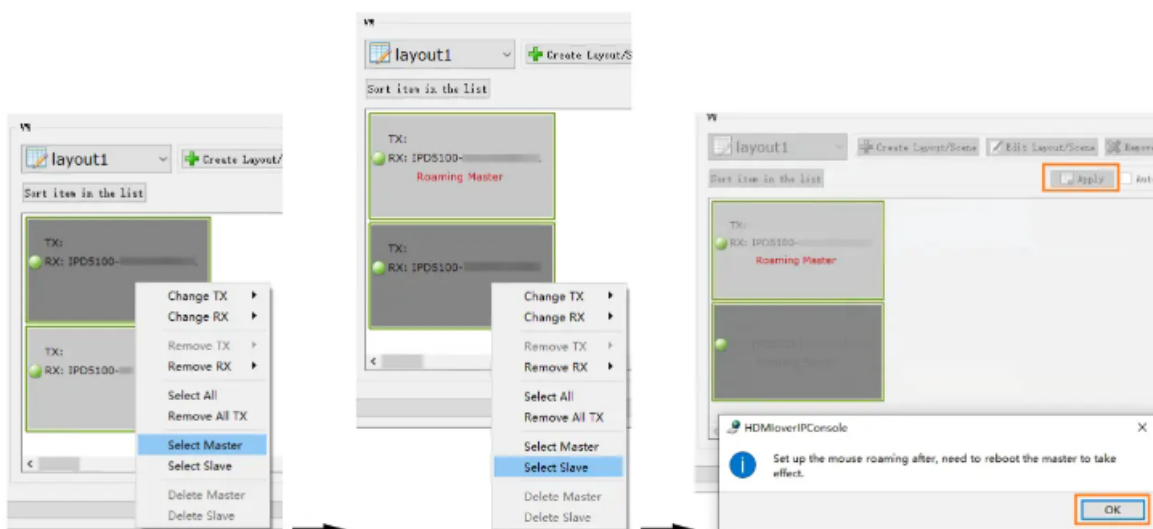

6. Configure **Master** and **Slave**

Right click the RX to which the mouse and keyboard are connected and choose **Select Master** > right click the other RX and choose **Select Slave** > Click **Apply** > **OK**

NOTE: To cancel **Select Master** (or **Select Slave**) setting, right click on the RX and choose **Delete Master** (or **Delete Slave**).

7. Reboot the RX for Mouse Roaming configuration to take effect. Select **Batch Commands > Others > Select RX device > Reboot > Apply**. Please wait for a few seconds for the RX device to reboot.

Now you can use the Master Roaming mouse to control both computers.

7. Configuring before HDR10 / Dolby Vision Signal Input

IP400 series support HDR10 and Dolby Vision only if the device's HDMI Timing Hybrid is set to "Pass-through" mode (default setting).

Before you input a HDR10/Dolby Vision video, ensure the source and all displays support HDR10/Dolby Vision, and follow the steps before to configure the decoder(s) through PC configurator:

1. On the PC configurator, click **Batch Commands** to open Batch Commands window:
 - a. Click **Video** Tab > Choose IP400 devices in the **Devices** list > Click **Pass-Through** from the drop down list in **HDMI Timing Hybrid** region > click **Apply**.

NOTE: The default setting for HDMI Timing Hybrid is **Pass-Through**.

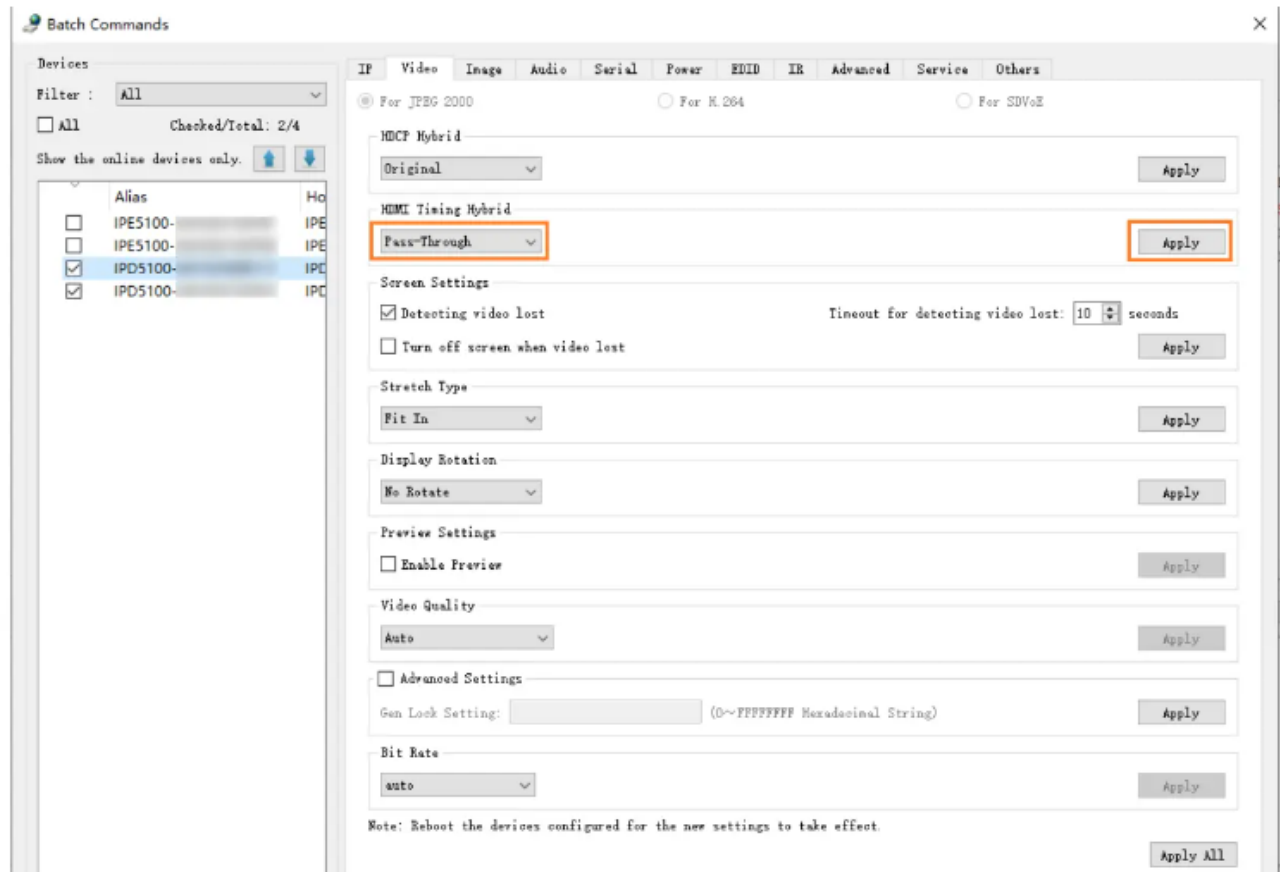

2. Reboot the above devices for the new settings to take effect.
3. Upload the EDID file of HDR10 or Dolby Vision to specific encoder.

Limitations: The video preview's color in Dolby Vision Standard mode may go wrong.

8. Firmware Upgrade

You can use **Z-Net Maintenance Tool** to update the encoders and decoders to their latest versions to obtain new features. For more information, see the user guide of **Z-Net Maintenance Tool**.

9. Maintenance

Clean this unit with a soft, dry cloth. Never use alcohol, paint thinner, or benzine to clean.

10. Warranty

If your product does not work properly because of a defect in materials or workmanship, our company (referred to as “the warrantor”) will, for the length of the period indicated as below, “Parts and Labor (5) Years”, which starts with the date of original purchase (“Limited Warranty period”), at its option either (a) repair your product with new or refurbished parts, or (b) replace it with a new or a refurbished product. The decision to repair or replace will be made by the warrantor.

During the “Labor” limited warranty period, there will be no charge for labor. During the “Parts” warranty period, there will be no charge for parts. You must mail-in your product during the warranty period. This Limited Warranty is extended only to the original purchaser and only covers products purchased as new. A purchase receipt or other proof of original purchase date is required for Limited Warranty service.

11. Mail-In Service

When shipping the unit, carefully pack and send it prepaid, adequately insured, and preferably in the original carton. Include a letter detailing the complaint and provide a daytime phone and/or email address where you can be reached phone and/or email address where you can be reached.

12. Limited Warranty Limits and Exclusions

This Limited Warranty ONLY COVERS failures due to defects in material or workmanship, and DOES NOT COVER normal wear and tear or cosmetic damage. The Limited Warranty ALSO DOES NOT COVER damages which occurred in shipment, or failures which are caused by products not supplied by warrantor, or failures which result from accidents, misuse, abuse, neglect, mishandling, misapplication, alteration, faulty installation, set-up adjustments, mis-adjustment of consumer controls, improper maintenance, power line surge, lightning damage, modification, or service by anyone other than a Factory Service center or other Authorized Servicer, or damage that is attributed to acts of God.

THERE ARE NO EXPRESS WARRANTIES EXCEPT AS LISTED UNDER “LIMITED WARRANTY COVERAGE”.

THE WARRANTOR IS NOT LIABLE FOR INCIDENTAL OR CONSEQUENTIAL DAMAGES RESULTING FROM

THE USE OF THIS PRODUCT, OR ARISING OUT OF ANY BREACH OF THIS WARRANTY. (As examples, this

excludes damages for lost time, cost of having someone remove or re-install an installed unit if applicable, travel to and from the service, loss of or damage to media or images, data or other recorded content. The items listed are not exclusive, but are for illustration only.) PARTS AND SERVICE, WHICH ARE NOT COVERED BY THIS LIMITED WARRANTY, ARE YOUR RESPONSIBILITY.



WWW.ZENTY.COM
9807 EMILY LANE
STAFFORD, TX 77477

(844) 200-1945
SUPPORT@ZENTY.COM
SALES@ZENTY.COM